

Operation and Maintenance Manual

Integral Air Cap

BAC70VP



This manual contains important information on warnings and cautions. Read the manual thoroughly before starting to operate the equipment, and follow the instructions.

Always keep the manual handy until such time that the product is no longer being used. If your manual is lost or worn badly, do not hesitate to contact Asahi Sunac Corporation, directly, and ask us to send you a new one.

Introduction

Thank you for buying our product, integral air cap <BAC70VP>.

Before you use the equipment, carefully read this manual and get to know how to use it safely, efficiently and effectively. Please pay particular attention to major specifications, warnings and precautions, including prohibited items. Use the equipment appropriately and with care, following the instructions. We hope that by doing so you will win benefit from use of the product over a long period of time.

The painting equipment in this manual is for industrial use only, calling for a qualified person to operate. Use of the equipment should, therefore, be limited to those who have acquired operation and application skills through an authorized training course.

Should you have any questions with regard to the manual, please give us the “Model Name” and “Serial Number” of your equipment, so that we may be able help you with your questions. You can reach us at any of the addresses, phone numbers and fax numbers shown on the back cover.

Contents

1	For Your Safety	1
2	Entire Structure	2
3	Removal Method	3
4	Maintenance Log	7
5	Warranty	8



Please read and follow all the technical and safety instructions in this manual.

Failure to do so may result in personal injury and/or property damage.

While all the safety precautions in the manual are very important, you should not consider them to be as cure-all. They are nothing but minimum requirements. You are requested to follow the laws and regulations, as well as the rules of your company or factory.

Shown below and in the pages that follow are the basic minimum safety precautions in connection with use of our product.

● **Safety precautions are classified into three categories based on the severity of hazards involved.**

	WARNING	Alerts a hazardous situation which may result in personal injury, along with hazard avoidance measures.
	CAUTION	Alerts a hazardous situation which may result in equipment damage or breakage, along with hazard avoidance measures.
	NOTE	Indicates important methods and practical information.

* Safety precautions classified into the CAUTION category could cause personal injury if not properly followed.

To ensure safety and prevent equipment failure, always observe the safety precautions and follow the hazard avoidance measures in any categories.

WARNING

- As for the handling of the coating machine, observe the descriptions in the manual of the coating machine to be used.
- If you inhale a lot of organic solvent gas around the coating machine, physical disorder such as a nerve paralysis may occur. Provide adequate ventilation before work.
- If you handle the nozzle when you are charged with static electricity, inflammable gas of organic solvent etc. around the coating machine may catch fire due to electrostatic discharge. Before work, completely remove the static electricity in your body by strongly holding a grounding object.

2

Entire Structure

φ70 air cap set

15F1

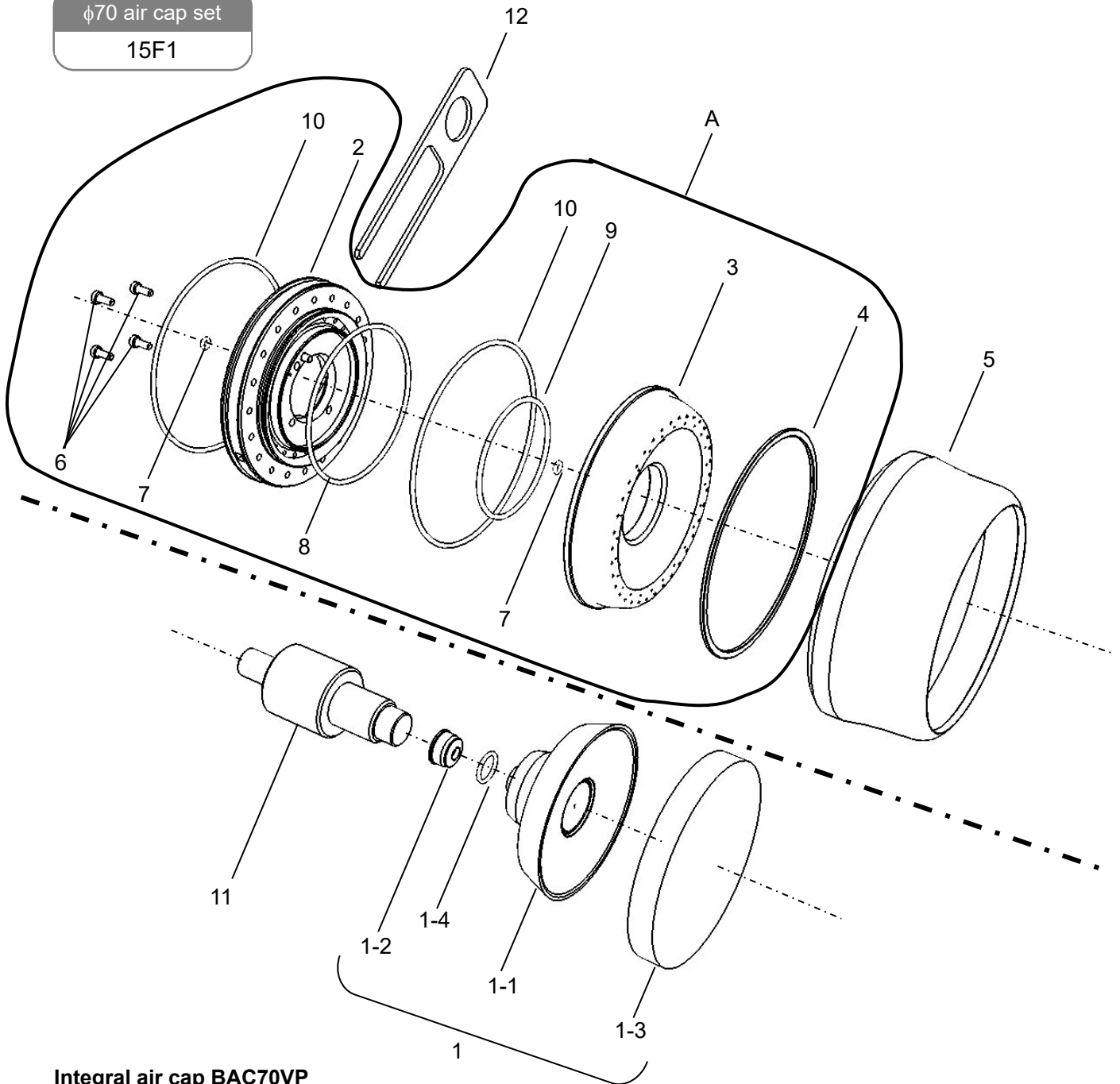

Integral air cap BAC70VP

No.	Parts No.	Part name	Quantity	Remarks
1	15F2	φ70 Bell Cup	1 set	
1-1	15F2-001	Cup	1	
1-2	15F2-102	Inner	1	
1-3	157C-012	Pad	1	
1-4	130-9010	O-ring	1	
2	15F1-002	Baffle	1	
3	15F1-003	Nozzle	1	
4	15F3-004	Ring	1	
5	15F3-005	Cap	1	

No.	Parts No.	Part name	Quantity	Remarks
6	03-70308	Hex. socket screw	4	
7	130-9003	O-ring	2	
8	130-9048	O-ring	1	
9	130-9065	O-ring	1	
10	130-9085	O-ring	2	
11	15F3-111	Cup tool	1	
12	15F3-012	Flat spanner	1	
A	15F5	Baffle nozzle set	1 set	

3

Removal Method

(1) Air cap attachment method



1. Attachment of O-rings to nozzle

Check that three O-rings are attached to the nozzle.

a: O-ring (130-9003)

b: O-ring (130-9065)

c: O-ring (130-9085)

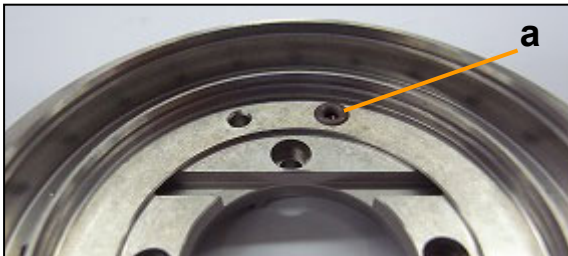

2. Attachment of O-rings to baffle

Check that three O-rings are attached to the baffle.

a: O-ring (130-9003)

b: O-ring (130-9048)

c: O-ring (130-9085)

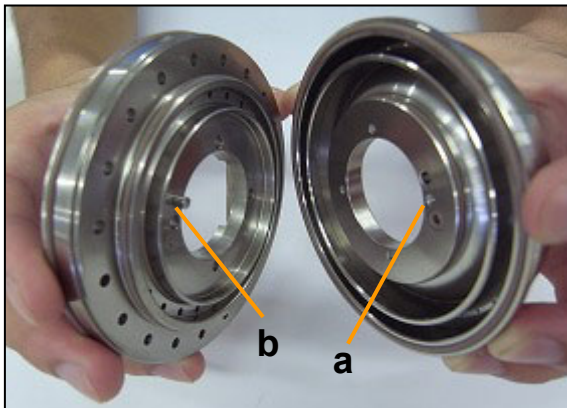

3. Assembly of nozzle and baffle

When assembling the nozzle to the baffle, insert it into the baffle so that the positioning pin will be put into the hole.

a: Positioning hole (nozzle)

b: Positioning pin (baffle)

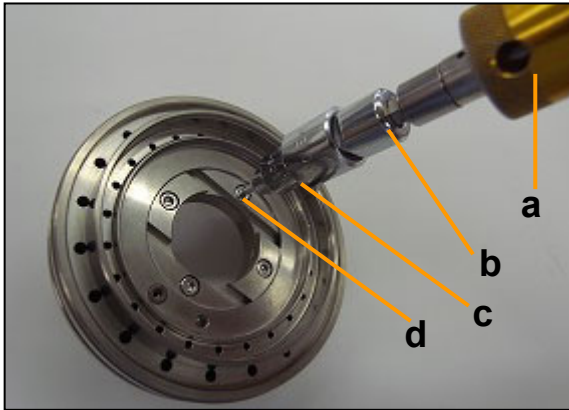

4-1. Fixation of nozzle and baffle

After inserting the nozzle into the baffle, tighten and fix four hex. socket bolts at 150 cN•m using the dedicated tools, the torque driver, socket adaptor and hex. bit.

- a: Torque driver (337-0028)
- b: Hex. bit C (337-0037)
- c: Socket adaptor (337-0033)
- d: Hex. socket bolt (03-70308)

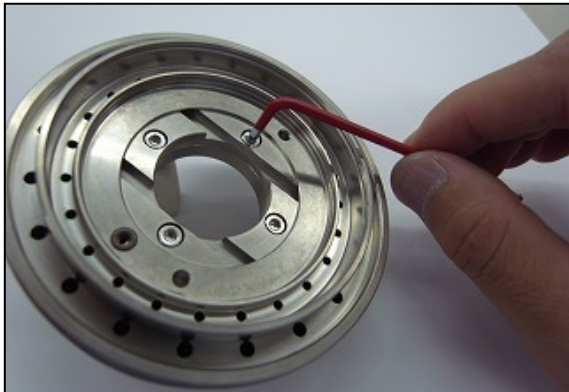

4-2. Removal

Remove the hex. socket bolts with the hex key and draw out the nozzle from the baffle.

- a: Hex key (337-0025)

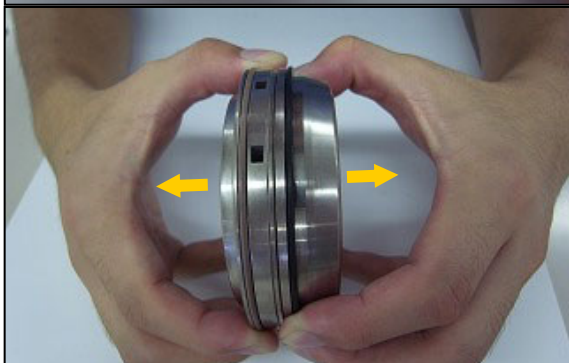

CAUTION

The torque driver is for tightening only.
Do not use it for removing.
Damage may occur.

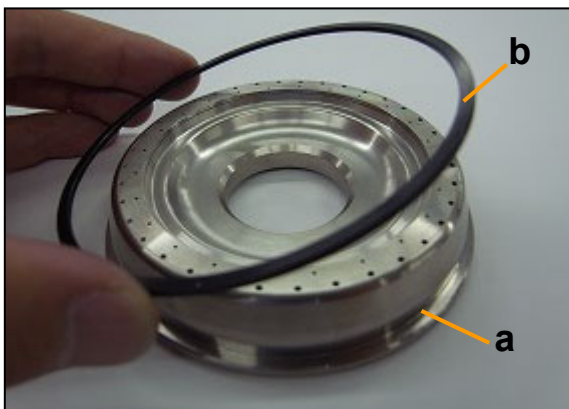

5. Attachment of ring

Attach the ring to the nozzle and baffle set.

- a: Nozzle and baffle set
- b: Ring

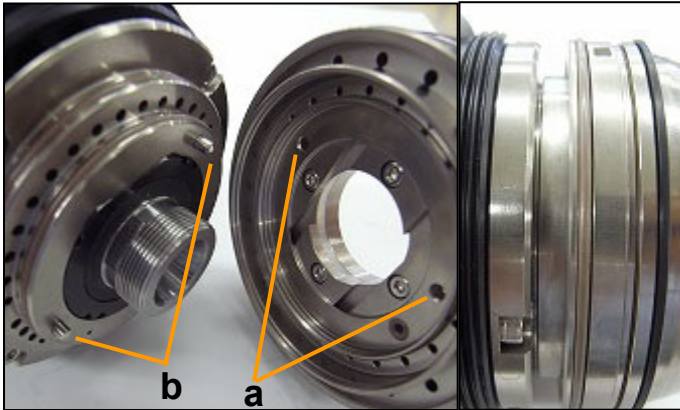

6. Assembly of nozzle and baffle set

Insert the set so that the two positioning pins will fit and push it until the O-ring is covered.

- a: Positioning hole (nozzle and baffle set)
- b: Positioning pin (gun)

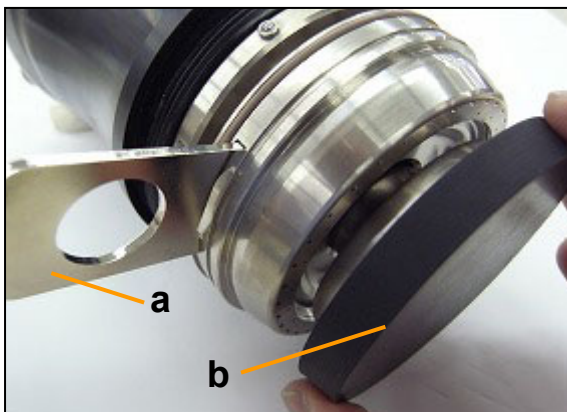

7. Attachment of bell cup

Insert the flat spanner (accessory tool) into the tool hole on the side of the baffle and fix the air spindle shaft.

Screw in the bell cup with the pad.

Then check that there is no paint on the bell cup/air spindle conical section.

- a: Flat spanner (15F3-012)
- b: Pad (157C-012)

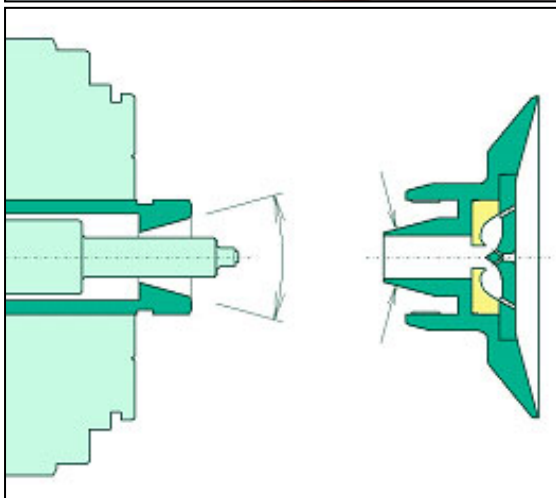

! CAUTION

When the bell cup is attached while paint dirt adheres to the conical section, the rotational balance of air cap is lost and the air spindle is damaged if it is rotated at high-speed by air spindle.

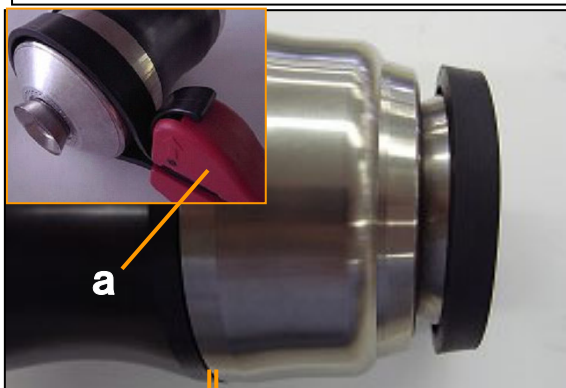

8. Attachment of cap

Remove the flat spanner and screw in the cap. Tighten it so that the clearance between the gun body and cap will be as shown in the left figure. When the pad is removed, the attachment is completed.

If it cannot be removed easily, apply petrolatum to the O-ring and use a belt wrench.

- a: Belt wrench (337-0034)

Approximately 0.5–0.8 mm

(2) Bell cup and inner attachment method

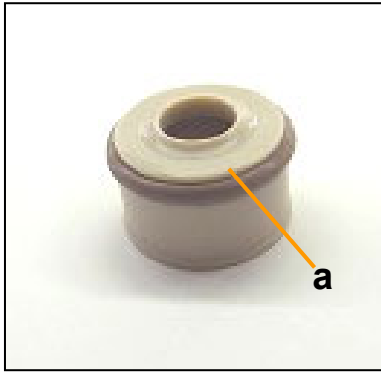

1. Attachment of O-ring to inner

Check that one O-ring is attached to the inner.

a: O-ring (130-9010)



2-1. Attachment of inner

Insert the inner into the cup.

Use the cup tool (accessory tool), pushing in/push side, to push the inner in until it is blocked.

a: Cup tool (15F3-111)

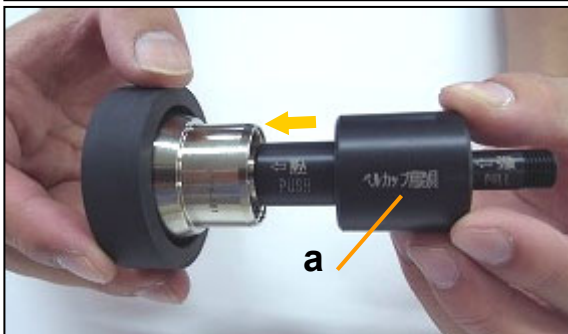

2-2. Removal of inner

Draw it out by screwing the cup tool (accessory tool), drawing out/pull side into the inner. When cleaning the inside of the cup, use a soft brush, etc.

When it is not used, the accessory tool/pad should be kept attached to protect the bell cup.



⚠ CAUTION

The inner may not be removed easily due to paint adhesion. In this case, immerse the bell cup in thinner to let it have lubricity. If you remove it forcibly, the inner may be damaged.

⚠ CAUTION

The bell cup, which was dropped or hit by something, must be replaced with a new one. Rotational balance is lost by deformation of the bell cup, which leads to damage on the air spindle when it is rotated at high-speed by the air spindle.

ASAHI SUNAC CORPORATION (the “Company”) shall provide the original purchaser (the “Purchaser”) with warranty service for a period of 6months from the date of purchase of the product, as follows:

- Should you find defects in design or workmanship with regard to parts, ship them back to the Company, with freight prepaid. The Company shall repair or replace the parts free of charge and reimburse the freight charges, provided that, as a result of an inspection and investigation of the parts conducted by the Company, the defects are deemed to be to attributable to the factors within the Company’s responsibility.
- In the following cases, free after-sales service is not provided.
 1. Failure resulting from an inappropriate method of installing this equipment.
 2. Failure resulting from a use method not conforming to this instruction manual or mishandling.
 3. Failure resulting from insufficient maintenance management of this equipment and incorrect handling such as non-conformance to the procedures specified in this instruction manual.
 4. Failure resulting from unauthorized alteration or structure change of this equipment without the Company’s consent.
 5. Failure due to force majeure such as earthquake, disaster, flood disaster or lightening.
 6. Warranty for consumables worn or deteriorated even in the case where this equipment is used correctly.
 7. Repair after the machine has been used outside Japan, and shipping cost.
 8. In addition to the above, failure due to circumstances beyond our control.
- As for items such as parts purchased by the Company from another manufacturer, the warranty of that manufacturer shall apply.
- As for any parts deemed to be defective, the Company shall not be held liable for any expenses beyond the provision of repair or replacement parts free of charge.
- The Company shall not be held liable for any damage to the Purchaser caused by factors not attributable to the Company, such as misuse of product, etc.

[MEMO]

-
- When a transfer of title of this equipment takes place, please see to it that this Operation and Maintenance Manual is handed over to the new owner.
 - This equipment is manufactured in compliance with the Laws and Regulations of Japan. In the rare eventuality of this equipment being used outside Japan, compliance with the safety standards of the relevant countries is of course mandatory.
-

5th Edition: December 6, 2022



Leading Manufacturer of Coating FA Systems
ASAHI SUNAC CORPORATION
Head office & Factory: 5050 Asahimae-cho, Owariasahi, Aichi 488-8688 Japan

TEL 81-561-52-0717 FAX 81-561-54-8847
e-mail: ctrd01@sunac.co.jp

5th Edition: December 6, 2022