

Operation and Maintenance Manual

Electrostatic Control Panel

BPS1600EX



This manual contains important information on warnings and cautions. Read the manual thoroughly before starting to operate this equipment, and follow the instructions. Always keep the manual handy until such time as the equipment is no longer being used. If your manual is lost or worn badly, do not hesitate to contact our agency which is closest to you, or the Asahi Sunac Corporation, directly, and ask us to send you a new one.

Preface

Thank you very much for choosing our Electrostatic control panel (BPS1600EX).

In order to keep the equipment in the best condition for an extended period, please carefully read this manual before use. Above all, the specifications, warnings and prohibitory or cautionary instructions shown herein shall be fully understood and observed during the use of the equipment.

The equipment covered by this manual is designed for industrial coating work. It shall be used by those who have been duly trained regarding the handling and scope of application and have an understanding of the operating procedure.

If you need further information about this manual, please call any of our branches listed on the back cover by specifying the "model" and "serial No." of your equipment.

1	For Safety and Correct Use	1
2	Overview	5
3	Specifications	6
4	Outside Dimensions	7
5	Names and Functions of Components	8
	5.1 Name of Each Part	8
	5.2 Rating Plate and Warning Labels	10
	5.2.1 About Warning Labels	11
6	Installation Manual	12
	6.1 Cautionary Instructions prior to Installation	12
	6.2 Layout of Control panel and Electrostatic Hand Gun	12
	6.3 How to Install	13
	6.3.1 Control Panel Installation	13
	6.3.2 Utility Connection to Control Panel	13
	6.3.3 Connection to Electrostatic Hand Gun	14
	6.4 System Parameter Setting	15
	6.4.1 BPS Setting on Touch Panel	15
	6.4.2 Recipe Setting on Touch Panel	15
	6.5 Clock Setting	15
7	Operation Manual	16
	7.1 Cautionary Instructions Prior to Operation	16
	7.2 Operation	16
8	Touch Panel Display	17
	8.1 Security Levels	17
	8.2 Numerical Value and Text Input	18
	8.2.1 Numerical Value Input	18
	8.2.2 Text Input	19
	8.3 SLv0 Display	20
	8.4 Additional Display at SLv1	24
	8.5 Additional Display at SLv2	26
	8.6 Additional Display at SLv3	26
9	Various Settings	30
	9.1 Recipe Setting (SLv1 or higher)	30
	9.2 Device Setting (SLv3)	32
	9.2.1 Error Detection Setting	33
	9.3 BPS Setting (SLv3)	34



	9.3.1 Error Detection Setting	35
	9.4 Error Setting	36
	9.4.1 BPS1600 Errors	36
	9.4.2 ASC900 Errors	37
10	Consumable Parts List	39
11	Maintenance Manual	40
	11.1 Cautionary Instructions Prior to Maintenance	40
	11.2 Maintenance Methods	40
	11.2.1 Cleaning Control Panel Outer Sides and Touch Panel	40
	11.2.2 Replacing Protection Sheets	40
	11.2.3 Replacing Air Filters	41
12	BPS1600 Controller Installation	42
13	SD Card Handling	44
	13.1 Data to Save on SD Card	44
	13.2 SD Card Insertion and Ejection	45
	13.2.1 Removing the SD Card	45
	13.2.2 Installing the SD Card	45
14	For Electropneumatic Regulator Faults	46
15	Repair Record	47
16	Revision Record	48
17	Warranty	49

Contents of this instruction manual shall be fully understood and the instructions shown herein shall be strictly observed. Using the machine without following instructions in this manual may lead to **bodily injury or damage to properties**.

The safety measures described herein are the minimum requirements and additional measures may also be required. All requirements provided by laws and legislations as well as rules and guidelines laid by your company or office shall be observed.

The cautionary instructions shown below shall be construed as minimum basic requirements for safety in the use of our product.

● **Cautionary instructions are shown in three levels as defined below.**

 WARNING	Calls the user's attention to a situation that may lead to bodily injury and describes how to avoid that situation.
 CAUTION	Calls the user's attention to a situation that may lead to damage or breakdown to the equipment and describes how to avoid that situation.
NOTE	Gives important or helpful information.

- * Please remember that the situation mentioned under  **CAUTION** may also lead to a serious disaster under certain circumstances. All instructions are important for your safety and prevention of machine disorder and shall be strictly observed.

This manual only describes the BPS1600EX. For the electrostatic gun and coating equipment to be connected with it, see the respective instruction manuals.

WARNING

Adequate conditions of use for the product

The product covered by this instruction manual is a controller specially designed to supply a high-frequency power to the hand-held electrostatic gun contained in the 24VAC high-voltage generator described in the specifications and to control high-voltage charges on the gun. Do not use other than the specified guns.

The product is not explosion-proof. Do not use it in hazardous areas Zone 0 to 2 specified in IEC 60079-10.

If you have any doubt about the intended use of the product or materials used for it, please consult us. Using the product under conditions other than specified above will be considered as abuse unless specially approved by us. In this case, great caution must be exercised to prevent possible accidents.

Danger from abuse

<<General safety requirements>>

- Thoroughly check the supply voltage before use. Applying a voltage other than selected may lead to a failure and/or fire.
- The controller handles high voltages and, therefore, must be properly grounded. Failure to ground it may lead to a failure, electric shock, injury and/or fire. Always ground the protective earth terminal (class A grounding work). Do not fail to tighten screws on the terminal block and attach connectors.
- Do not modify the wiring when it is live.
- **The control panel is not explosion-proof. Do not use it in hazardous areas Zone 0 to 2.**
- Do not pour water over the controller although it complies with protection class IP54. Do not use it outdoors.
- If the controller fails, immediately stop it and turn it off. After checking that it has been discharged, short the charging terminal to the ground.
If the protector or fuse has been tripped, do not turn it on again.
- Do not operate the controller with the door open. Do not touch the charger and hot parts contained in the case. Doing so may lead to a burn, injury and/or electric shock.
- The door, if open, may be unhinged from the case. Do not raise the controller with the door open.
- Usable life of BPS1600EX is 10 years.

WARNING

To prevent fire and explosion

<<Sources of fires>>

The electrostatic coating process uses the electrostatic phenomenon at a higher voltage to positively generate static electricity.

Static electricity is also generated while the paint is running through the pump or hose.

If any part of the coating machine or any metallic object around it is not correctly grounded, electrostatic sparks will be generated. The sparks may ignite volatile components of a solvent, paint mist from the nozzle, suspended particles or another combustible substance to cause a fire or explosion, possibly resulting in serious bodily injury or damage to the equipment.

- Check that the coating machine, all metallic objects around it and the products to be coated have been grounded. If not, a fire or explosion may be caused by electrostatic sparks.
- The spraying place and the vicinity of the coating machine shall be well ventilated.
- Do not bring the high-voltage electrode at the end of the gun or any peripheral device close to a product to be coated or the ground or bring them into contact during the electrostatic coating process. Unknowingly using a faulty gun may generate big sparks. It may also cause damage to the nozzle and electrode.
- When interrupting or finishing the coating process, never fail to turn off the BPS1600EX and, five seconds after that, bring the corona pin at the end of the gun into contact with a grounding wire or grounded metallic object for at least 10 seconds to discharge residual charges.
- Do not plug in or out the coating machine or other electric equipment within a radius of 7 to 8 meters from the spraying place.
- Do not perform the coating work in the vicinity of an open flame, lamp or another source of ignition.
- Never smoke in the spray coating place.
- If you feel shocked even slightly by the static electricity while handling the coating machine, immediately stop the coating work and check each component for grounding. Do not restart the coating work until the cause is determined and corrective action is taken.
- The input power and connecting cables, if damaged, may generate sparks to cause a fire or explosion. Protect the cables from damage.
- Fire extinguishers with a sufficient capacity must be provided at the spray coating place.

<<Grounding>>

To prevent danger from static electricity, completely ground all metallic or conductive objects in the spray coating place (ones in use and booths, hangers, coated products, pumps, coating machines and equipment, fire extinguishers, floor materials, etc. around them). If no adequate ground is provided, perform the grounding work (class A grounding = 10Ω or less) using the methods specified by the Technical Standards for Electric Equipment. The methods for grounding the coating equipment are described below.

WARNING

- **Grounding the working floor**

The working floor shall be constructed from conductive materials and grounded. Spilt paints and stains on the floor, if any, shall be immediately wiped off to maintain the cleanliness.

- **Grounding the paint hose**

Use a completely grounded paint hose.

When using an extended paint hose, check that it has been completely grounded.

- **Grounding the air hose**

Use a completely grounded air hose.

- **Grounding the electrostatic hand gun**

The electrostatic hand gun firmly connected with properly grounded air and paint hoses is considered to be adequately grounded.

- **Completely ground the BPS1600EX.** Connect a grounding wire to the protective earth terminal on the controller for complete grounding (class A or equivalent grounding).

- **Grounding the products to be coated**

The resistance between the products to be coated must not exceed $1\text{k}\Omega$ when the products is a metal and do not exceed $1\text{M}\Omega$ when the resin. Contaminants on hangers and earth clips shall be immediately removed to keep them grounded.

For detail, follow the instructions of the fire station with jurisdiction over the associated region.

- **Grounding the human body**

All persons entering the spray coating place shall wear anti-static clothes with embedded grounding wires and anti-static shoes with clean soles (conductive shoes with a resistance about $10\text{M}\Omega$) so that their bodies will not be charged with static electricity. When performing the electrostatic coating work, hold the gun grip with your bare hand. If it is inevitable to wear gloves, punch a hole at the palm of each glove to bring part of your palm into direct contact with the gun grip or use conductive gloves.

- **Grounding the paint container**

Do not use any paint container other than lidded metallic ones. Provide an exclusive paint port and put the container on a grounded floor or table to completely ground the paint container body. If it is impractical to ground it through a floor or table, connect an exclusive grounding wire to the paint container to completely ground it. In addition, the coating work must be performed with the paint container lid closed.

- **Grounding the cleaning solvent container**

Dripping or spouting cleaning solvent may generate static electricity.

If a metallic container not adequately grounded is used for collecting cleaning solvent, it will be charged with much static electricity to pose a possibility of danger. Use a metallic container put on a grounded floor or table to completely ground the container body. Never put it on a non-conductive material such as corrugated cardboard.

If it is impractical to ground it through a floor or table, connect an exclusive grounding wire to the solvent container to completely ground it.

When cleaning a paint pump or reducing the pressure, firmly hold the hose mouthpiece at the bottom of the gun extension onto the edge of a grounded solvent container and then pull the trigger.

2

Overview

This System is a control panel designed to supply electric power and air to a manual electrostatic spray gun with a built-in high voltage generator of 24VAC transmission power and to control high voltage charging and air supply.

It can control 5 or 10 sets of spray guns at maximum. Operation status of the System and motion status of the guns are indicated on the touch panel screen of the control panel.

High voltage is generated only on the Gun triggered first. There are two models of the Control Panels, for 5 Guns specifications and for 10 Guns specifications.

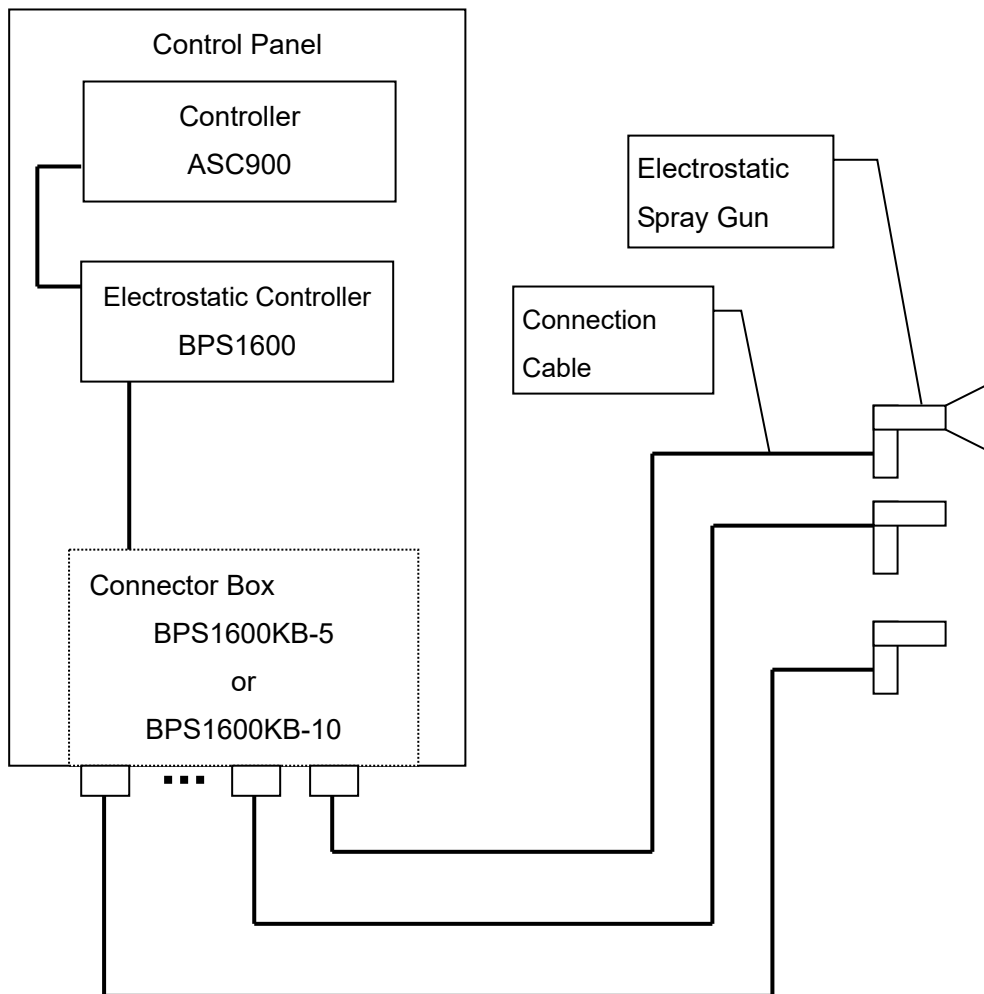

3

Specifications

3.1 Control Panel

Item \ Model	BPS1600EX-5	BPS1600EX-10
No.s of Guns to be used	5 at maximum	10 at maximum
Corresponding Gun	For solvent borne paint:HB5000(-60kV), HB-X3(-30kV) For water borne paint:HB6000(-30kV)	
Storing Conditions	Ambient temperature -10 to 50°C Humidity 10 to 90% (no condensation allowed)	
Conditions of use	Ambient temperature 0 to 40°C Humidity 20 to 85% (no condensation allowed) Altitude : 2000m or less No corrosive gas, dust, vapor, water drops and direct rays of the sun are allowed.	
Protection class	IP54	
Overvoltage category	II	
Mains transient voltage	2500 V	
Pollution degree	2	
Input power	100Va.c. ±10% Power transformer TR 200/220/240 Va.c. * The voltage specification is marked on the rating plate.	
Input frequency	50/60Hz	
Consumption current	2.0 - 1.0A	
Air to be supplied	Air Press. 0.5~0.8MPa Air Flow 400NL/min * Dry air is absolutely required.	
Weight	40kg * Except Stand	44kg * Except Stand
Dimensions(mm)	W600 x D350 x H500 * Except Stand	

3.2 Spray Pattern Controller

Item \ Model	ASC900
Name	Spray Pattern Controller
Part No.	E-020020
Conditions of use	Ambient temperature -10 to 50°C Humidity 10 to 90% (no condensation allowed)
Conditions of use	Ambient temperature 0 to 40°C Humidity 20 to 85% (no condensation allowed) Altitude : 2000m or less No corrosive gas, dust, vapor, water drops and direct rays of the sun are allowed.
Input power	100 VAC to 240VAC ± 10%
Input frequency	50/60Hz
Consumption current	0.3 - 0.2A
Weight	3.0kg

Prepare a SD card (*①) and insert to the touch panel to edit/save production results and graph data or to create backup of recipe setting, device setting, BPS setting or counter values.

*① Supported SD card: FAT16-formatted SD card up to 2GB.

FAT32-formatted SDH card up to 32GB.

4

Outside Dimensions

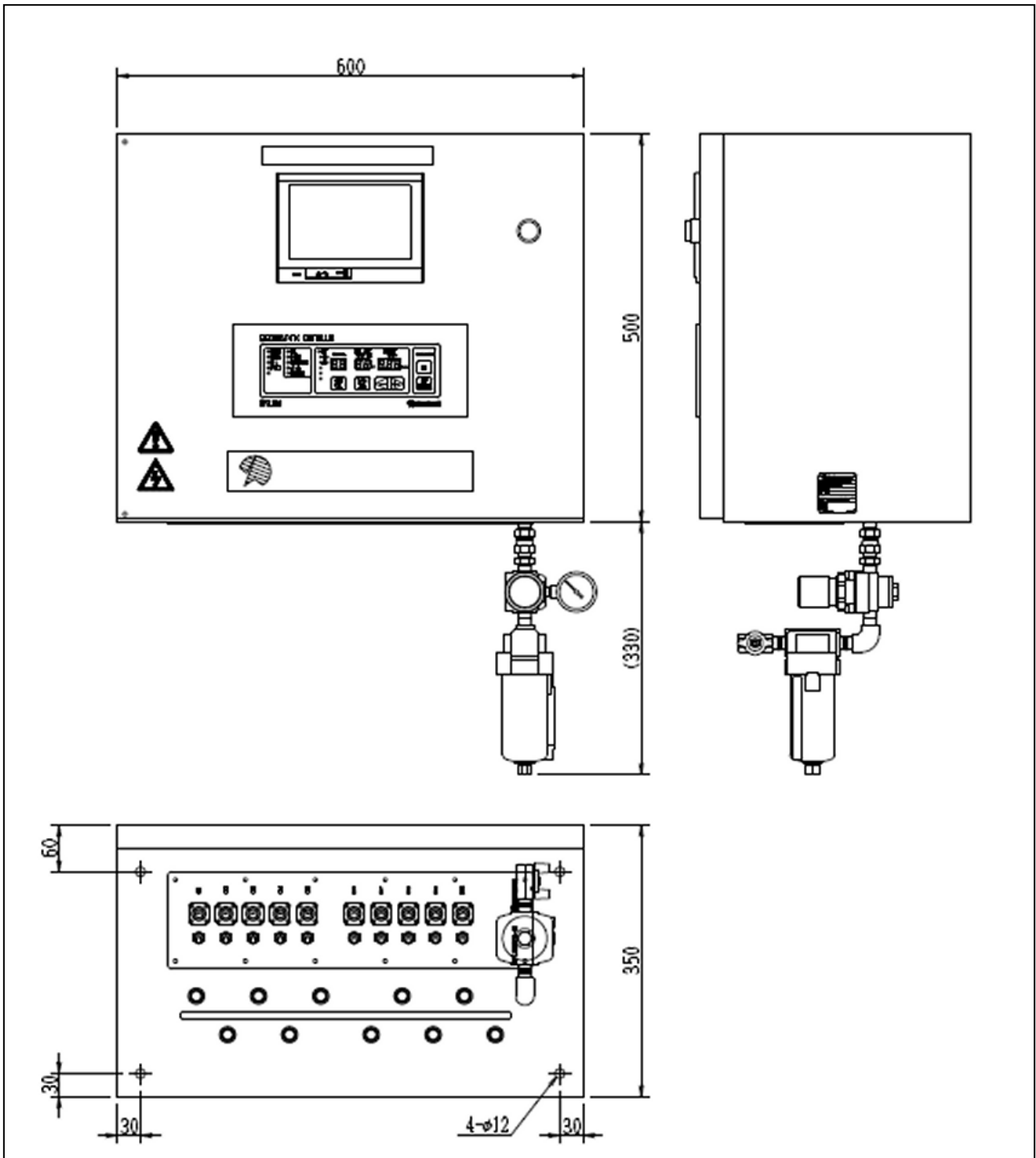

This figure is for the 10 Guns specification.

The numbers of connector boxes and air outlets at the bottom side are different for the 5 Guns specification.

5

Names and Functions of Components

5.1 Name of each Part

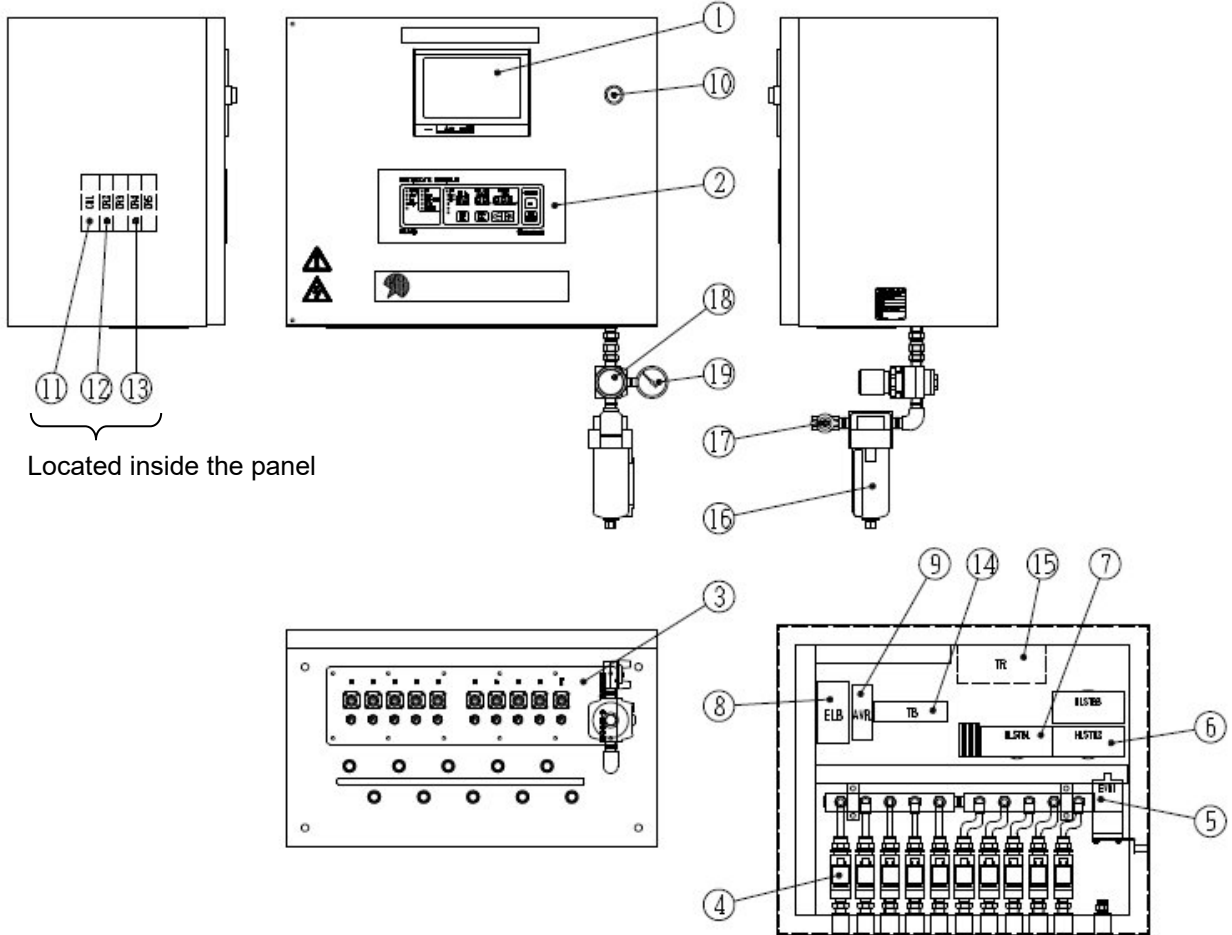

This figure is for the 10 Guns specification.

Connector box, the numbers of, air outlets, digital flow switches, and HL A/D8ch terminal blocks at the bottom side are different for the 5 Guns specification.

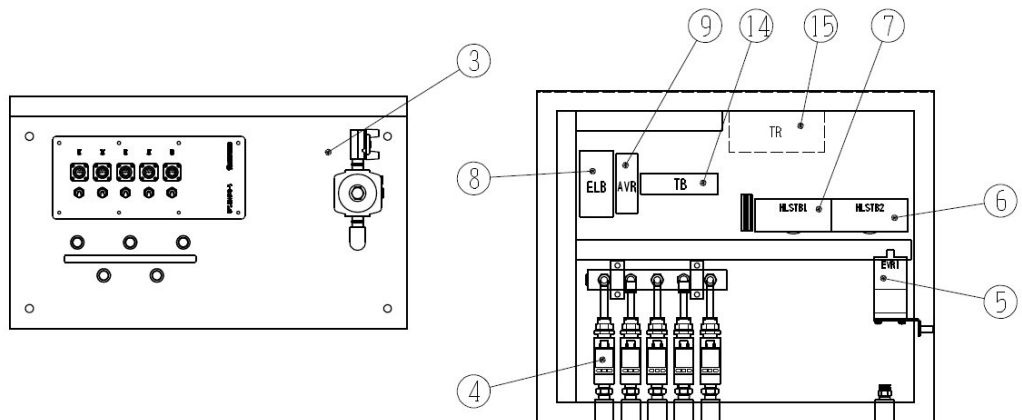

Ref.	Part No.	Symbol	Name	Remarks
1	E-020020		Spray Pattern Controller	ASC900
2	445-0114		Electrostatic Controller	BPS1600
3	445-0115		Connector Box	BPS1600KB-5 * for 5 guns
3'	445-0116		Connector Box	BPS1600KB-10 * for 10 guns
4	375-0008	FS1-10	Digital Flow Switch	PFMB7501-04-C-M * FS1-5 (5 units) for 5 guns
5	301-0079	EVR1	E/P Regulator	ITV2050-013CS-X7
6	471-0014	HLSTB 2-3	HL A/D8ch Terminal Block	R7HL-SVF8NL-R/H * HLSTB2 (1 unit) for 5 guns
7	471-0008	HLSTB1	HL I/O Terminal Block	R7HL-DAC16A-R/H
8	414-0025	ELB1	Circuit Breaker	NV30-FAU 2P 5A 30mA
9	447-0021	AVR1	Switching Power Supply	S8VS-06024
10	E0P2010240401	BZ	Buzzer	DR22B8-EB
11	430-0006	CR1	Relay	MY4N DC24V
12	430-0037	CR2-3	Relay	MY2N DC24V
13	430-0028	CR4-5	Relay	MY2N AC100V
14	410-0047	TB	Terminal Block	CTL-15S-9P
15	442-0026	TR	Power Transformer	KBSW-EN0300-P4-S1-CE * 200/220/240Va.c.
16	303-0027		Air Filter	AF40-03D-2-A
17	325-0058		Ball Cock	BBS-322-10RC
18	301-0036		Air Regulator	AR30K-03H-B-X2140
19	305-0003		Pressure Gauge	PA50A-N62H-R2

Please see the BPS1600 instruction manual for the electrostatic controller and the connector boxes.

Note: The controller shape and specifications may be changed without notice to reflect improvements, etc.

5.2 Rating Plate and Warning Labels

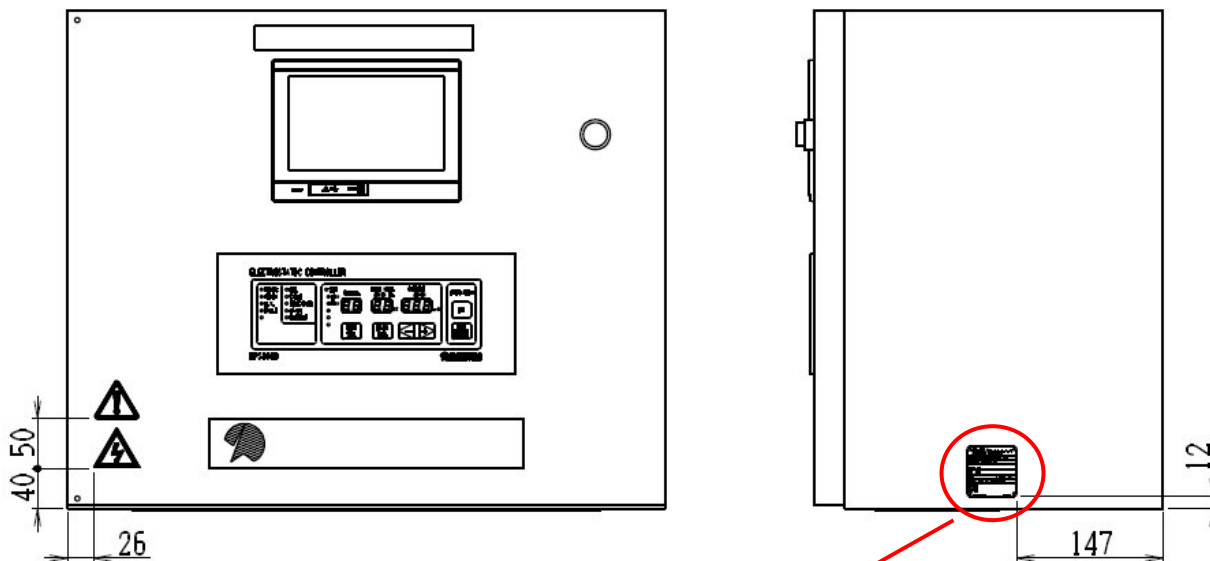

Rating Plate

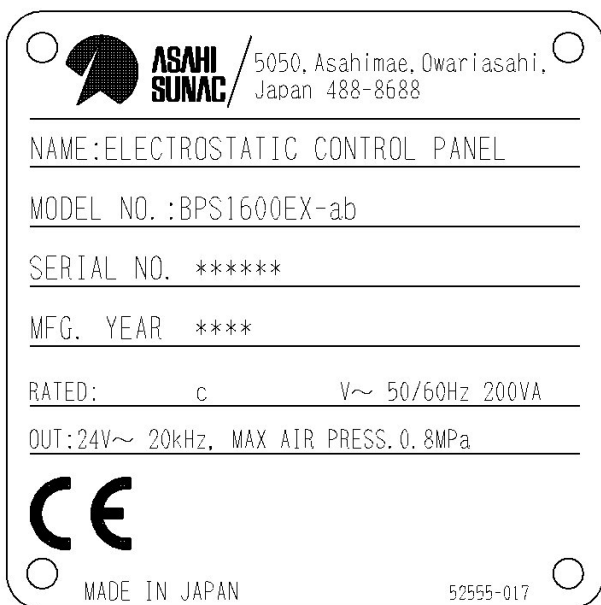

Remarks on Model No.

a	No. of guns to connect	5: Up to 5 guns (for BPS1600KB-5) 10: Up to 10 guns (for BPS1600KB-10)
b	Power transformer	No: Not available; TR: Available

Remarks on Ser.No.

Manufacture year: 5th and 6th digits (Last two digits of the year of the Western calendar)

Manufacture month: 4th digit (X for October, Y for November, and Z for December)

The other 3 digits indicate a serial number (from 001).

Remarks on RATED



c	Voltage specification	100: 100V; 200: 200V; 220: 220V; and 240: 240V
---	-----------------------	--

5.2.1 About Warning Labels

On the System, warning labels are attached near sections where there are risks leading to serious bodily injury accidents.

WARNING

**The contents of the warning labels shall be strictly observed.
Keep the warning labels clean so that they are clear to read. Never attempt to remove them.**

Warning label	Indication area and description
	<p>⊙ Control panel front</p> <p>Be sure to read the instruction manual well before starting the installation, operation, or maintenance of the System. See “6. Installation Manual” for installation and “7. Operation Manual” for operations. Maintenance should be practiced by those who have received respective training in accordance with the contents of “10. Maintenance Manual”.</p>
	<p>⊙ Control panel front</p> <p>⊙ Electronic components inside the control panel Circuit Breaker (ELB1) Switching Power Supply (AVR1) Terminal Block (TB) Relay (CR4-5)</p> <p>The charging unit is located inside the control panel. Contacting the parts with power on may lead to electric shock. Do not operate with the control panel door open. Be sure to shut off the external power supply in all phases before wiring. Failure to do so may lead to electric shock, product damage, and/or malfunction. The circuit breaker, switching power supply, and terminal block cover are detachable. Be sure to place back the cover where it initially was if the cover was removed for wiring or other works. Be sure to turn off the circuit breaker before starting inspection or maintenance on the System.</p>

6.1 Cautions to be taken before Installation

The Control Panel and Switch Box should be installed by well trained person(s) according to instructions described in this Installation Manual. Optional equipment should be installed according to instructions provided for each of such equipment. It separates, and please do not receive, and wire the groundline, the power cable, and the shielded cable for the influence of the noise with other power cables (inverter and servo, etc.) and the signal lines so as not to give it.

6.2 Layout of Control Panel and Hand Gun

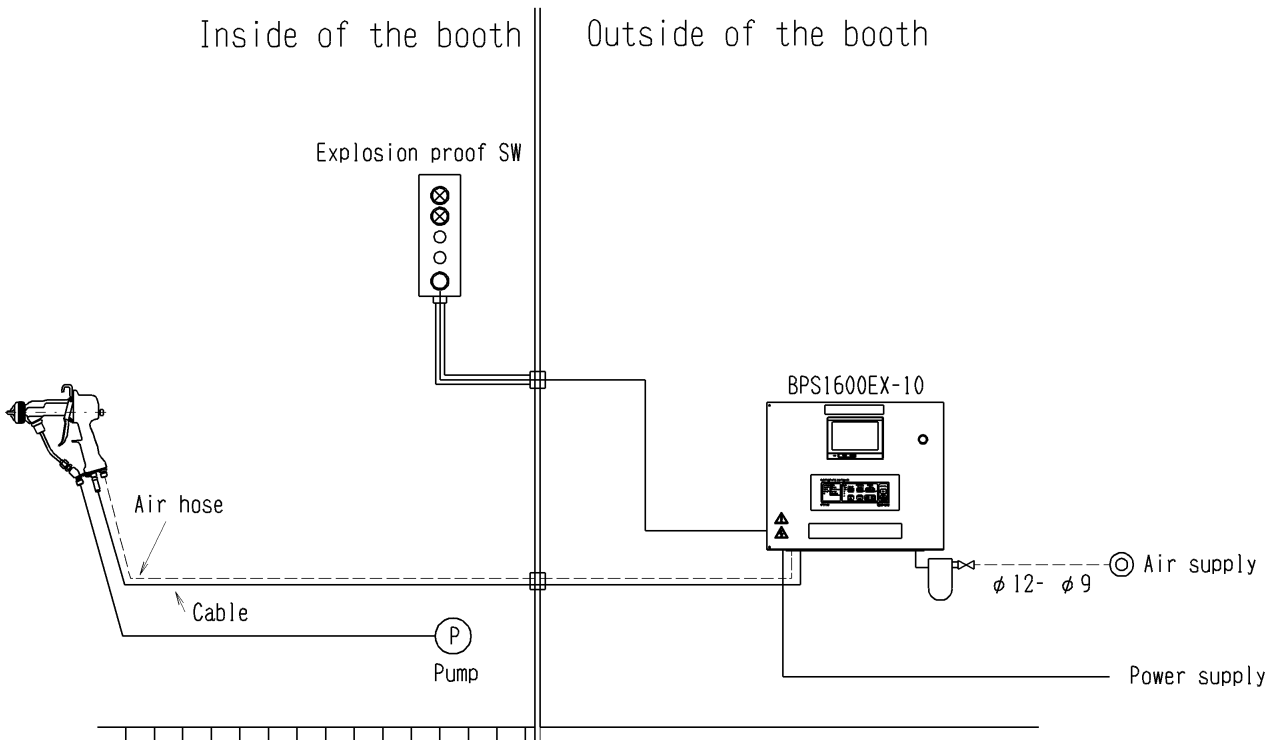

6.3 How to Install

6.3.1 Control Panel Installation

The control panel should be placed on a cart or grabbed on both sides of the panel by several people when it is carried.

If a stand is used, the control panel should be installed on a flat area.

WARNING

Risk of falling

Stabilize with anchors or bolts to prevent from falling (M10, 4 locations).

WARNING

Install the control panel outside the coating booth and keep it at least 1.5m away from the booth opening or outlet/inlet.

6.3.2 Utility Connection to Control Panel

(1) Grounding

Apply class A grounding work to an earth terminal of the control panel.

Use green or yellow electric wires that are equivalent to UL1015 as grounding wire.

Connect to bus bar.

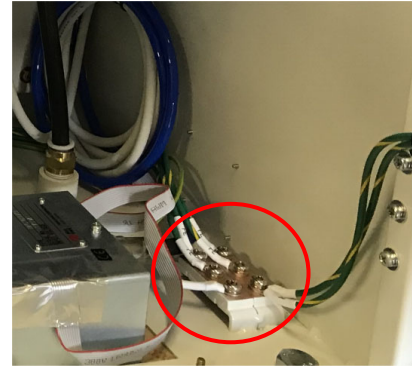

WARNING

Failure to ground may lead to electric shock, fire or explosion.

(2) Primary power source wiring

① Check the rating plate for the voltage specification.

② To lead in a power cable, open a hole on the bottom or the left side of the control panel and use cable glands or others to ensure the protection level IP-54 or higher. Firmly fasten cable glands to avoid loosening.

[Bottom]

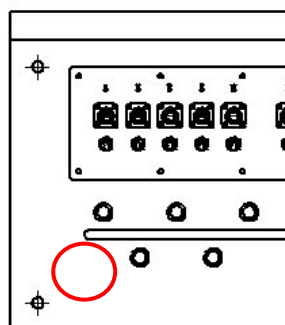

[Left side]

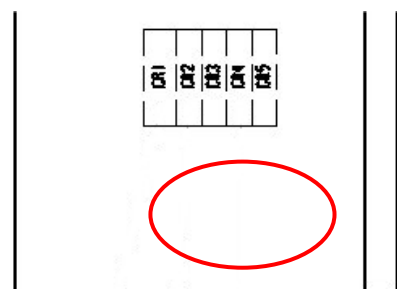

WARNING

Incorrect power input may lead to a failure and/or fire.

- ③ Connect a power line to the IN side of the circuit breaker.
(Rated current: 5A; Rated current sensitivity: 30mA)

Use a cable that is 1.25mm² or more and equivalent to VCT as power cable.

Be sure to turn off any external breaker before connection to prevent electric shock.

Turn on the breaker after all of the devices are connected.

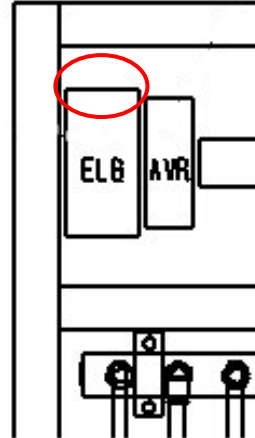

There is no power supply breaker on the panel side of the control panel.

Please install an EN60947-1/EN60947-3 certified breaker at a position easily accessible by the user for operation. The power supply breaker must not be incorporated in a main power cord, and the protective earth conductor must not be shut off.

WARNING

Risk of electric shock

- (3) Primary air piping

Connect the ball cock and the air source at the bottom of the control panel with an air tube of $\Phi 12.9$ or more.

Be sure to supply dry air.

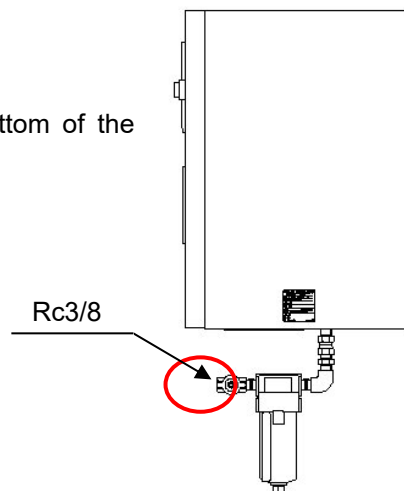

6.3.3 Connection to Electrostatic Hand Gun

- (1) On the electrostatic hand gun side

See the instruction manual of the electrostatic hand gun for connection of cables, air hoses, and coating hoses.

The “cautionary instructions for connection cable bundles and handling” in particular shall be observed.

- (2) On the control panel side

Prepare a set of cables and air hoses to be connected to one electrostatic hand gun and start connecting to the connectors and the air outlets at the bottom of the control panel from GUN1.

Check that the corresponding snap switches are turned on.

If the snap switch is off, electrostatic coating cannot be conducted.

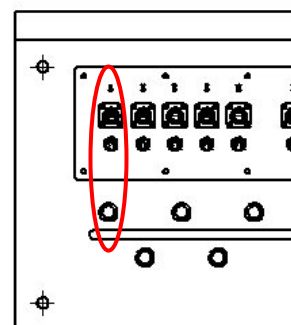

6.4 System Parameter Setting

Discharge amounts and pattern width of the electrostatic hand gun shall be adjusted in accordance with the instruction manual of the electrostatic hand gun.

6.4.1 BPS Setting on Touch Panel

- ① The number of the guns needs to be adjusted based on the control panel specification as follows.
See [9.3 BPS Setting (SLv3 or higher)].

Model	No. of guns
BPS1600EX-5	5
BPS1600EX-10	10

- ② In order to detect damage to the charge electrode, disconnection of the connection cable (feedback current cable) and other failure, it is needed to enable Return Current Error.
When paint of a higher electrical resistance is used with Return Current Error enabled, an error may be detected depending on the setting voltage.
BPS Setting No.27 0→2

6.4.2 Recipe Setting on Touch Panel

- ① According to types of the electrostatic hand guns to connect to, the gun type and voltage for the recipe setting need to be adjusted as follows: See [8.1 Security Levels], [8.2 Numerical Value and Text Input], [8.4 Additional Display at SLv1], and [9.1 Recipe Setting (SLv1 or higher)].

Electrostatic hand gun	Gun type	Voltage [kV]
HB5000	60	10 to 60
HB2020 (previous model)		
HB3020 (previous model)		
HB6000	30	5 to 30
HB-X3		
HB2010 (previous model)	40	6 to 40
HB3010 (previous model)		

- ② Set up the air pressure [MPa] of the recipe setting.
- ③ Set up the standard air flow rate on the standard value renewal page to detect a variation from the default air flow rate as air flow rate over or air flow rate short.
See [8.1 Security Levels], [8.2 Numerical Value and Text Input], and [8.5 Additional Display at SLv2].

6.5 Clock Setting

The clock can be set on the date & time adjustment page if accurate time needs to be shown for production results and alarm history.

See [8.4 Additional Display at SLv1].

7.1 Cautionary Instructions Prior to Operation

This Operation Manual is intended for operators to use.

Before starting operation, please make sure that the installation is properly completed in accordance with the Installation Manual.

7.2 Operation

- ① Before supplying power to the control panel, check that control panel door is closed.



WARNING

Risk of electric shock

- ② Supply power and air to the control panel. (Power supply breaker: ON; Ball cock: Open)
- ③ Power will be supplied to the spray pattern controller ASC900 and the electrostatic controller BPS1600. The power lamp "POWER" of BPS1600 lights up and the program version No. is indicated on the digital ampere meter for approx. 3 sec. (Example: 5.00)
The monitor page (main page) appears on the touch panel of ASC900 if it is correctly wired.
- ④ If the switch box is located in the booth, press the ON button switch of the switch box. The POWER ON lamp of the switch box and the operation lamp "READY" of BPS1600 light up.
If there is no switch box, press the operation switch "ON" button of BPS1600.
- ⑤ Pull the trigger of the electrostatic gun to start electrostatic coating. The H.V. ON lamp of the switch box and the High Voltage ON Lamp "H.V." of BPS1600 light up during electrostatic coating. There will be a graph and numeric values of an air flow rate and a gun current displayed on the monitor page of the touch panel so that the air and the electrostatic coating ON/OFF states can be checked.
- ⑥ When the nozzle comes too close to a grounding object, the safety device (OCL) becomes activated and the buzzer goes off. High voltage will stop.
- ⑦ Return the trigger to reset.
- ⑧ When the work is cancelled or completed, press the OFF button switch of the switch box or the operation off/reset switch of BPS1600 "OFF/RESET".

For cautionary instructions during the coating work, please read the instruction manual of the electrostatic hand gun well.

8.1 Security Levels

The indication of the touch panel changes according to the security levels SLv (protected with 4-digit passwords). The security levels are categorized in five stages; SLv0, SLv1, SLv2, SLv3, and SLv4.

The passwords vary depending on the security levels, and no change is allowed.

One security level is maintained until the power is turned off or the user resets.

SLv	Operation level	Password	Description
0	Coating worker		Is able to handle necessary operations of daily coating works. Can check recipes (coating conditions), production results, alarm history, etc.
1	Maintenance technician	0001	Is able to edit the settings and to practice maintenance. Can set up the recipes (coating conditions), delete alarm history, and reset the counter.
2	Administrator	1212	Is able to handle the administrator tasks. Can set up standard flow rates.
3	Manufacturer	8847	Is able to set up according to delivery specifications. Can set up about errors.
4	Manufacturer	5280	DO NOT change unless necessary.

8.2 Numerical Value and Text Input

The key window will appear when numeric values and texts are needed to be entered for the graph, time adjustment, recipe setting, device setting, BPS setting and others.

8.2.1 Numerical Value Input

The key window for numeric value inputs will appear when the user touches the time on the upper left side of the graph page, the time of the date and hour section on the date & time adjustment page, or a numerical value on other setting pages.

Press "ENT" after entering a numerical value. The key window will be closed and the numerical value will be confirmed.

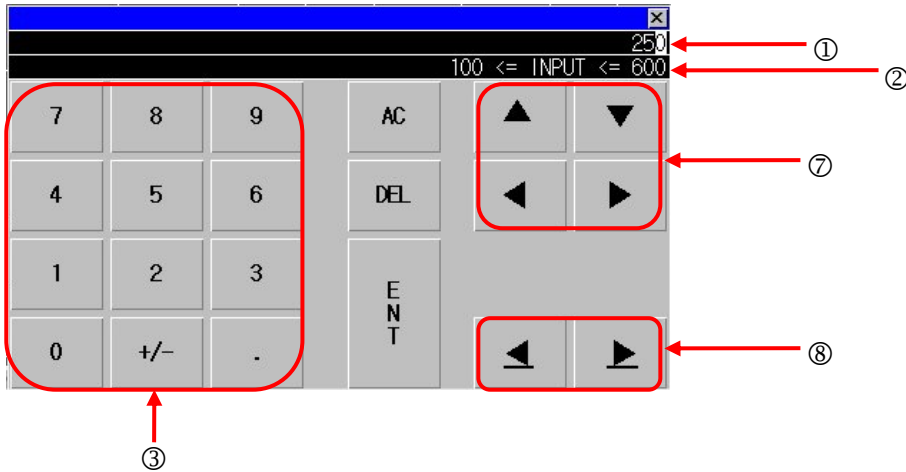

No.	Item	Description
1		Displays an entered numerical value.
2	<= INPUT <=	Displays an entered range of numerical values.
3		Inputs numerical values and decimal point.
4	AC	Deletes all numerical values.
5	DEL	Deletes the last digit of a numerical value.
6	ENT	Confirms a numerical value after input.
7		Moves the input cursor to another input section.
8		Moves the input cursor.
9	x	Closes the key window.

8.2.2 Text Input



The key window for text inputs will appear when the user touches the color code on the recipe (setting) page.

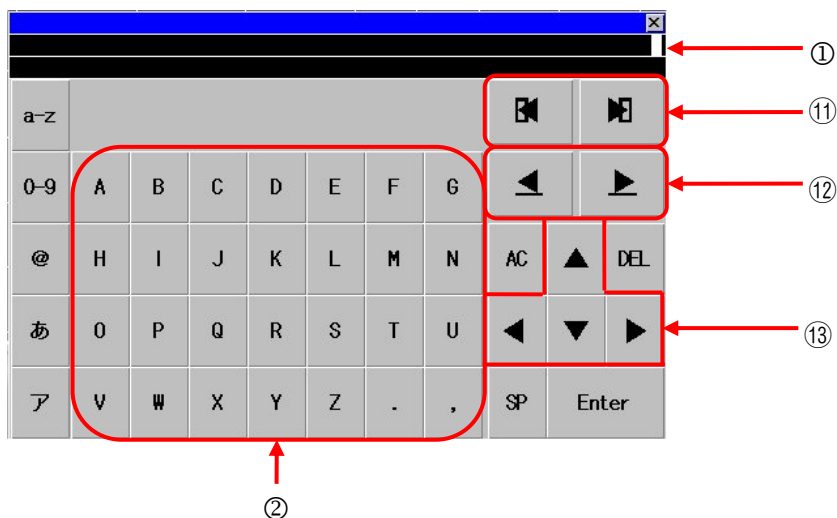

Press “ENT” after entering texts. The key window will be closed and the text input will be confirmed.



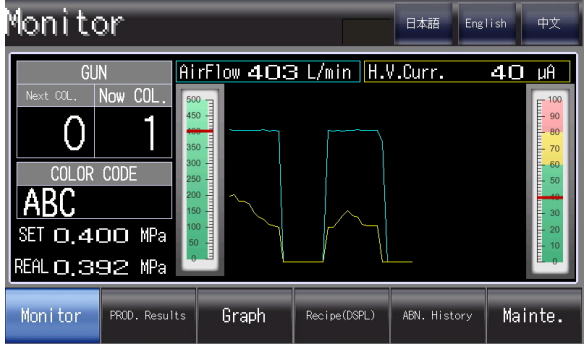





No.	Item	Description
1		Displays an entered text.
2		Inputs characters, numbers, symbols, and Japanese characters.
3	a-z	Changes the keys of the area described in 2 to lower-case alphabets.
4	0-9	Changes the keys of the area described in 2 to numbers.
5	@	Changes the keys of the area described in 2 to symbols.
6	あ	Changes the keys of the area described in 2 to Japanese Hiragana.
7	ア	Changes the keys of the area described in 2 to Japanese Katakana.
8	AC	Deletes all texts.
9	DEL	Deletes the text at most upper left.
10	SP	Enters a space.
10	Enter	Confirms the text after input.
11		Changes the keys of the area described in 2.
12		Moves the input cursor to another input section.
13		Moves the input cursor.
14	x	Closes the key window.

8.3 SLv0 Display



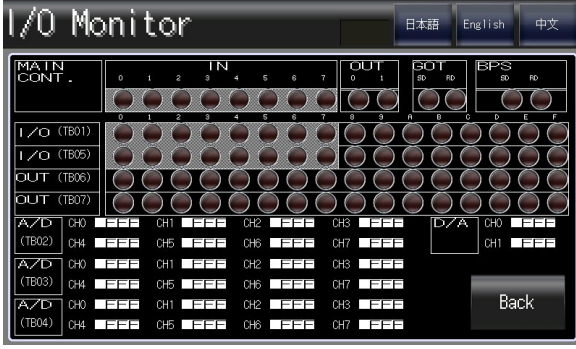

No	Display	Description
1		<p>Start-up screen It appears at power ON until communication between the main board and the touch panel is established. It allows to view the program versions of the ASC900 touch panel and the main board. DSP: Touch panel CPU: Main board</p> <p>“Skip”: To go to the monitor page.</p> <p>On all pages except for the alarm history screen, the language on the display can be switched by operating “Japanese”, “English”, and “Chinese” buttons.</p>
2		<p>Monitor Page (Main Page) It displays a graph and numerical values of an air flow rate and a gun current and allows to view air and electrostatic coating ON/OFF states. The graph is updated every second. It also displays the gun No. in use and the setting air pressure, Current air pressure. If the user has entered color codes, the corresponding color code will be also displayed according to the gun in use.</p> <p>* To display the Gun No. to be used for a specified color, the user is required to add an input terminal.</p>
3		<p>PROD. Results Page It displays records of coating applied to workpieces. Production results are indicated as “Time”. To confirm production results, the gun in use needs to be changed or the operation needs to be turned off. “GUN No”: No. of gun used “Air [MPa]”: Setting air pressure “Air [L/min]”: Air flow rate (average value) “SPRAY [sec]”: Gun ON time “SprayCNTR”: Gun ON count “Current”: Gun current (average value) “PaintUsage”: Coating consumption (converted value)</p> <p>①② To view different production results. TOP : To view the latest production result. Page ^ : To view the 10 newer production results. Page V : To view 10 older production results. Bottom: To view the oldest production result.</p> <p>③ To save production result data in the CSV format into a SD card.</p>

No	Display	Description
4		<p>Graph Page The graph is updated every second from analog data.</p> <p>Yellow: GUN No. Displayed on ten fold scale. Red: Air flow Blue: Air Press. Displayed on thousand fold scale. Green: H.V. Current On the right axel. (Others on the left axel.) Blue : Error·Caution Error occurring point. (Error : 105 Caution : 55) Pink : Electric current peak value (during trigger ON) Orange : Electric current bottom value. (during trigger ON)</p> <p>① To view different graphs. Zoom: To change the horizontal axel (time). Cursor: To move the cursor. Scroll: To move to other sections of the graph. Page: To go to other pages of the graph. Jump to List: To view the graph based on the time set up at upper left. Update: To view/update the graph again.</p> <p>② To save graph data in the CSV format into a SD card.</p>
5		<p>Recipe (DSPL) Page1 It displays a recipe (coating conditions) of each gun.</p> <p>The contents of a recipe can be changed after SLV1 is chosen and the page moves to the maintenance (setting) page.</p>
6		<p>Recipe (DSPL) Page2 It displays a recipe (Normal current range) of each gun.</p> <p>The contents of a recipe can be changed after SLV1 is chosen and the page moves to the maintenance (setting) page.</p>

No	Display	Description
7		<p>Alarm History Page (SLv0) It displays errors detected with BPS1600 and ASC900.</p> <p>It displays error codes, error names, error time, and recovery time. The gun No. will be displayed on * of G* regarding errors of each gun.</p> <p>“CSV” : To save Alarm History data in the CSV format into a SD card.</p> <p>“Alarm Monitor” : To go to the on-going error page.</p> <p>*It lists up to 1,000 errors and will be overwritten from older history.</p>
8		<p>Alarm Monitor Page It displays currently on-going errors.</p> <p>Error details (estimated cause and measure) will be displayed when the user double-clicks on an error item.</p> <p>“BUZZER STOP” : To stop the buzzer of the control panel. “RESET (OPE.OFF)” : To reset an error. The operation is also shut down.</p>
9		<p>Mainte. Page (SLv0) It allows to select the counter page, I/O monitor page, or password page.</p>
10		<p>COUNTER Page (SLv0) It displays the spray ON time and the spray ON/OFF counts by each gun.</p>

No	Display	Description
11		<p>I/O Monitor Page It displays communication status of I/O, A/D, and D/A.</p>
12		<p>PASSWORD Page The user can enter the password on this page. It displays the current security level.</p> <p>“PASSWORD”: To view the window for the security level authentication. Press “0-9” to change the key type and then enter the 4-digit number of the password. Lastly press “Enter”.</p> <p>“Release”: To reset to SLv0.</p>

8.4 Additional Display at SLv1

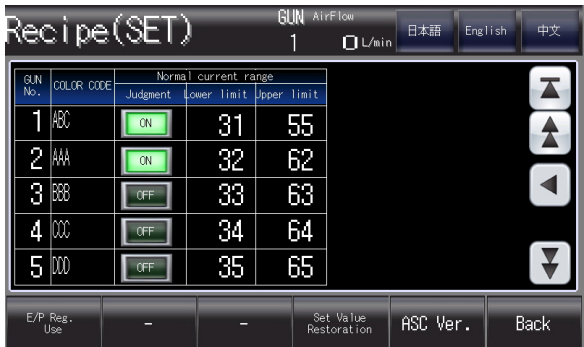

No	Display	Description
13		<p>Alarm History Page (SLv1) It displays errors detected with BPS1600 and ASC900.</p> <p>Hold “Delete”: To delete the selected error. Hold “Dele All”: To delete all errors.</p> <p>Errors will not be deleted if they are not recovered.</p>
14		<p>Mainte. Page (SLv1) It allows to select the date & time adjustment page, counter page, I/O monitor page, password page, or recipe (setting) page.</p>
15		<p>Date & Time adj. Page The user can set up the clock.</p> <p>Enter the current time in the time setting section and press “ENTER” to change the current date and hour.</p>
16		<p>COUNTER Page (SLv1) It displays the spray ON time and the spray ON/OFF counts by each gun.</p> <p>Hold “RESET”: To reset individual counter values.</p> <p>Hold “Set Value Restoration” : To reset to the counter value saved on a SD card.</p>

No	Display	Description
17		<p>Recipe (setting) page1 The user can set up a recipe (coating conditions) for each gun on this page.</p> <p>COLOR CODE: To enter up to 8 alphanumeric characters for the color code or up to 4 Japanese characters.</p> <p>AirPRESS.: To set up air pressure.</p> <p>AirFLOW: To view the standard air flow rate selected on the standard value renewal page.</p> <p>Discharge: To enter a discharge amount of measured coating as a guideline.</p> <p>H.V.[kV]: To set up gun voltage.</p> <p>Gun Type: To set up with “30”, “40”, or “60”.</p> <p>H.V.: To set up with “Use” or “Not Use”.</p> <p>OCL: To set up a value for OCL.</p> <p>di/dt: To set up a value for di/dt.</p> <p>Const.: To set up a value for rated current.</p> <p>Hold “Set Value Restoration” : To reset to the recipe setting saved on a SD card.</p> <p>“ASC Ver.”: To go to the start-up screen.</p> <p>“Back”: To go to Mainte. Page. Memorize the set value to SD card. ※It takes about 10 seconds.</p> <p>① To display the gun No. in use and the current air flow rate.</p> <p>② To switch “E/P Reg. Use” and “E/P Reg. Non-use”.</p>
18		<p>Recipe (setting) page2 The user can set up a recipe (Normal current range) for each gun on this page.</p> <p>COLOR CODE: To enter up to 8 alphanumeric characters for the color code or up to 4 Japanese characters.</p> <p>Normal current range Judgment: Select the judgement is finished/not yet.</p> <p>Lower limit: Set the minimum value of appropriate current range.</p> <p>Upper limit: Set the maximum value of appropriate current range.</p>

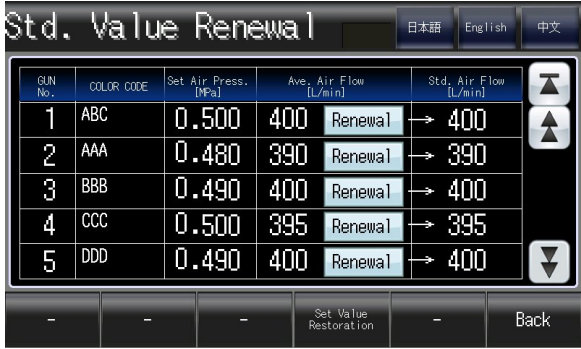

8.5 Additional Display at SLv2

No	Display	Description
19		<p>Mainte. Page(SLv2) It allows to select the date & time adjustment page, counter page, I/O monitor page, password page, standard value renewal page, or recipe (setting) page.</p>
20		<p>Std. Value Renewal Page The user can set up a standard flow rate for each gun on this page.</p> <p>“Renewal”: To set up the average air flow rate as standard air flow rate.</p> <p>The average air flow rate and standard air flow rate of the corresponding gun are reset to 0 when the setting air pressure is changed.</p>

8.6 Additional Display at SLv3

No	Display	Description
21		<p>Mainte. Page (SLv3) It allows to select the date & time adjustment page, counter page, I/O monitor page, password page, standard value adjustment page, recipe (setting) page, device setting page or BPS setting page.</p>
22		<p>Initial Setting Page1 The user can select the ASC900 setting (1 to 6) on this page.</p> <p>“Next Page”: To go to the Initial Setting Page 2.</p> <p>“Back”: To go to Mainte. Page.</p> <p>Memorize the set value to SD card. ※It takes about 10 seconds.</p> <p>Hold “Set Value Restoration” : To reset to the device setting that is saved to a SD card.</p>

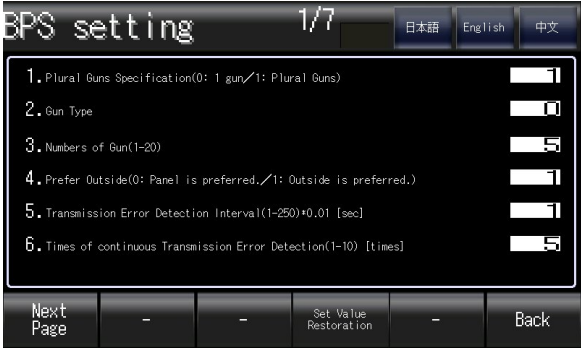
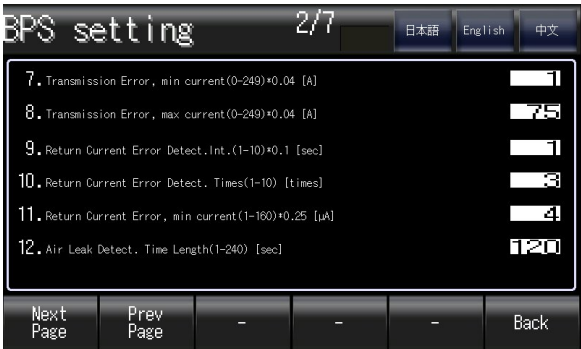
No	Display	Description
23	<p>Initial Setting 2/6</p> <p>日本語 English 中文</p> <p>7. Air flow ERROR upper limit(10-100) [Std. Air Flow * *L/min] 100</p> <p>8. Air flow ERROR upper limit Detect.Int.(1-10)*0.1 [sec] 5</p> <p>9. Air flow ERROR upper limit Detect. Times(1-99) [times] 100</p> <p>10. Air flow ERROR lower limit(10-100) [Std. Air Flow * *L/min] 100</p> <p>11. Air flow ERROR lower limit Detect.Int.(1-10)*0.1 [sec] 5</p> <p>12. Air flow ERROR lower limit Detect. Times(1-99) [times] 100</p> <p>Next Page Prev Page - - - Back</p>	<p>Initial Setting Page 2</p> <p>The user can select the ASC900 setting (7 to 12) on this page.</p> <p>“Next Page”: To go to Initial Setting Page 3.</p> <p>“Prev Page”: To go to Initial Setting Page 1.</p> <p>“Back”: To go to Mainte. Page.</p>
24	<p>Initial Setting 3/6</p> <p>日本語 English 中文</p> <p>13. Air leakage(0:OFF/1:ERR①/2:ERR②/3:ERR③/4:WRN) 4!</p> <p>14. Air flow(H)(0:OFF/1:ERR①/2:ERR②/3:ERR③/4:WRN) 4!</p> <p>15. Air flow(L)(0:OFF/1:ERR①/2:ERR②/3:ERR③/4:WRN) 4!</p> <p>16. More Than One Gun Choice(0:OFF/1:ERR①/2:ERR②/3:ERR③/4:WRN) 0</p> <p>17. Next Color Gun Notice Yes/No 0</p> <p>Next Page Prev Page - - - Back</p>	<p>Initial Setting Page 3</p> <p>The user can select the ASC900 setting (13 to 17) on this page.</p> <p>“Next Page”: To go to Initial Setting Page 4.</p> <p>“Prev Page”: To go to Initial Setting Page 2.</p> <p>“Back”: To go to Mainte. Page.</p>
25	<p>Initial Setting 4/6</p> <p>日本語 English 中文</p> <p>18. Electro-pneumatic Regulator Max.(0.500-0.900) [MPa] 0.9000</p> <p>19. Flowmeter Max.(200-1000) [L/min] 500</p> <p>20. Air Leakage Judg. Flow Rate(10-50) [L/min] 20</p> <p>21. Air Press(H) SET Air Press.(0.03-0.10) [MPa] 0.05</p> <p>22. Air Press(H) Detect.Int.(1-10)*0.1 [sec] 5</p> <p>23. Air Press(H) Detect. Times(1-99) [times] 10</p> <p>Next Page Prev Page - - - Back</p>	<p>Initial Setting Page 4</p> <p>The user can select the ASC900 setting (18 to 23) on this page.</p> <p>“Next Page”: To go to Initial Setting Page 5.</p> <p>“Prev Page”: To go to Initial Setting Page 3.</p> <p>“Back”: To go to Mainte. Page.</p>
26	<p>Initial Setting 5/6</p> <p>日本語 English 中文</p> <p>24. Air Press(L) SET Air Press.(0.03-0.10) [MPa] 0.05</p> <p>25. Air Press(L) Detect.Int.(1-10)*0.1 [sec] 5</p> <p>26. Air Press(L) Detect. Times(1-99) [times] 10</p> <p>27. Air Press(H)(0:OFF/1:ERR①/2:ERR②/3:ERR③/4:WRN) 4!</p> <p>28. Air Press(L)(0:OFF/1:ERR①/2:ERR②/3:ERR③/4:WRN) 4!</p> <p>29. Mainte. Counter Spray ON counter (0-99999) [Times] 0</p> <p>Next Page Prev Page - - - Back</p>	<p>Initial Setting Page 5</p> <p>The user can select the ASC900 setting (24 to 29) on this page.</p> <p>“Next Page”: Go to Initial Setting Page 6.</p> <p>“Prev Page”: Go to Initial Setting Page 4.</p> <p>“Back”: To go to Mainte. Page.</p>
27	<p>Initial Setting 6/6</p> <p>日本語 English 中文</p> <p>30. Mainte. Counter Spray time (0-99999) [hours] 0</p> <p>31. Spray ON counter count up(0:OFF/1:ERR①/2:ERR②/3:ERR③/4:WRN) 4!</p> <p>32. Spray time count up(0:OFF/1:ERR①/2:ERR②/3:ERR③/4:WRN) 4!</p> <p>33. 0</p> <p>34. 0</p> <p>35. 0</p> <p>- Prev Page - - - Back</p>	<p>Initial Setting Page 6</p> <p>The user can select the ASC900 setting (30 to 35) on this page.</p> <p>“Prev Page”: To go to Initial Setting Page 5.</p> <p>“Back”: To go to Mainte. Page.</p>

No	Display	Description
28		<p>BPS setting Page1</p> <p>The user can select the BPS1600 setting (1 to 6) on this page.</p> <p>“Next Page”: To go to BPS setting Page 2.</p> <p>“Back”: To go to Mainte. Page.</p> <p>Memorize the set value to SD card.</p> <p>※It takes about 10 seconds.</p> <p>Hold “Set Value Restoration”</p> <p>: To reset BPS setting that is saved to a SD card.</p>
29		<p>BPS setting Page 2</p> <p>The user can select the BPS1600 setting (7 to 12) on this page.</p> <p>“Next Page”: To go to BPS Setting Page 3.</p> <p>“Prev Page”: To go to BPS Setting Page 1.</p> <p>“Back”: To go to Mainte. Page.</p>
30		<p>BPS setting Page 3</p> <p>The user can select the BPS1600 setting (13 to 18) on this page.</p> <p>“Next Page”: To go to BPS Setting Page 4.</p> <p>“Prev Page”: To go to BPS Setting Page 2.</p> <p>“Back”: To go to Mainte. Page.</p>

No	Display	Description
31		<p>BPS setting Page 4</p> <p>The user can select the BPS1600 setting (19 to 24) on this page.</p> <p>“Next Page”: To go to BPS Setting Page 5.</p> <p>“Prev Page”: To go to BPS Setting Page 3.</p> <p>“Back”: To go to Mainte. Page.</p>
32		<p>BPS setting Page 5</p> <p>The user can select the BPS1600 setting (25 to 30) on this page.</p> <p>“Next Page”: Go to BPS Setting Page 6.</p> <p>“Prev Page”: Go to BPS Setting Page 4.</p> <p>“Back”: To go to Mainte. Page.</p>
33		<p>BPS setting Page 6</p> <p>The user can select the BPS1600 setting (31 to 36) on this page.</p> <p>“Next Page”: To go to BPS Setting Page 7.</p> <p>“Prev Page”: To go to BPS Setting Page 5.</p> <p>“Back”: To go to Mainte. Page.</p>
34		<p>BPS setting Page 7</p> <p>The user can select the BPS1600 setting (37 to 40) on this page.</p> <p>“Prev Page”: To go to BPS Setting Page 6.</p> <p>“Back”: To go to Mainte. Page.</p>

9

Various Settings

Any change of the settings shall be made by those who have been duly trained.

9.1 Recipe Setting (SLv1 or higher)

Gun No.	COLOR CODE	AirPRESS. [MPa]	AirFLOW [L/min]	Discharge [mL/min]	H.V. [kV]	Gun Type	H.V.	OCL [μ A]	di/dt [μ A]	Const. [μ A]
1										
2										
3										
4										
5										
6										
7										
8										
9										
10										

Gun No.	Normal current range Judgment	Normal current range Lower limit [μ A]	Normal current range Upper limit [μ A]
1			
2			
3			
4			
5			
6			
7			
8			
9			
10			

Name	Setting range	Default value	Remark
COLOR CODE	-	-	Up to 8 alphanumerical characters or up to 4 Japanese characters.
AirPRESS.	0.010 to 0.600	0.100	Setting air pressure [MPa]
AirFLOW	-	0	Standard air flow rate selected on the standard value renewal page [L/min]
Discharge	0 to 500	0	Enter a discharge amount of coating that is measured with a measuring cylinder. It is used to calculate coating consumption (guideline). [mL/min]
H.V.[kV]	10 to 60	30	Setting voltage for 60kV [kV]
	6 to 40		Setting voltage for 40kV [kV]
	5 to 30		Setting voltage for 30kV [kV]
Gun Type	30/40/60	30	Select the gun with appropriate maximum kV. (Example) HB5000 "60" HB6000 "30"
H.V.	Use/Not Use	Use	Select whether to use as electrostatic gun or not. Electrostatic gun: "Use" Spray gun (non-electrostatic): "Not Use"
OCL	30 to 160	80	OCL detection value [μ A]
di/dt	2 to 40	30	di/dt detection value [μ A]
Const.	25 to 80	80	Constant current setting value [μ A] * Set up with a multiple number of 5.
Normal current range Judgment	ON/OFF	OFF	Select whether perform judgement of appropriate. ON The judgement is finished. OFF The judgement is not finished yet.
Normal current range Lower limit	0 to 80	0	Set the minimum value of appropriate current range. [μ A]
Normal current range Upper limit	0 to 80	80	Set the maximum value of appropriate current range. [μ A]

9.2 Device Setting (SLv3)

No.	Setting item	Min.	Max.	Default	Setting
1	Language (1: Japanese 2: English 3: Chinese)	1	3	1	
2	Type Sel.(0:MPa/1:L/min)	0	1	0	
3	Gun Choice Mistake (0: OFF 1: ERR① 2: ERR② 3: ERR③ 4: WRN)	0	4	0	
4	H.V. ON Air Flow Rate [L/min]	10	99	50	
5	H.V. OFF Air Flow Rate [L/min]	10	50	20	
6	Air Leak Detect. Time Length [sec]	1	240	5	
7	Air flow ERROR upper limit [Std. Air Flow + **L/min]	10	100	30	
8	Air flow ERROR upper limit Detect.Int. *0.1 [sec]	1	10	5	
9	Air flow ERROR upper limit Detect. Times [times]	1	99	10	
10	Air flow ERROR lower limit [Std. Air Flow - **L/min]	10	100	30	
11	Air flow ERROR lower limit Detect.Int. *0.1 [sec]	1	10	5	
12	Air flow ERROR lower limit Detect. Times [times]	1	99	10	
13	Air leakage (0: OFF 1: ERR① 2: ERR② 3: ERR③ 4: WRN)	0	4	4	
14	Air flow(H) (0: OFF 1: ERR① 2: ERR② 3: ERR③ 4: WRN)	0	4	4	
15	Air flow(L) (0: OFF 1: ERR① 2: ERR② 3: ERR③ 4: WRN)	0	4	4	
16	More Than One Gun Choice (0: OFF 1: ERR① 2: ERR② 3: ERR③ 4: WRN)	0	4	0	
17	Next Color Gun Notice (0:NO/1:YES)	0	1	0	
18	Electro-pneumatic Regulator Max. [MPa]	0.500	0.900	0.900	
19	Flowmeter Max. [L/min]	200	1000	500	
20	Air Leakage Judg. Flow Rate [L/min]	10	50	20	
21	Air Press(H) SET Air Press. [Std. AirPRESS. + **MPa]	0.03	0.10	0.05	
22	Air Press(H) Detect.Int. *0.1 [sec]	1	10	5	
23	Air Press(H) Detect. Times [times]	1	99	10	
24	Air Press(L) SET Air Press. [Std. AirPRESS. - **MPa]	0.03	0.10	0.05	

No.	Setting item	Min.	Max.	Default	Setting
25	Air Press(L) Detect.Int. *0.1 [sec]	0.1	1.0	0.5	
26	Air Press(L) Detect. Times [times]	1	99	10	
27	Air Press(H) (0: OFF 1: ERR① 2: ERR② 3: ERR③ 4:WRN)	0	4	4	
28	Air Press(L) (0: OFF 1: ERR① 2: ERR② 3: ERR③ 4:WRN)	0	4	4	
29	Mainte. Counter Spray ON counter [times]	0	999999	0	
30	Mainte. Counter Spray time [hours]	0	99999	0	
31	Spray ON counter count up (0: OFF 1: ERR① 2: ERR② 3: ERR③ 4: WRN)	0	4	4	
32	Spray time count up (0: OFF 1: ERR① 2: ERR② 3: ERR③ 4: WRN)	0	4	4	

9.2.1 Error Detection Setting

		READY	H.V.	Air	ERROR	WARNING	How to reset Error
0	OFF	○	○	○	×	×	-
1	ERR①	○	×	○	○	×	Release Gun trigger. Push [RESET(OPE,OFF)]
2	ERR②	×	×	○	○	×	Push [RESET(OPE,OFF)]
3	ERR③	○	×	○	○	×	Push [RESET(OPE,OFF)]
4	WRN	○	○	○	×	○	Push [RESET(OPE,OFF)] Counter reset*1

*1 For maintenance counter

9.3 BPS Setting (SLv3)

No.	Setting item	Min.	Max.	Default	Setting
1	Plural Guns Specification	1	1	1 (Fixed)	1
2	Gun Type	0	0	0 (Fixed)	0
3	Numbers of Gun	1	20	5	
4	Prefer Outside (0:Panel is preferred./1: Outside is preferred.)	0	1	1	
5	Transmission Error Detection Interval *0.01[sec]	1	250	1	
6	Times of continuous Transmission Error Detection [times]	1	10	5	
7	Transmission Error, min current *0.04[A]	0	249	1	
8	Transmission Error, max current *0.04 [A]	0	249	75	
9	Return Current Error Detect.Int. *0.1 [sec]	1	99	1	
10	Return Current Error Detect. Times [times]	1	99	30	
11	Return Current Error, min current *0.25[μ A]	1	160	4	
12	Air Leak Detect. Time Length [sec]	1	240	120	
13	Constant current [μ A]	25	80	80	
14	Cont.OCL Detect. Times [times]	1	20	1	
15	OCL Detect. Value [μ A]	30	160	160	
16	OCL Dull Time Length *0.1 [sec]	0	20	5	
17	OCL Dull Degree *0.1 [times]	10	50	20	
18	di/dt Buffer	1	8	4	
19	di/dt Weighted Average	10	255	50	
20	Cont. di/dt Detect. Times [times]	1	10	1	
21	di/dt Detect Interval [2^n msec]	2	7	5	
22	di/dt Dull Time Length *0.1 [sec]	0	20	10	
23	di/dt Dull Degree *0.1 [times]	10	50	30	
24	OCL (0: OFF 1: ERR① 2: ERR② 3: ERR③)	0	3	1	
25	di/dt (0: OFF 1: ERR① 2: ERR② 3: ERR③)	0	3	0	
26	Transmission Err. (0: OFF 1: ERR① 2: ERR② 3: ERR③)	0	3	2	
27	Return Current Err. (0: OFF 1: ERR① 2: ERR② 3: ERR③)	0	3	0	
28	Time Over (0: OFF 1: ERR① 2: ERR② 3: ERR③)	0	3	2	
29	Const. Current Time Over (0: OFF 1: ERR① 2: ERR② 3: ERR③)	0	3	0	
30	Err. Relay Output Delay *0.1 [sec]	0	50	0	

No.	Setting item	Min.	Max.	Default	Setting
31	Const. Current Time Over Detecting Time [sec]	1	60	10	
32	Current Err.(Spray OFF) (0: OFF 1: ERR① 2: ERR② 3: ERR③)	0	3	2	
33	H.V. Setting during Operation	0	1	0	
34	Main Monitorings	0	5	0	
35	Correction value of Transmission Error, max current [%]	1	10	6	
36	Recipe Preservation(0:NO/1:YES)	0	1	0	

9.3.1 Error Detection Setting

		READY	H.V.	Air	ERROR	WARNING	How to reset Error
0	OFF	○	○	○	×	×	-
1	ERR①	○	×	○	○	×	Release Gun trigger. Push [RESET(OPE,OFF)]
2	ERR②	×	×	○	○	×	Push [RESET(OPE,OFF)]
3	ERR③	○	×	○	○	×	Push [RESET(OPE,OFF)]

9.4 Error Display

9.4.1 BPS1600 Errors

Fault type	Detailed description	Probable cause	Remedy
OCL <OCL> Error Code G*(0001)	When the output current exceeds the set value	(1) Approach of the gun and ground (2) Dirt outside the gun (3) Metal bridge (4) Faulty gun	(1) Increase the spraying distance (2) Wash the gun. (3) Wash the paint path Decrease the set voltage (4) Replace the gun
di/dt <di/dt> Error Code G*(0002)	When variation of the gun current exceeds the di/dt setting value	(1) Approach of the gun and ground	(1) Increase the spraying distance
Tr.Cur.(L) <CABLE> Error Code G*(0004)	When power transmission current is below the lowest faulty transmission current	(1) Improper connection of the connection cable (2) Replace the connection cable	(1) Reconnect the connection cable (2) Replace the connection cable
Tr.Cur.(H) <CABLE> Error Code G*(0008)	When power transmission current exceeds the highest faulty transmission current	(1) Short circuit of the connection cable (2) Faulty gun	(1) Replace the connection cable (2) Replace the gun
Re.Cur.(L) <OCL, CABLE> Error Code G*(0010)	When gun electric current is below the lowest faulty gun current	(1) Damaged or dirty charge electrode (2) Improper connection of the connection cable (3) Open circuit of the connection cable (4) The set voltage is low (5) Faulty gun	(1) Replace or wash the charge electrode (2) Reconnect the connection cable (3) Replace the connection cable (4) Increase the set voltage (5) Replace the gun
Air leakage <TIMEOVER> Error Code G*(0040)	When the remote signal keeps ON exceeding the set time	(1) The spray ON time long	(1) Review the set value (initial value: 120 seconds)
Const. Current Time Over <OCL, TIMEOVER> Error Code G*(0080)	When the constant current state lasts for the constant current Timeover detection time or longer	(1) Approach of the gun and ground (2) Dirt outside the gun (3) Metal bridge (4) Faulty gun	(1) Increase the spraying distance (2) Wash the gun. (3) Wash the paint path Decrease the set voltage (4) Replace the gun
Return Current Err. (Spray OFF) <OCL, CABLE> Error Code (02XX)	When the gun current exceeds the level that is four times higher than the lowest gun current at high voltage OFF or exceeds the level that is 10 times higher than the number of continued gun current faults	(1) Faulty BPS1600	(1) Replace BPS1600

Fault type	Detailed description	Probable cause	Remedy
Transmission Err. (Spray OFF) <CABLE> Error Code (04XX)	When the transmission current exceeds the level that is four times higher than the lowest gun transmission current at high voltage OFF or exceeds the level that is 10 times higher than the number of continued transmission current faults	(1) Faulty BPS1600	(1) Replace BPS1600

< >: LED display of BPS1600

If you cannot restore the device with the above remedy, contact us.

9.4.2 ASC900 Errors

Fault type	Detailed description	Probable cause	Remedy
ASC Air leakage Error Code G*(0100)	When air leakage between the air leakage threshold flow rate and the high-voltage ON air flow rate lasts for the air leakage detection time or longer	(1) Air leakage	(1) Retighten the air pipe
Air flow(H) Error Code G*(0200)	When the air flow rate is higher than the standard air flow rate by a specified amount and lasts for the number of the detection interval multiplied by the continuous generation counts	(1) Adjustment of a pattern valve (2) Looseness of Retaining nut (3) Air leakage (4) Faulty digital flow switch	(1) A pattern valve is returned Standard value renewal is performed (2) Retighten the retaining nut (3) Replace part of an air leakage point (4) Replace digital flow switch
Air flow(L) Error Code G*(0400)	When the air flow rate is lower than the standard air flow rate by a specified amount and lasts for the number of the detection interval multiplied by the continuous generation counts	(1) Adjustment of a pattern valve (2) Air leakage (3) Faulty digital flow switch	(1) A pattern valve is returned Standard value renewal is performed (2) Replace part of an air leakage point (3) Replace digital flow switch
More than one gun use Error Code G*(0800)	*Default value: Invalid When multiple guns are used simultaneously	(1) More than one gun is used at the same time	(1) Only 1 gun is used
Air Press(H) Error Code G*(1000)	When the air pressure is higher than the setting air pressure by a specified amount and lasts for the number of the detection interval multiplied by the continuous generation counts	(1) Faulty E/P regulator	(1) Replace E/P regulator
Air Press(L) Error Code G*(2000)	When the air pressure is lower than the setting air pressure by a specified amount and lasts for the number of the detection interval multiplied by the continuous generation counts	(1) The supply air pressure is low (2) Ball valve on the air filter IN side is closed (3) Faulty E/P regulator	(1) Adjust supply air pressure (2) Open the ball valve (3) Replace E/P regulator

Fault type	Detailed description	Probable cause	Remedy
Spray counter count up Error Code G*(4000)	When the spray ON count by each gun exceeds the setting spray ON count on the maintenance counter	(1) Long-term use of the gun	(1) Reset the counter after maintenance.
Spray time count up Error Code G*(8000)	When the spray ON time by each gun exceeds the setting spray ON time on the maintenance counter	(1) Long-term use of the gun	(1) Reset the counter after maintenance.
Gun choice mistake Error Code (01XX)	[Option] When any gun other than those selected by a superior device is triggered	(1) A gun different from directions is used	(1) Choose a gun again
BPS DATA ERROR Error Code (0800)	When a BPS setting value exceeds the setting range of BPS1600	(1) H.V. or Gun Type of the recipe is wrong (2) Program version is wrong	(1) Review the set value (2) Upgrades in a right program
Memory Clear Error Code (1000)	When RAM contents are deleted	(1) Long term power-off	(1) Please use just as it is
EEPROM Fault Error Code (2000)	When RAM contents are deleted and EEPROM is faulty	(1) Faulty ASC900	(1) Replace ASC900
Clock Fault Error Code (4000)	When oscillation stop of the clock IC is detected during activation	(1) Long term power-off	(1) Please set Clock
BPS comm. Fault Error Code (8000)	When there is a communication error between ASC900 and BPS1600	(1) Communication cable contact failure between ASC900 and BPS1600 (2) Communication setting of BPS1600 is invalid	(1) Reconnect the communication cable (2) The communication setting is made effective

If you cannot restore the device with the above remedy, contact us.

10

Consumable Parts List

The usable life of the following consumable parts vary depends on the environment of usage.

Its recommend for replace them as for the following reference value of usable life.

Part No.	Part name	Qty	Durable life	Remark
447-0021	Switching Power Supply	1	5 years	AVR1, Main unit side
E0D2050054100	Switching Power Supply	1	5 years	For ASC900, Door side
301-0079	E/P Regulator	1	Replace as necessary.	
303-0027	Air Filter	1	Replace as necessary.	
E0QX0100U0500	Protective Sheet	1	Replace as necessary.	For touch panel 4 sheets to be delivered as accessory

11.1 Cautionary Instructions Prior to Maintenance

This maintenance manual is intended for maintenance purpose only.

Maintenance should be practiced according to the maintenance manual by those who have received maintenance training.

Please see the instruction manual of the electrostatic hand gun for maintenance of the electrostatic hand gun.

Contact us for maintenance to other faults.

11.2 Maintenance Methods

11.2.1 Cleaning Control Panel Outer Sides and Touch Panel

Turn off the power of the control panel and use a soft cloth with neutral detergent or ethanol absorbed. Wipe off dirt lightly.

* Avoid using acetone, benzene, toluene and other thinner materials. These may cause a deformed or peeled protection sheet for the touch panel.

11.2.2 Replacing Protection Sheets

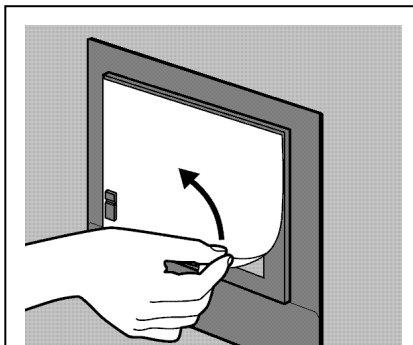

① Peel off an old protection sheet and clean the surface of ASC900.

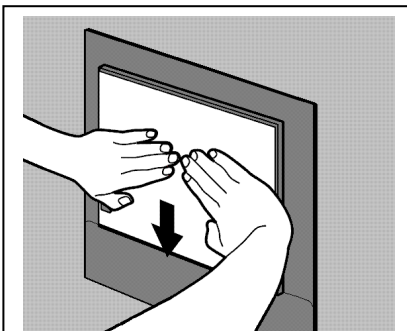

② Peel a paper liner off the back side of a new protection sheet and attach the adhesive side to the display section.

* Pay attention not to leave a gap on the adhesive side when attaching the protection sheet.

* See [10 Consumables List] for part numbers of the protection sheets.

<Replacement timing of the protection sheets>

Please make visual check on the protection sheets as daily inspection and ensure the state. Too much dirt or scratches deteriorates visibility and may result in a malfunction. Immediate replacement is recommended.

11.2.3 Replacing Air Filter

They should be replaced 2 years after start of use or when pressure drops to 0.1MPa. Please prepare the element AF40P-060S used for the air filter AF40-03D-2-A.

① Close the ball cock BV to stop air supply to the air filter.

② Rotate the drain cock at the bottom of the air filter to left and eject air out of the path.

Keep hands away from ejected air when handling the drain cock.

③ Remove the case assembly.

Press down the lock button of the case assembly. Rotate to left or right by 45° while lifting up the case assembly. Pull to the case assembly and remove.

④ Remove the baffle, element and deflector.

Rotate the baffle to left with hand and remove the baffle, element and deflector.

⑤ Mount the deflector.

Pay attention to the mounting direction (into the direction where the element enters the concave side) and set to the body assembly.

⑥ Mount a new element.

Insert the element into the concave side of the deflector.

⑦ Mount the baffle.

Pay attention to the mounting direction (into the direction where the element enters the convex side) while inserting into the element.

⑧ Fix the baffle, element and deflector.

Rotate the baffle to right with hand until it lightly joins the element and deflector. Then, make a rightward half rotation for tightening. The tightening torque is approx. 0.9N·m.

⑨ Mount the case assembly.

Align the fitting mark of the body with that of the case assembly and insert the case assembly to the body. Rotate to either right or left by 45° (until the lock button clicks up) to attach the case assembly. Check that the lock button is up and locked.

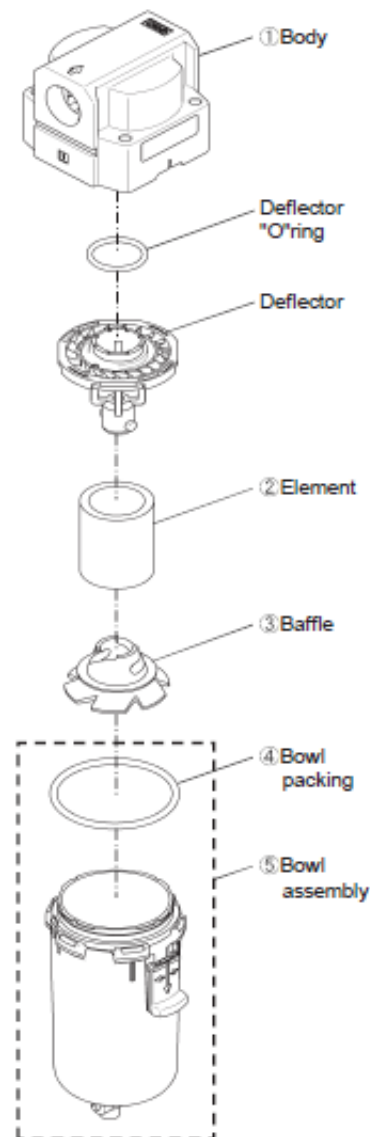

Cautions to be taken at BPS1600 in the Control Box

- * The Controller should be so fixed that its front surface stays as vertical as possible.
- * Much care should be taken to prevent vibration or shock to the Controller.

(1) Attaching of moisture-proof packing

Before assembly, confirm that the moisture-proof packing is provided.

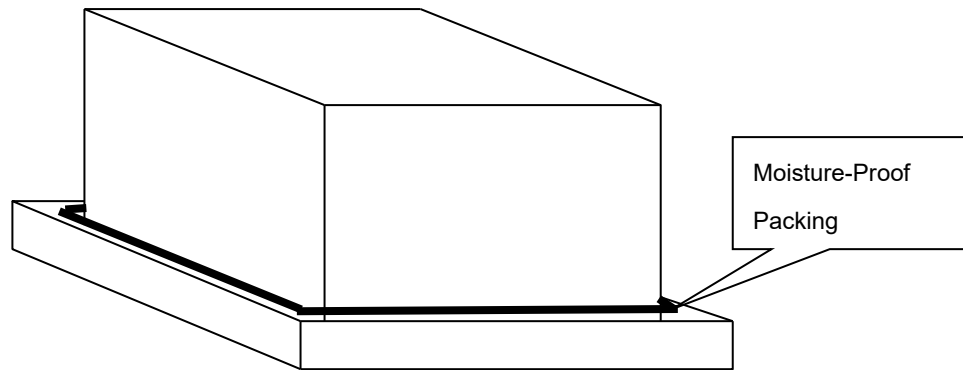

Joining part of the packing should come to underside to prevent penetration of any liquid into the Control Panel.

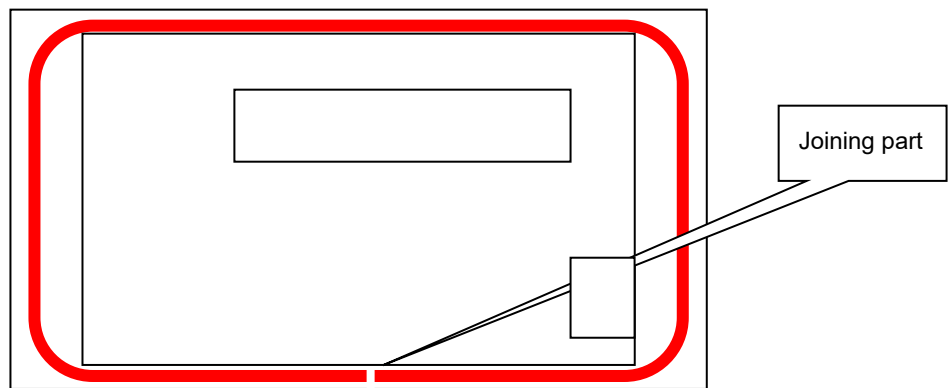

View from rear side

(2) Put the Controller into the Panel through front opening.

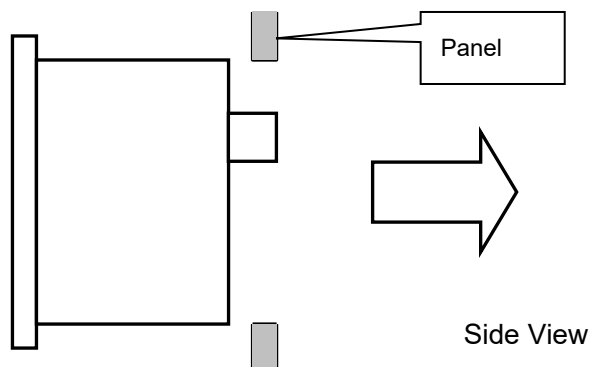

Side View

(3) Fix back side of the front panel to Control panel with fixture

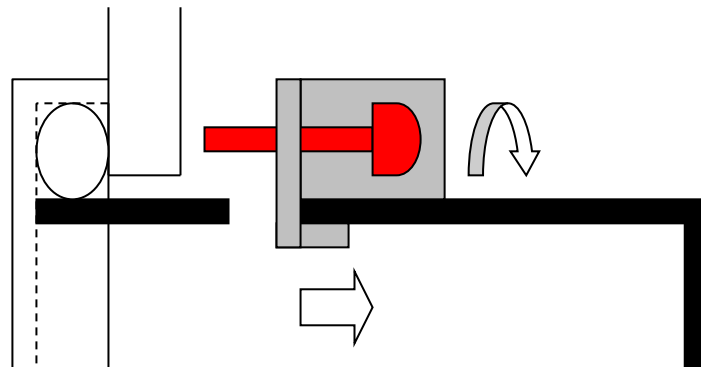

- Insert fixing fixtures into fixing holes at 8 points of top, bottom, left and right.
- Then draw the fixtures slightly back.
- Tighten screws of fixtures with plus head driver.
 - * Tightening torque should be 0.5 to 0.6N•n for adequate moisture-proof effect.
 - * Too tight fixing may cause damage the equipment.

13

SD Card Handling

13.1 Data to Save on SD Card

- Files in a SD card (This is an explanation about the DATA folder only.)

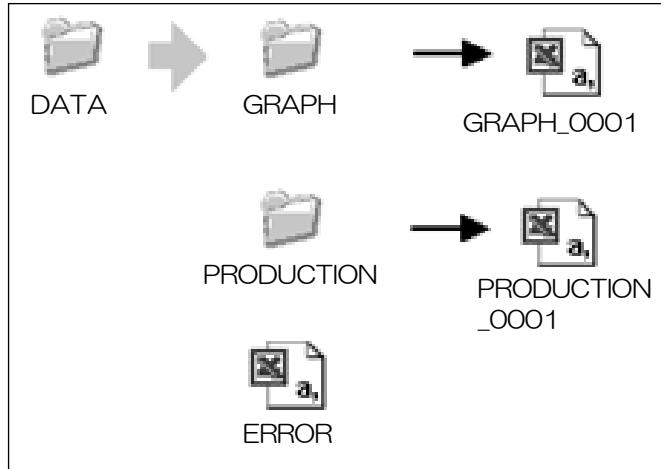

Item	File name	Description
Graph	GRAPH_****.csv	43200 data x 14 files This is 7-day data as it is one data per second. See [P.21 Graph page].
Production	PRODUCTION_****.csv	1000 data x 1000 files See [P.20 Production result page].
Alarm History	ERROR.csv	It lists up to 1,000 errors. See [P.22 Alarm History Page(SLv0)].

* **** in "****.csv" indicates a serial number.

* When data is full, older data is overwritten.

13.2 SD Card Insertion and Ejection

13.2.1 Removing the SD Card

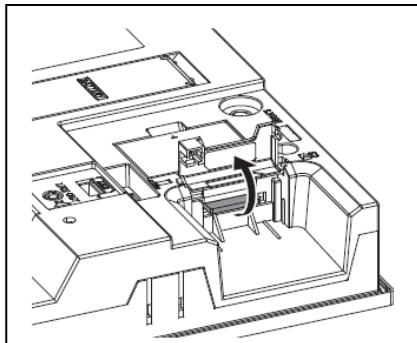

(1) Open the SD card cover.

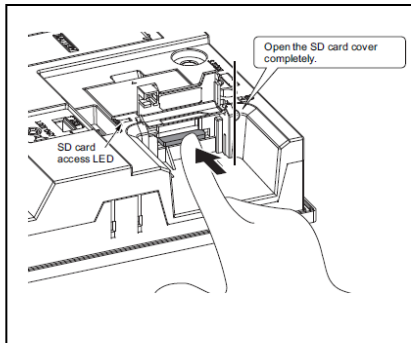

(2) Open the SD card cover completely, and check that the SD card access LED is off. Then, push in the SD card to remove it.

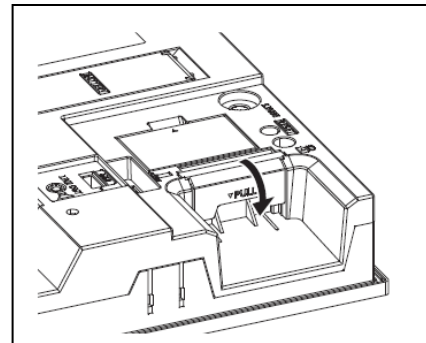

(3) Close the cover of the SD card interface.

CAUTION

Device malfunction or non-operability

- Support a SD card with hand while taking it out from the graphic panel. Failure to do so may lead to a fall followed by card damage or failure.
- Do not take out a SD card or turn off the device power while the card access LED is lighting. That may lead to a damage in the SD card or a file.
- Do not wet a SD card with liquid. Also, fall or impact must be avoided. That may lead to a card damage or failure.

13.2.2 Installing the SD Card

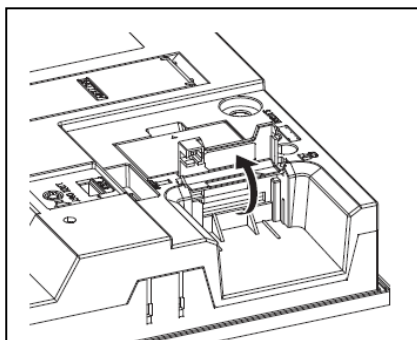

(1) Open the SD card cover.

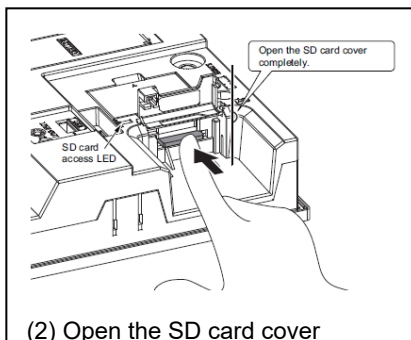

(2) Open the SD card cover completely, and check that the SD card access LED is off. Then, hold an SD card with its front side facing up, and insert the card into the SD card interface.

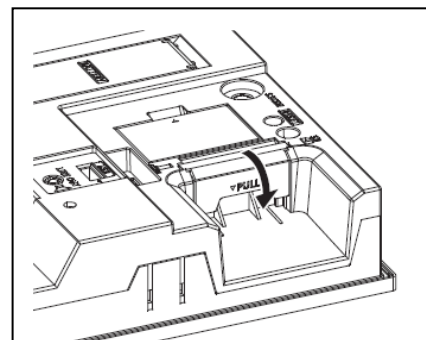

(3) Push and close the SD card cover until it clicks.

14

For Electropneumatic Regulator Faults

If the electropneumatic regulator or ASC900 is broken down, air may not be ejected. Until the faulty part is replaced, it can operate with the guns all at the same air pressure (static pressure) instead of the electropneumatic gun.

- ① Set the ball valve of “N.O.” in the control panel to “Close” and the ball valve of “N.C.” to “Open”.

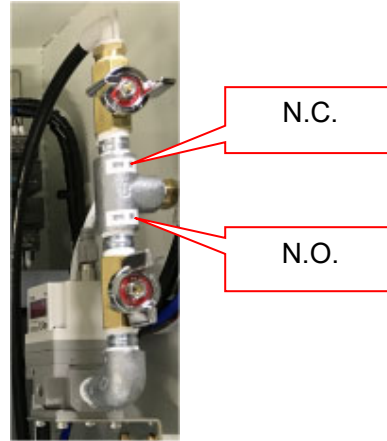

- ② Adjust the manual regulator under the control panel while checking the pressure with a barometer.

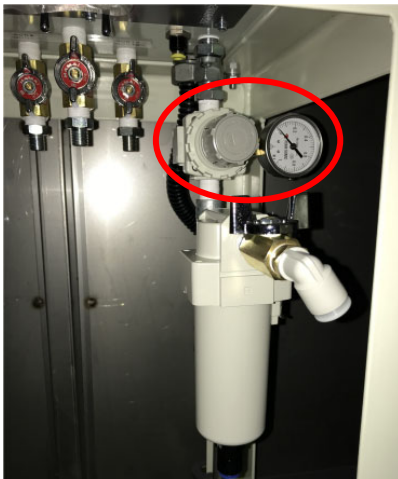

- ③ Hold “Electropneumatic Regulator Use (hold)” on the “Recipe (setting)” page for 3 seconds or longer to change to “Electropneumatic Regulator Not Use (hold)”.

See [8.4 Additional Display at SLv1]]

Recipe (SET)											
GUN AirFlow											
1 403 L/min											
GUN No.	COLOR CODE	AirPRESS. [MPa]	AirFLOW [L/min]	Discharge [mL/min]	H.V. [kV]	Gun Type	H.V.	OCL	di/dt	Const. [uA]	
1	ABC	0.400	401	0	40	50	Use	80	30	80	▲
2	AAA	0.300	0	0	60	50	Use	80	30	80	▲
3	BBB	0.350	0	0	30	30	Not Use	80	30	80	▶
4	CCC	0.300	0	0	60	50	Use	80	30	80	▼
5	DDD	0.200	0	0	60	50	Use	80	30	80	▼
E/P Reg. Use		-	-	Set Value Restoration	ASC Ver.	Back					

Revision level	Date	Content of revision	Program version
First edition	February 1, 2018	–	–
2nd edition	June 13, 2018	Change Program	Ver1.00
3rd edition	October 31, 2018	Change Program	Ver1.01
4th edition	September 9, 2020	Change Program	Ver1.10
5th edition	August 18, 2022	Warranty revision	Ver1.10

ASAHI SUNAC CORPORATION (the "Company") shall provide the original purchaser (the "Purchaser") with warranty service for a period of one (1) year from the date of purchase of the product, as follows:

- Should you find defects in design or workmanship with regard to parts, ship them back to the Company, with freight prepaid. The Company shall repair or replace the parts free of charge and reimburse the freight charges, provided that, as a result of an inspection and investigation of the parts conducted by the Company, the defects are deemed to be attributable to the factors within the Company's responsibility.
- In the following cases, free after-sales service is not provided.
 1. Failure resulting from an inappropriate method of installing this equipment.
 2. Failure resulting from a use method not conforming to this instruction manual or mishandling.
 3. Failure resulting from insufficient maintenance management of this equipment and incorrect handling such as non-conformance to the procedures specified in this instruction manual.
 4. Failure resulting from unauthorized alteration or structure change of this equipment without the Company's consent.
 5. Failure due to force majeure such as earthquake, disaster, flood disaster or lightning.
 6. Warranty for consumables worn or deteriorated even in the case where this equipment is used correctly.
 7. Repair after the machine has been used outside Japan, and shipping cost.
 8. In addition to the above, failure due to circumstances beyond our control.
- As for items such as parts purchased by the Company from another manufacturer, the warranty of that manufacturer shall apply.
- As for any parts deemed to be defective, the Company shall not be held liable for any expenses beyond the provision of repair or replacement parts free of charge.
- The Company shall not be held liable for any damage to the Purchaser caused by factors not attributable to the Company, such as misuse of product, etc.

【MEMO】

-
- When a transfer of title of this equipment takes place, please see to it that this Operation and Maintenance Manual is handed over to the new owner.
 - This equipment is manufactured in compliance with the Laws and Regulations of Japan.
In the rare eventuality of this equipment being used outside Japan, compliance with the safety standards of the relevant countries is of course mandatory.
-

5th Edition: August 18, 2022



Leading Manufacturer of Coating FA Systems
ASAHI SUNAC CORPORATION
Head office & Factory: 5050 Asahimae-cho, Owariasahi, Aichi 488-8688 Japan

TEL 81-561-52-0717 FAX 81-561-54-8847
e-mail: ctrd01@sunac.co.jp

5th Edition: August 18, 2022