

# Operation and Maintenance Manual

## Electrostatic Controller

# BPS260



This manual contains important information on warnings and cautions. Read the manual thoroughly before starting to operate the equipment, and follow the instructions.

Always keep the manual handy until such time as the equipment is no longer being used. If your manual is lost or worn badly, do not hesitate to contact our agency, which is closest to you, or the Asahi Sunac Corporation, directly, and ask us to send you a new one.

# Preface

---

Thank you very much for choosing our Electrostatic controller (BPS260).

In order to keep the equipment in the best condition for an extended period, please carefully read this manual before use. Above all, the specifications, warnings and prohibitory or cautionary instructions shown herein shall be fully understood and observed during the use of the equipment.

The equipment covered by this manual is designed for industrial coating work. It shall be used by those who have been duly trained regarding the handling and scope of application and have an understanding of the operating procedure.

If you need further information about this manual, please call us described on the back cover by specifying the "model" and "serial No." of your equipment.

<b>1</b>	For Safety and Correct Use	1
<b>2</b>	Overview	5
<b>3</b>	Specifications	6
<b>4</b>	Names and Functions of Components	8
	4.1 Names of components	8
	4.2 Functions of components	9
<b>5</b>	Operating Procedures	9
	5.1 Starting procedure	9
	5.2 Memory selection procedures	10
	5.2.1 Memory selection from the control panel	10
	5.2.2 External memory selection procedure	10
<b>6</b>	Liquid Crystal Display	11
	6.1 General sequence of pages	11
	6.2 Description of pages and bilingual indications	12
	6.2.1 Display mode	12
	6.2.2 Fault pages	14
	6.2.3 Setting mode	15
	6.3 Transitions among pages	16
	6.3.1 View mode	16
	6.3.2 I/O monitor pages	17
	6.3.3 Peak hold pages	19
	6.3.4 Fault record pages	20
	6.3.5 Setting mode	20
	6.3.6 Memory specific settings	21
<b>7</b>	Classification of Faults	22
	7.1 Classification of faults	22
<b>8</b>	Output Voltage vs Output Current Curve	23
<b>9</b>	Other Functions	24
	9.1 Fault record	24
	9.2 Setting the clock	24
	9.3 Keyboard locking function	25
<b>10</b>	Parameters	26
	10.1 Memory specific settings	26
	10.2 Setting mode	26
<b>11</b>	Wiring	27
	11.1 Outside dimensions	27
	11.2 Names and functions of components	28
	11.2.1 Names of components	28
	11.2.2 Functions of components	29
	11.3 Example of wiring	33

	11.4	Optional devices	34
	11.4.1	Optional external monitor	34
<b>12</b>		Consumable Parts List	34
<b>13</b>		BPS260 Front Panel Cleaning Method	34
<b>14</b>		Repair Record	35
<b>15</b>		Appendixes	36
	15.1	Password page	36
	15.2	Initialization of parameters	36
	15.3	System parameter settings	37
	15.3.1	Description of pages and bilingual indications	37
	15.3.2	Transition among pages	39
	15.3.3	List of parameters	43
	15.4	Simple operation mode	46
	15.5	WB mode	47
<b>16</b>		Revision Record	48
<b>17</b>		Warranty	49



Contents of this instruction manual shall be fully understood and the instructions shown herein strictly observed.

Using the machine without following instructions in this manual may lead to bodily injury or damage to properties.

The safety measures described herein are the minimum requirements and additional measures may also be required. All requirements provided by laws and legislations as well as rules and guidelines laid by your company or office shall be observed.

The cautionary instructions shown below shall be construed as minimum basic requirements for safety in the use of our product.

- Cautionary instructions are shown in three levels as defined below.

 <b>WARNING</b>	Calls the user's attention to a situation that may lead to bodily injury and describes how to avoid that situation.
 <b>CAUTION</b>	Calls the user's attention to a situation that may lead to damage or breakdown to the equipment and describes how to avoid that situation.
<b>NOTE</b>	Gives important or helpful information.

- \* Please remember that the situation mentioned under  CAUTION may also lead to a serious disaster under certain circumstances. All instructions are important for your safety and prevention of machine disorder and shall be strictly observed.

This manual only describes the BPS260.

For the electrostatic gun and coating equipment to be connected with it, see the respective instruction manuals.

## WARNING

### Adequate conditions of use for the product

The product covered by this instruction manual consists of a controller specially designed to supply a high-frequency power to the automatic electrostatic gun contained in a high-voltage generator described in the specifications and control high-voltage charges on the gun.

Do not use other than the specified guns.

**The product is not explosion-proof. Do not use it in hazardous areas Zone 0 to 2 specified in IEC 60079-10.**

Because this product has a panel mount structure, be sure to install the product to the control panel having a protection class of IP54 or higher. Provide the control panel with the power switch because the product has no power on/off switch.

If you have any doubt about the intended use of the product or materials used for it, please consult us.

Please note that using the product under conditions other than specified above will be considered as abuse unless specially approved by us and may lead to an accident.

### Danger from abuse

#### <<General safety requirements>>

- Thoroughly check the supply voltage before use. Applying a voltage other than selected may lead to a failure and/or fire.
- The controller uses a high voltage and must be correctly grounded.  
Failure to do this may lead to a failure, electric shock, injury and/or fire.  
Always ground the grounding terminal (with class D grounding work).  
Do not fail to tighten the terminal block mounting screws and attach the connectors.
- Do not modify the wiring when it is alive.
- **The controller is not explosion-proof. Do not use it in hazardous areas Zone 0 to 2.**  
**Only explosion-proof control panels are allowed to be used in hazardous areas Zone 0 to 2.**
- Avoid using the product in a place where it will be subject to a higher temperature or humidity or excessive vibration. Doing so may lead to a failure.
- If the controller fails, immediately stop it and turn it off. After checking that the controller has been discharged, short the charging terminal to the ground.  
If the protector is activated or a fuse is blown, do not turn on the power switch.
- Do not operate the controller with the door open. Do not touch the charger and hot parts inside the controller. Doing so may lead to a burn, injury and/or electric shock.

## WARNING

### To prevent fire and explosion

#### <<Sources of ignition>>

The electrostatic coating process uses the electrostatic phenomenon at a high voltage to positively generate static electricity.

Static electricity is also generated while paint is running through a pump or hose.

If any part of the coating machine or any metallic object around it is not correctly grounded, electrostatic sparks will be generated. The sparks may ignite volatile components of a solvent, paint mist from the spray nozzle, suspended particles or another combustible substance to cause a fire or explosion, possibly resulting in a serious injury or damage to the equipment.

- Check that the coating machine, all metallic objects around it and the products to be coated have been grounded. If not, a fire or explosion may be caused by electrostatic sparks.
- The spraying area and the vicinity of the coating equipment shall be well ventilated.
- Do not bring the high-voltage electrode at the tip of the gun or any of its peripheral parts close to a product to be coated or the ground or bring them into contact during the electrostatic coating process. Unknowingly using a faulty gun may generate big sparks and also cause damage to the nozzle and electrode.
- When interrupting or finishing the coating work, never fail to turn off the BPS260 and, five seconds after that, bring the corona pin at the tip of the gun into contact with a grounding wire or grounded metallic object for at least 10 seconds to remove residual charges.
- Do not plug in or out the coating machine or another electric appliance within a radius of 7 to 8 meters from the spraying area.
- Do not perform the coating work in the vicinity of an open flame, lamp or another source of ignition.
- Never smoke in the spray coating area.
- If you feel shocked by static electricity even slightly while handling the coating machine, immediately stop the coating work and check each component for grounding.  
Do not restart the coating work until the cause is located and corrective action is taken.
- The input power and connecting cables, if damaged, may generate sparks to cause a fire or explosion. Protect the cables from damage.
- Fire extinguishers with a sufficient capacity must be provided in the spray coating area.

#### <<Grounding>>

To prevent danger from static electricity, completely ground all metallic or conductive objects in the spray coating area (ones in use and booths, hangers, coated products, pumps, coating machines and equipment, fire extinguishers, flooring materials, etc. around them). If no adequate ground is provided, perform the grounding work (class D grounding =  $100\Omega$  or less) using the methods specified by the Technical Standards for Electric Equipment. The methods for grounding the coating equipment are described below

## WARNING

- Grounding the working floor

The working floor shall be constructed of conductive materials and grounded.

Spill paint and stains on the floor, if any, shall be immediately wiped off to maintain the floor clean.

- Grounding the paint hose

Use a completely grounded paint hose.

When using an extended paint hose, check that it has been completely grounded.

- Grounding the air hose

Use a completely grounded air hose.

- Grounding the electrostatic gun

The electrostatic gun firmly connected with correctly grounded air and paint hoses is considered to be adequately grounded.

- Completely ground the BPS260. Connect a grounding wire to the grounding terminal on the controller for complete grounding (class D or equivalent grounding).

- Grounding the products to be coated

If objects are metal, grounding resistance should be under  $1k\Omega$ . If objects are plastic, grounding resistance should be under  $1M\Omega$ . Contaminants on hangers and grounding clips shall be immediately removed to keep them grounded. For detail, follow instructions of the fire station with jurisdiction in your region.

- Grounding the human body

All persons entering the spray coating area shall wear anti-static clothes with embedded grounding wires and anti-static shoes with clean soles (conductive shoes with a resistance about  $10M\Omega$ ) so that their bodies will not be charged with static electricity.

- Grounding the paint container

Do not use any paint container other than lidded metallic ones. Provide an exclusive paint port and put the container on a grounded floor or table to completely ground the paint container body.

If it is impractical to ground it through a floor or table, connect an exclusive grounding wire to the paint container to completely ground it. In addition, the coating work must be performed with the paint container lid closed.

- Grounding the cleaning solvent container

Dipping or spouting cleaning solvent may generate static electricity.

If a metallic container not adequately grounded is used for collecting cleaning solvent, it will be charged with a great amount of static electricity to pose a possibility of danger. Use a metallic container put on a grounded floor or table to completely ground the container body. Never put it on a non-conductive material such as corrugated cardboard.

If it is impractical to ground it through a floor or table, connect an exclusive grounding wire to the solvent container to completely ground it.

When cleaning a paint pump or reducing the pressure, firmly hold the hose mouthpiece at the bottom of the gun extension onto the rim of a grounded solvent container and then pull the trigger.

# 2

## Overview

This equipment consists of a controller that supplies power to the automatic electrostatic gun contained in a high-voltage generator and controls high-voltage charges on the gun.

Two guns can be controlled and the high-voltage output of each can be independently switched on/off.

The operation status of the controller and that of the gun are indicated on the front panel of the controller.

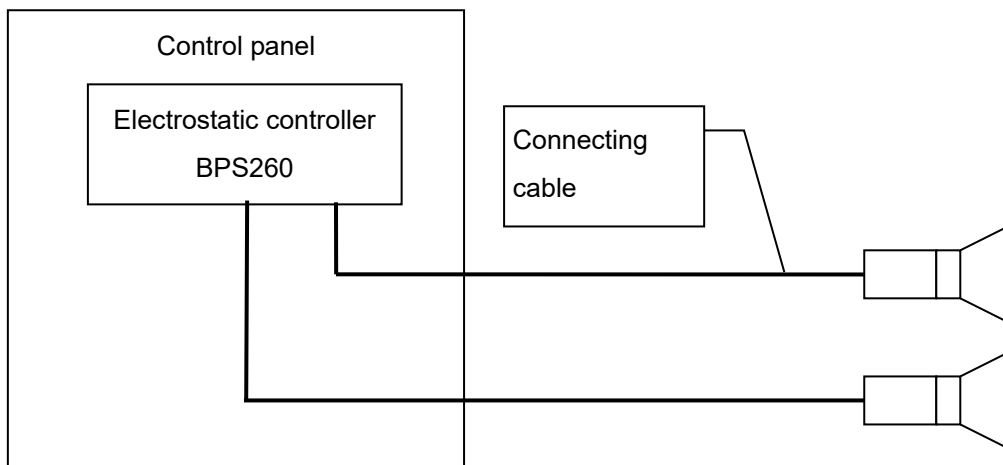

Part number list for electrostatic controller

No.	Name	Part no.	Apecification
1	BPS260	445-0159	Japanese and English written together
2		445-0160	English version

# 3

## Specifications

Item	Gun type	-60kV max. automatic electrostatic gun
Product name		Electrostatic controller
Model		BPS260
Number of connectable guns		2 or less
Safety devices		Constant current protection circuit Absolute over-current detection type shut-down circuit (OCL) Variable over-current detection type shut-down circuit (di/dt, WAOCL) Feed wire alarm circuit Return wire alarm circuit
Voltage generated under no load		DC-60kV+/-3kV    *DC-30kV
Rated output current		80μA (-37kV)
Constant current setting		25 to 80μA+/-5μA (at intervals of 1μA)
Shorting current		90μA+/-10μA
Over-current thresholds		Absolute: 30 to 80μA (at intervals of 1μA) Variable: 2 to 25μA (at intervals of 1μA)
Output voltage adjustment		-20 to -60kV (at intervals of 1kV)    *-10 to -30kV
Transmission voltage		AC24V+/-2V
Transmission frequency		20kHz+/-1kHz
Conditions of use		Ambient temperature: 0 to 45°C Humidity: 20 to 85% (no condensation allowed) Altitude: 2000m or less Atmosphere : Shall not be exposed to corrosive gas, dust, vapor, water drops and direct rays of the sun.
Protection class		Outside the enclosure: IP54 Inside the enclosure: IP10 (Input power terminal block)
Input power		AC100 to 240V
Voltage tolerance		+/-10%
Power supply frequency		50/60Hz
Consumption current		0.6 to 0.4A
Over voltage category		II
Pollution degree		2
Weight		Approx. 4.0kg
Memory backup		2 weeks with super-capacitor
Adjustment standard		C E Marking • LVD (2014/35/EC)    EN61010-1 : 2010 • EMC (2014/30/EC)    EN61000-6-2 : 2005 EN61000-6-4 : 2007+A1 : 2011 • ATEX (2014/34/EC)    EN50050-1 : 2013

\*When WB mode ON

Specific conditions of use

These electrostatic gun and controller shall only be used in one of the following combinations.

Certificate No.	Controller	Gun
03ATEX5418X	BPS260	EAB90 T4389 Twin T4389A

# 4

## Names and Functions of Components

### 4.1 Names of components

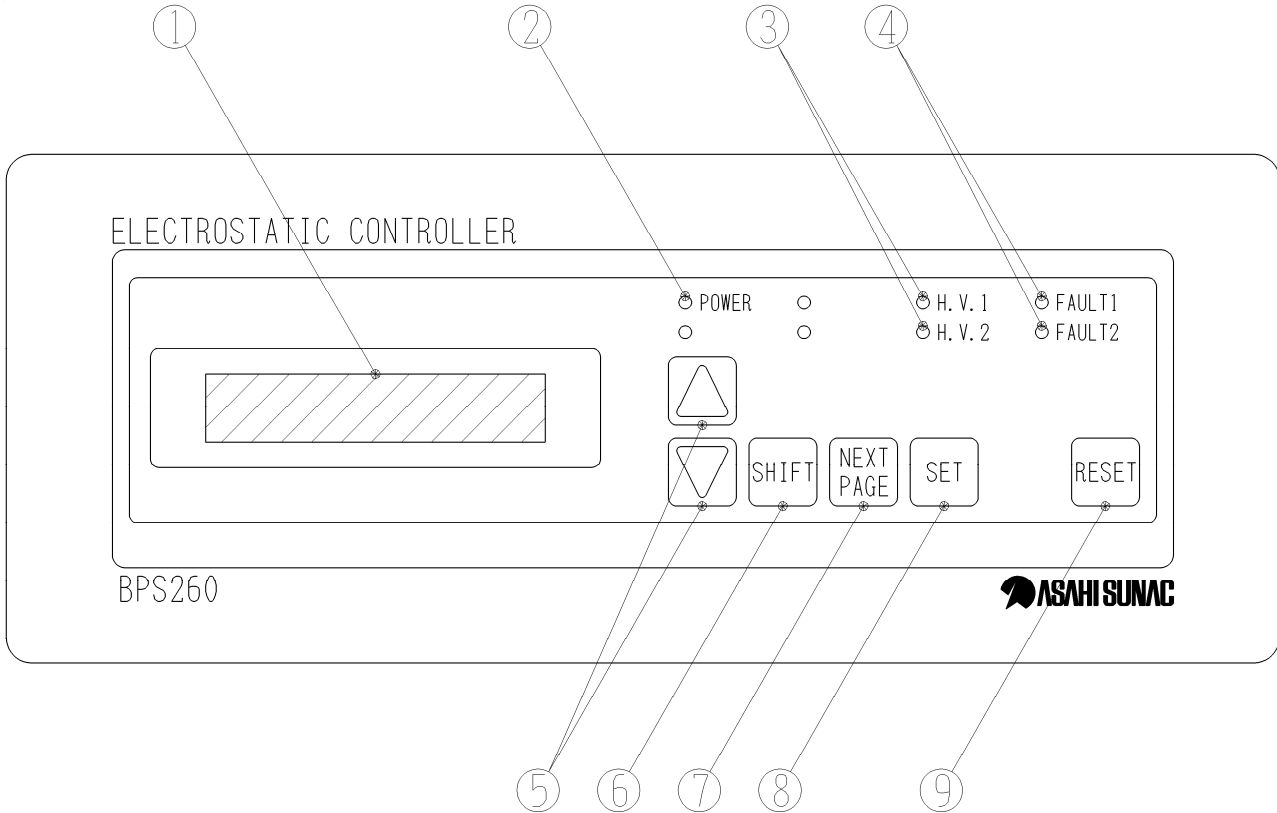

No.	Name	No.	Name
①	Liquid crystal display	②	Power lamp "POWER"
③	High voltage lamps "H.V.1" (for gun 1) "H.V.2" (for gun 2)	④	Fault lamps "FAULT 1" (for gun 1) "FAULT 2" (for gun 2)
⑤	Up/down keys "△ and ▽"	⑥	Shift key "SHIFT"
⑦	Next page key "NEXT PAGE"	⑧	Set key "SET"
⑨	Reset key "RESET"		

**Note:** The controller shape and specifications may be changed without notice to reflect improvements, etc.

## 4.2 Functions of components

- ① Liquid crystal display  
Indicates the gun status, fault record and system parameter settings.
- ② Power lamp "POWER"  
Lights when power is supplied to the input power terminal box.
- ③ High voltage lamps "H.V.1" and "H.V.2"  
Lights when the remote ON signal is received and indicates that a high voltage has been generated.
- ④ Fault lamps "FAULT 1" and "FAULT 2"  
Blinks when a fault is pending.
- ⑤ Up/down keys "△ and ▽"  
Used to increase or decrease the setting value.
- ⑥ Shift key "SHIFT"  
Used to move the cursor. Press this key and the NEXT PAGE key at the same time to return to the previous page.
- ⑦ Next page key "NEXT PAGE"  
Used to proceed to the next page on the liquid crystal display.
- ⑧ Set key "SET"  
Used to view details on the liquid crystal display or confirm the clock setting or password.
- ⑨ Reset key "RESET"  
Used to reset the equipment from an error. The liquid crystal display returns to the main monitor page.

# 5

## Operating Procedures

### 5.1 Starting procedure

- Check that the equipment has been grounded (with class D grounding work).

### WARNING

Incomplete grounding may lead to a failure, electric shock, injury, fire and/or explosion.

- Check the supply voltage.

### WARNING

Using a power supply other than selected may lead to a failure and/or fire.

- ① Supply power.
- ② The power lamp "POWER" lights and the program version number is indicated on the liquid crystal display for about three seconds.  
(Example)  

BPS260 Version1.00
write:06/01/2009
- ③ Send a remote signal to "REM1" or "REM2" to transmit high-frequency power to the high-voltage generator for the relevant gun while the signal is received. (Refer to contents No.11)
- ④ As the nozzle gets too close to a grounded object, the safety device is activated to stop the high-voltage generator. (Refer to 「6,3,4」 for resetting.)
- ⑤ Turn off the input power when finishing the work.

## 5.2 Memory selection procedures

- When the memory number is changed, each fault detection is dulled.
- Memory No. 8 is only available when the optional serial gateway is used.

### 5.2.1 Memory selection from the control panel

Select "0 (control panel)" on the password page asking the "memory selection method."

>MEM. SELECT  
 PANEL:0/OUTSIDE:1 x

- ① If "SET" is pressed on an ordinary page, the memory number to be changed is indicated under the currently selected memory number.
  - ② Select a desired memory number using "△" or "▽."
  - ③ Press "SET" again to confirm (when the control panel takes precedence or the external memory selection terminals have been set to "000").
- \* When you have chosen to select a memory for each gun, the memory cannot be selected from the control panel.

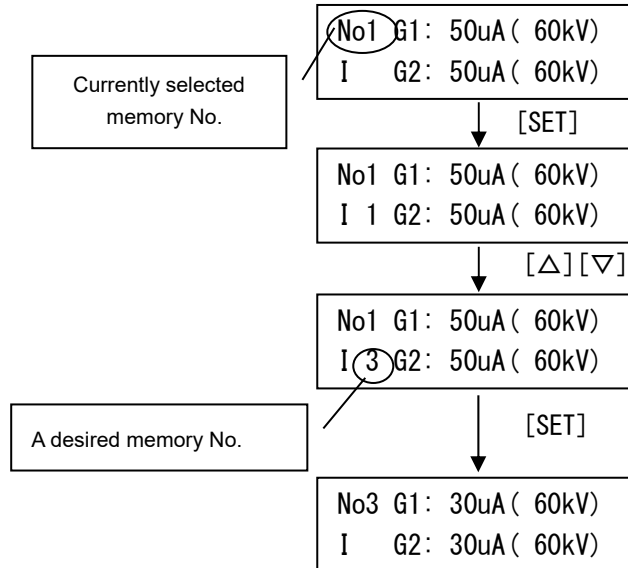

### 5.2.2 External memory selection procedure

- A memory can be selected by shorting external memory selection terminals 1, 2 and 3 on the I/O terminal block to IN COM.
- With all of external memory selection terminals 1 to 3 open, the control panel takes precedence even if the external memory selection method has been selected. In this case, memory No. 1 will be selected.
- When the memory selection is linked, the same memory is selected for both guns according to the external memory selection signal for gun 1.

When you have chosen to select a memory for each gun, the memory is selected according to the external memory selection signal for each gun.

	Precedence given to control panel	No.1	No.2	No.3	No.4	No.5	No.6	No.7
SET1	0	1	0	1	0	1	0	1
SET2	0	0	1	1	0	0	1	1
SET3	0	0	0	0	1	1	1	1

- \* When the control panel takes precedence, the external memory selection method cannot be selected.

# 6

## Liquid Crystal Display

### 6.1 General sequence of pages

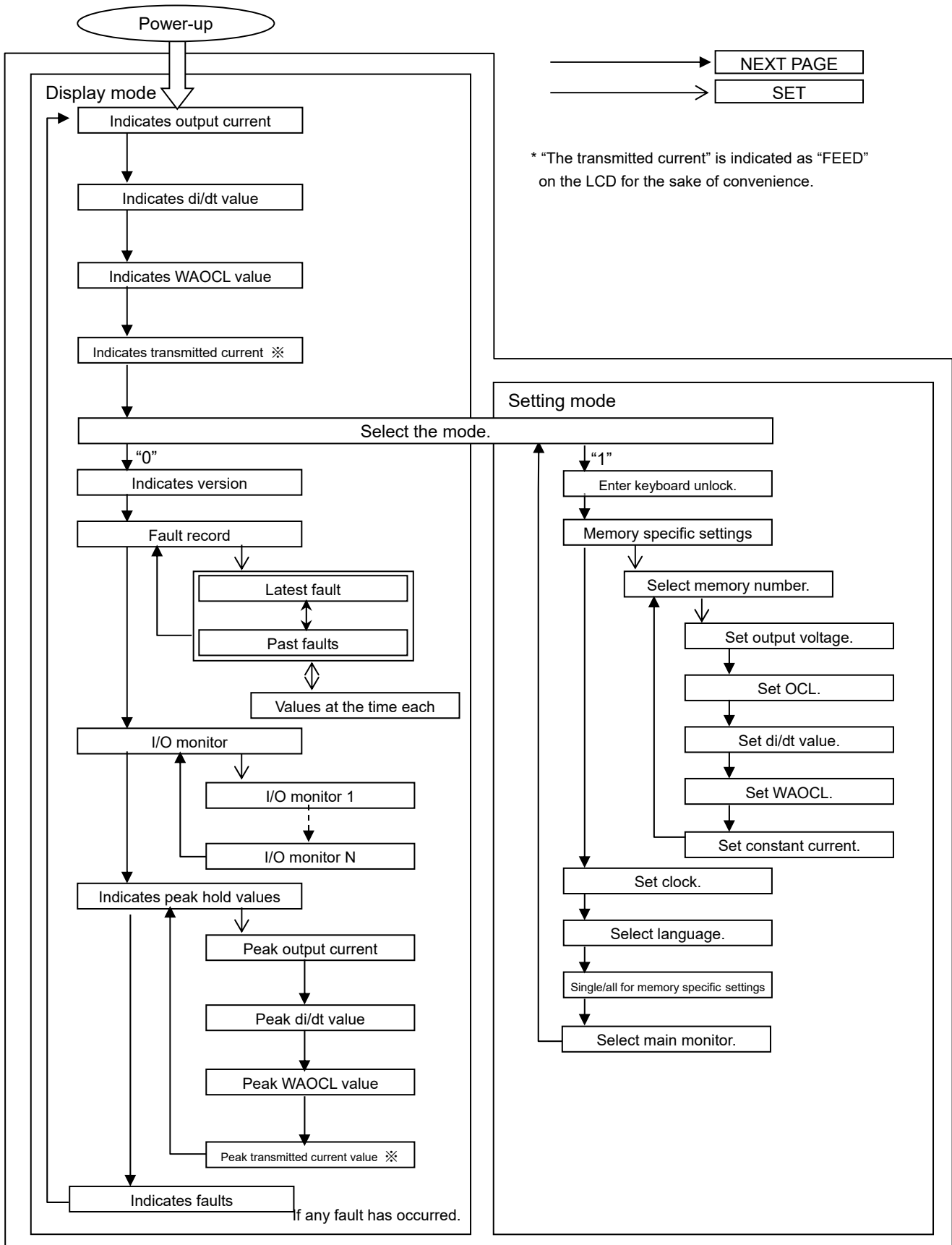

\* "The transmitted current" is indicated as "FEED" on the LCD for the sake of convenience.

## 6.2 Description of pages and bilingual indications

### 6.2.1 Display mode

No.	Japanese	English	Description																								
1.	BPS260 バージョン*. ** ***/**/** サクセイ	BPS260 Version*. ** write: **/**/****	The opening page of BPS260. Indicates the program version for about 3 seconds.																								
2.	Nox G1: xxxuA (xxxkV) P I G2: xxxuA (xxxkV) P	Nox G1: xxxuA (xxxkV) P I G2: xxxuA (xxxkV) P	The output current monitor page. Indicates the memory number, output current and set voltage.																								
3.	Nox G1: xxxuA (xxxkV) P d G2: xxxuA (xxxkV) P	Nox G1: xxxuA (xxxkV) P d G2: xxxuA (xxxkV) P	The output current variation monitor page. Indicates the memory number, output current variation and set voltage.																								
4.	Nox G1: xxxuA (xxxkV) P W G2: xxxuA (xxxkV) P	Nox G1: xxxuA (xxxkV) P W G2: xxxuA (xxxkV) P	The weighted average output current monitor screen. Indicates the memory number, weighted average output current and set voltage.																								
5.	Nox G1: x. xxA (xxxkV) P F G2: x. xxA (xxxkV) P	Nox G1: x. xxA (xxxkV) P F G2: x. xxA (xxxkV) P	The transmitted current monitor page. Indicates the memory number, transmitted current and set voltage.																								
6.	*モード* センタク 0 (ヒョウジ: 0 セツテイ: 1)	*MODE SELECT 0 (DISPLAY: 0 SET: 1)	The mode selection page. Select 1 and press "NEXT PAGE" to enter the setting mode.																								
7.	>イジ ヨウリレキ ヒョウジ (シヨウサイ ヒョウジ セット キー)	>FAULT RECORD (DETAILS SET KEY)	The fault record selection page. Press the SET key to view the fault record.																								
8.	>I/O モニタ ヒョウジ (シヨウサイ ヒョウジ セット キー)	>I/O MONITOR DISPLAY (DETAILS SET KEY)	The I/O monitor selection page. Press the SET key to view the I/O monitor.																								
9.	>ピーク ホールド (シヨウサイ ヒョウジ セット キー)	>PEAK HOLD (DETAILS SET KEY)	The peak hold selection page. Press the SET key to view the peak held values.																								
10.	>>Gx mm/dd hh:mm	>>Gx mm/dd hh:mm	The fault record page. Indicates past 100 faults in order from the latest one. Press the SET key to view detailed information at the time each fault occurred.																								
11.	OCL xxx uA (xxxkV)	OCL xxx uA (xxxkV)	Output overcurrent fault																								
12.	di/dt xx uA (xxxkV)	di/dt xx uA (xxxkV)	Output current variation fault																								
13.	WAOCL xx uA (xxxkV)	WAOCL xx uA (xxxkV)	Weighted average output current OCL fault																								
14.	ソウデン x. xx A (xxxkV)	FEED x. xx A (xxxkV)	Feed wire fault																								
15.	ソウデン オフ x. xx A (xxxkV)	FEEDoff x. xx A (xxxkV)	Feed wire fault (H.V. off-time)																								
16.	キカン xxx uA (xxxkV)	RETURN xxx uA (xxxkV)	Return wire fault																								
17.	キカン オフ xxx uA (xxxkV)	RTNoff xxx uA (xxxkV)	Return wire fault (H.V. off-time)																								
18.	H. V. xxx kV (xxxkV)	H. V. xxx kV (xxxkV)	H.V. output fault																								
19.	H. V. オフ xxx kV (xxxkV)	H. V. off xxx kV (xxxkV)	H.V. output fault (H.V. off-time)																								
20.	B ケン xx. x V (xxxkV)	Bsource xx. x V (xxxkV)	B source voltage fault																								
21.	トキ ヲ アワセテ クタサイ	Please set Clock	Clock fault																								
22.	インターロック	INTER LOCK	Interlocked																								
23.	ツウシン イジ ヨウ	COMM. FAULT	Communication fault																								
24.	xxxuA xxxkV x. xxA xxxuA xxxuA	xxxuA xxxkV x. xxA xxxuA xxxuA	Detailed information about each fault. Indicates the output current, set voltage, transmitted current, output current variation comparative value and weighted average at the time the fault occurred. Press the SET key to return to the fault record page.																								
25.	<イジ ヨウ リレキ クリア> クリア [SET] / チュウシ [NEXT]	<FAULT RECORD CLEAR> Init [SET] / Stop [NEXT]	The confirmation page for fault record clearing.																								
26.	>>I/O モニタ	>>I/O MONITOR																									
27.	ニユリヨク1 76543210	INPUT1 76543210	<table border="1"> <tr> <td>0</td> <td>1</td> <td>Remote signal for gun 1</td> </tr> <tr> <td>1</td> <td>2</td> <td>Paint signal for gun 1</td> </tr> <tr> <td>2</td> <td>3</td> <td>External memory setting 1 for gun 1</td> </tr> <tr> <td>3</td> <td>4</td> <td>External memory setting 2 for gun 1</td> </tr> <tr> <td>4</td> <td>5</td> <td>External memory setting 3 for gun 1</td> </tr> <tr> <td>5</td> <td>6</td> <td>Interlocked</td> </tr> <tr> <td>6</td> <td>7</td> <td>Remote signal for gun 2</td> </tr> <tr> <td>7</td> <td>8</td> <td>Paint signal for gun 2</td> </tr> </table>	0	1	Remote signal for gun 1	1	2	Paint signal for gun 1	2	3	External memory setting 1 for gun 1	3	4	External memory setting 2 for gun 1	4	5	External memory setting 3 for gun 1	5	6	Interlocked	6	7	Remote signal for gun 2	7	8	Paint signal for gun 2
0	1	Remote signal for gun 1																									
1	2	Paint signal for gun 1																									
2	3	External memory setting 1 for gun 1																									
3	4	External memory setting 2 for gun 1																									
4	5	External memory setting 3 for gun 1																									
5	6	Interlocked																									
6	7	Remote signal for gun 2																									
7	8	Paint signal for gun 2																									

No.	Japanese	English	Description
28.	エユリヨク 2 3210	INPUT2 3210	0 9 External memory setting 1 for gun 2
			1 10 External memory setting 2 for gun 2
			2 11 External memory setting 3 for gun 2
			3 12 Reset
29.	キ-スイッチ 1 76543210	KEYSWITCH1 76543210	0 1 Reserved
			1 2 Reserved
			2 3 Reserved
			3 4 Reserved
			4 5 Reserved
			5 6 Δ
			6
			7
30.	キ-スイッチ 2 76543210	KEYSWITCH2 76543210	0 7 RESET
			1 8 Reserved
			2 9 SET
			3 10 NEXT PAGE
			4 11 SHIFT
			5 12 ▽
31.	DIPSW 76543210	DIPSW 76543210	0 1 Model selection (BPS260: OFF)
			1 2 WB mode switching (BPS260: OFF)
			2 3 Reserved
			3 4 Reserved
			4
			5
			6
			7
32.	シュツリヨク 76543210	OUTPUT 76543210	0 1 H.V. 1
			1 2 Fault 1
			2 3 Reserved
			3 4 H.V. 2
			4 5 Fault 2
			5 6 Reserved
			6 - H.V. output 1
			7 - H.V. output 2
33.	LCD デ-タ 76543210	LCD DATA 76543210	
34.	LCD コントロ-ル 76543210	LCD CONT. 76543210	
35.	A/D1 xxxx mV	A/D1 xxxx mV	Output current of gun 1
36.	A/D2 xxxx mV	A/D2 xxxx mV	Output current of gun 2
37.	A/D3 xxxx mV	A/D3 xxxx mV	Not used
38.	A/D4 xxxx mV	A/D4 xxxx mV	Not used
39.	A/D5 xxxx mV	A/D5 xxxx mV	Current transmitted to gun 1
40.	A/D6 xxxx mV	A/D6 xxxx mV	Current transmitted to gun 2
41.	A/D7 xxxx mV	A/D7 xxxx mV	Not used
42.	A/D8 xxxx mV	A/D8 xxxx mV	B source voltage to gun 1
43.	A/D9 xxxx mV	A/D9 xxxx mV	B source voltage to gun 2
44.	D/A1 xxxx mV	D/A1 xxxx mV	Set voltage of gun 1
45.	D/A2 xxxx mV	D/A2 xxxx mV	Set voltage of gun 2
46.	D/A3 xxxx mV	D/A3 xxxx mV	Not used
47.	D/A4 xxxx mV	D/A4 xxxx mV	Not used
48.	バックライト タイマ xxxxxxms	Back Light xxxxxxms	Backlight timer
49.	カタシキ x	MODEL x	Model: 0 for BPS260, 1 for BPS290
50.	COM R:0xxx S:0xxx	COM R:0xxx S:0xxx	Communication

No.	Japanese	English	Description
51.	G1 カト <sup>°</sup> うxxxxxxHxxMxxS	G1 WORKxxxxxxHxxMxxS	Cumulative H.V. on-time for gun 1
52.	G2 カト <sup>°</sup> うxxxxxxHxxMxxS	G2 WORKxxxxxxHxxMxxS	Cumulative H.V. on-time for gun 2
53.	>>ピークホルト <sup>°</sup>	>>PEAK HOLD	
54.	G1 I: (xxx) xxx uA	G1 I: (xxx) xxx uA	Peak output current of gun 1. Clearable with $\Delta/\nabla$ .
55.	G1 d: (xxx) xxx uA	G1 d: (xxx) xxx uA	Peak output current variation of gun 1. Clearable with $\Delta/\nabla$ .
56.	G1 W: (xxx) xxx uA	G1 W: (xxx) xxx uA	Peak weighted average output current of gun 1. Clearable with $\Delta/\nabla$ .
57.	G1 F: (x. xx) x. xx A	G1 F: (x. xx) x. xx A	Peak transmitted current to gun 1. Clearable with $\Delta/\nabla$ .
58.	G2 I: (xxx) xxx uA	G2 I: (xxx) xxx uA	Peak output current of gun 2. Clearable with $\Delta/\nabla$ .
59.	G2 d: (xxx) xxx uA	G2 d: (xxx) xxx uA	Peak output current variation of gun 2. Clearable with $\Delta/\nabla$ .
60.	G2 W: (xxx) xxx uA	G2 W: (xxx) xxx uA	Peak weighted average output current of gun 2. Clearable with $\Delta/\nabla$ .
61.	G2 F: (x. xx) x. xx A	G2 F: (x. xx) x. xx A	Peak transmitted current to gun 2. Clearable with $\Delta/\nabla$ .

### 6.2.2 Fault pages

No.	Japanese	English	Description
1.	#Nox Gx OCL xxx uA (xxxkV)	#Nox Gx OCL xxx uA (xxxkV)	Output overcurrent fault
2.	#Nox Gx di/dt xx uA (xxxkV)	#Nox Gx di/dt xx uA (xxxkV)	Output current variation fault
3.	#Nox Gx WAOCL xx uA (xxxkV)	#Nox Gx WAOCL xx uA (xxxkV)	Weighted average output current OCL
4.	#Nox Gx ソウデン x. xx A (xxxkV)	#Nox Gx FEED x. xx A (xxxkV)	Feed wire fault
5.	#Nox Gx ソウデンオフ x. xx A (xxxkV)	#Nox Gx FEEDoff x. xx A (xxxkV)	Feed wire fault (H.V. off-time)
6.	#Nox Gx キカン xxx uA (xxxkV)	#Nox Gx RETURN xxx uA (xxxkV)	Return wire fault
7.	#Nox Gx キカンオフ xxx uA (xxxkV)	#Nox Gx RTNoff xxx uA (xxxkV)	Return wire fault (H.V. off-time)
8.	#Nox Gx H. V. xxx kV (xxxkV)	#Nox Gx H. V. xxx kV (xxxkV)	H.V. output fault
9.	#Nox Gx H. V. オフ xxx kV (xxxkV)	#Nox Gx H. V. off xxx kV (xxxkV)	H.V. output fault (H.V. off-time)
10.	#Nox Gx Bケン xx. x V (xxxkV)	#Nox Gx B SOURCE xx. x V (xxxkV)	B source voltage fault
11.	#E2 データフラッシュ ショキカ	#E2 DATA Flash CLEAR	E2 Data flash initialized
12.	#トクイヲアワセテクダサイ	#Please set Clock	Clock fault
13.	#インターロック	#INTER LOCK	Interlock input
14.	#ツウシイジヨウ	#COMM. FAULT	Communication fault
15.	#ウォッチドッグ タイムアウト	#WatchDog TimeOut	Program uncontrollable
16.	#	#	No fault

### 6.2.3 Setting mode

No.	Japanese	English	Description
1.	>メモリ へツ セッテイ (シヨウサイ ヒヨウジ セット キー) x	>MEMORY SETUP (DETAILS SET KEY)	The memory specific setting selection page. Press the "SET" key to open the setting page.
2.	>トケイ mm/dd hh:mm:ss 20yy/mm/dd hh:mm:ss	CLOCK mm/dd hh:mm:ss 20yy/mm/dd hh:mm:ss	Set the clock. The page opening time is indicated on the upper line.
3.	>バ イリンガール (ニホンゴ :0/ENGLISH:1) x	>BILINGUAL (ニホンゴ :0/ENGLISH:1) x	Select the language used on the liquid crystal display.
4.	>メモリ へツ セッテイ レントウ (コベツ:0/レントウ:1) x	>SETTING (Single:0/All:1) x	Choose to enter memory specific settings for each gun or use common settings.
5.	>メイン ガメン セッテイ (I, d, W, F:0-3) x	>Main MONITER (I, d, W, F:0-3) x	Enter main monitor page settings.
6.	>ハンメン ソウサ キンシ x x x x	>KEY LOCK x x x x	Lock or unlock the keyboard.
7.	>>メモリ No. No. x	>>MEMORY No. No. x	The memory number selection page for memory specific settings. Select a memory number using "△/▽" and press "SET" to proceed to the parameter setting pages.
8.	>>>セッテイ テンアツ No. x Gx:xxx kV	>>>H. V. SET No. x Gx:xxx kV	The memory specific output voltage setting page.
9.	>>>OCL No. x Gx:xxx uA	>>>OCL No. x Gx:xxx uA	The memory specific OCL threshold setting page.
10.	>>>di/dt No. x Gx: xx uA	>>>di/dt No. x Gx: xx uA	The memory specific di/dt threshold setting page.
11.	>>>WAOCL No. x Gx: xx uA	>>>WAOCL No. x Gx: xx uA	The memory specific WAOCL threshold setting page.
12.	>>>テイデ んリユウ No. x Gx:xxx uA	>>>Const. Curr. No. x Gx:xxx uA	The memory specific constant current setting page.
13.	ハンメン ソウサ キンシ セッテイ x x x x	KEY LOCK x x x x	The keyboard has been locked.
14.	ハンメン ソウサ キンシ カイジ ョ x x x x	KEY LOCK RELEASE x x x x	The keyboard has been unlocked.
15.	ハンメン ソウサ キンシチュウテ ス	KEY OPERATION PROHIBITION	The keyboard is being locked. (Setting change and memory selection are prohibited.)
16.	パスワード ガ チカ イマス	PASSWORD NG	The password is wrong.

### 6.3 Transitions among pages

- Upon the power-up, the program version is indicated for 3 seconds. Then, the output current monitor page opens.
- If no manual input is made to any page for 60 seconds, the backlight turns off and the display returns to the main monitor page.
  - \* Except when a fault record, I/O monitor or clock page is shown or the selected model is wrong.
- Press the “RESET” key to return to the main monitor page.
  - \* Except when the equipment is interlocked or the clock page is shown.
- Press “SHIFT” and “NEXT PAGE” at the same time to return to the previous page.

#### 6.3.1 View mode

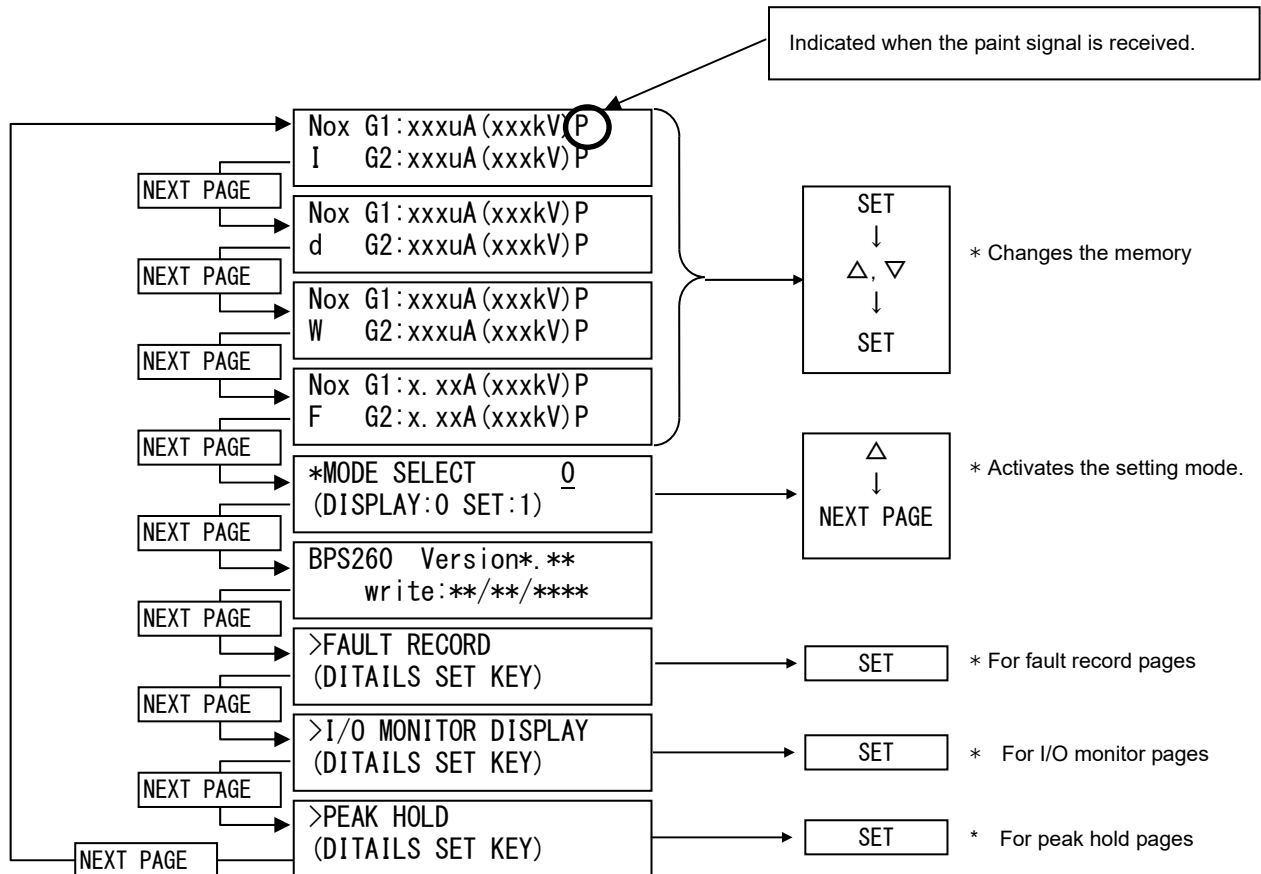

### 6.3.2 I/O monitor pages

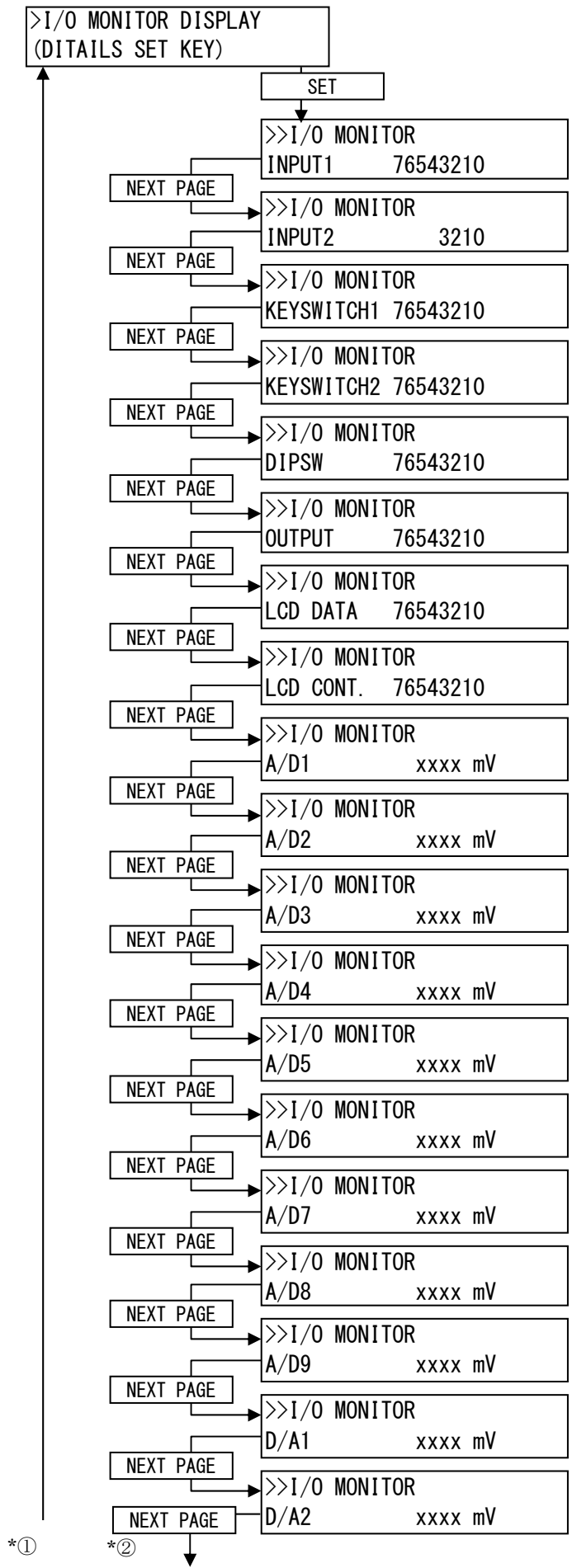

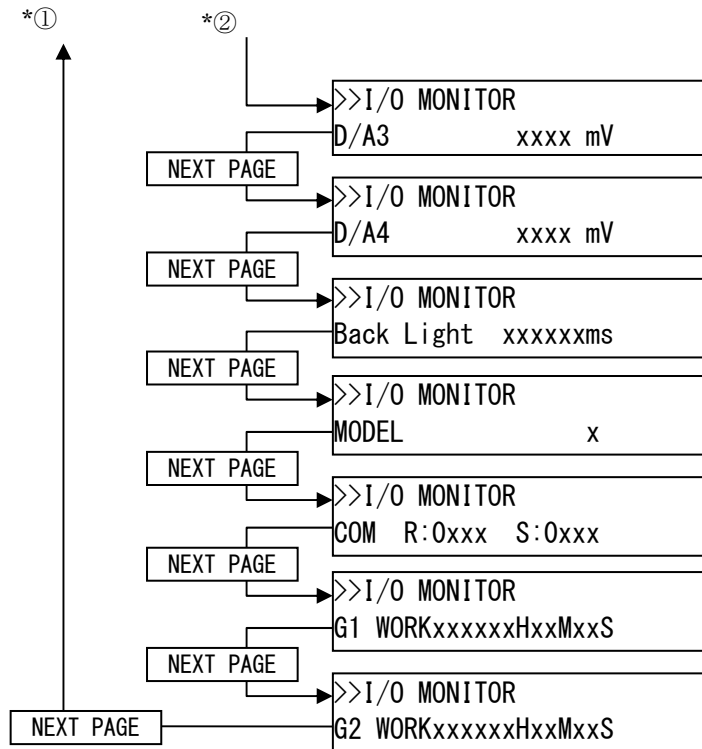

\* Keep pressing the “SHIFT” key on each screen to clear cummlative operation time.

### 6.3.3 Peak hold pages

- The peak hold pages indicate peak values of the output current, output current variation and weighted average output current of and transmitted current to each gun.  
( ) Inside is a value except dull time.
- The peak values can be reset using “ $\Delta$  and  $\nabla$ ”(Only indicated values).
- \* Keep pressing the “SHIFT” key to clear all of the peak hold values.

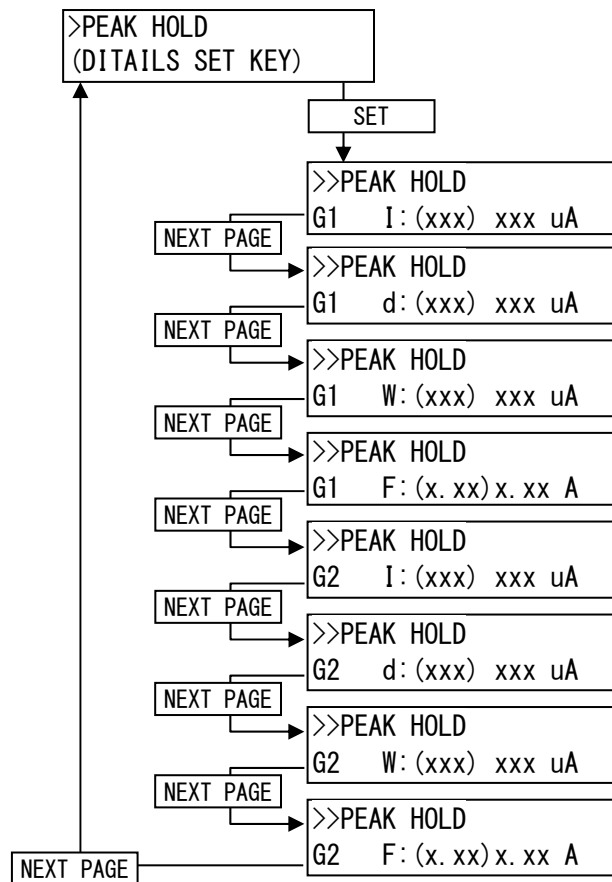

### 6.3.4 Fault record pages

- A fault record page opens if any fault occurs.
- Press “△” or “▽” to view the simultaneously pending faults.
- Press “NEXT PAGE” to open the output current monitor page. Press “NEXT PAGE” on the peak hold selection page to return to the fault record page.
- Press the “RESET” key or turn on the “RESET” signal to release the fault and return to the main monitor page except when the equipment is interlocked. \*The clock page will not change.
- When the equipment is interlocked, turn off the interlock signal to release the fault and shift to the main monitor page.

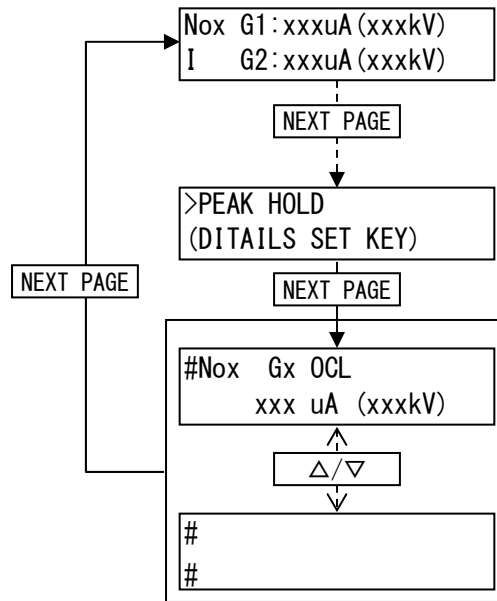

### 6.3.5 Setting mode

- Press “△ or ▽” to increase or decrease the setting value.
- Press “△ or ▽” for 5 seconds or longer to increase or decrease it by 10.
- Press “SHIFT” to move the cursor.

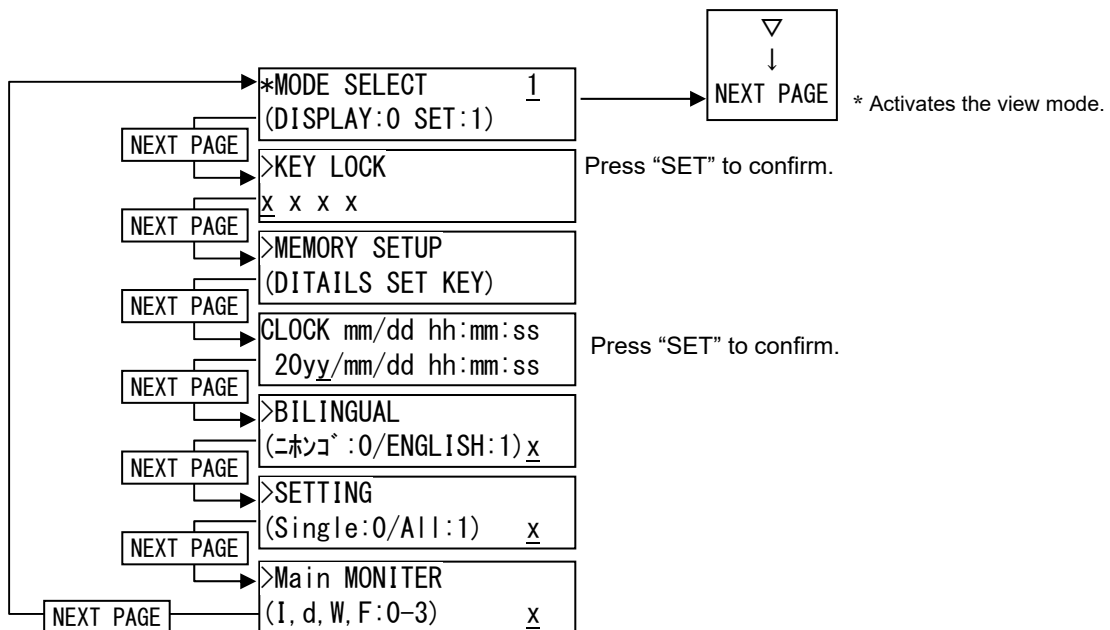

### 6.3.6 Memory specific settings

- Press “ $\Delta$  or  $\nabla$ ” to increase or decrease the setting value.
- Press “ $\Delta$  or  $\nabla$ ” for 5 seconds or longer to increase or decrease it by 10.

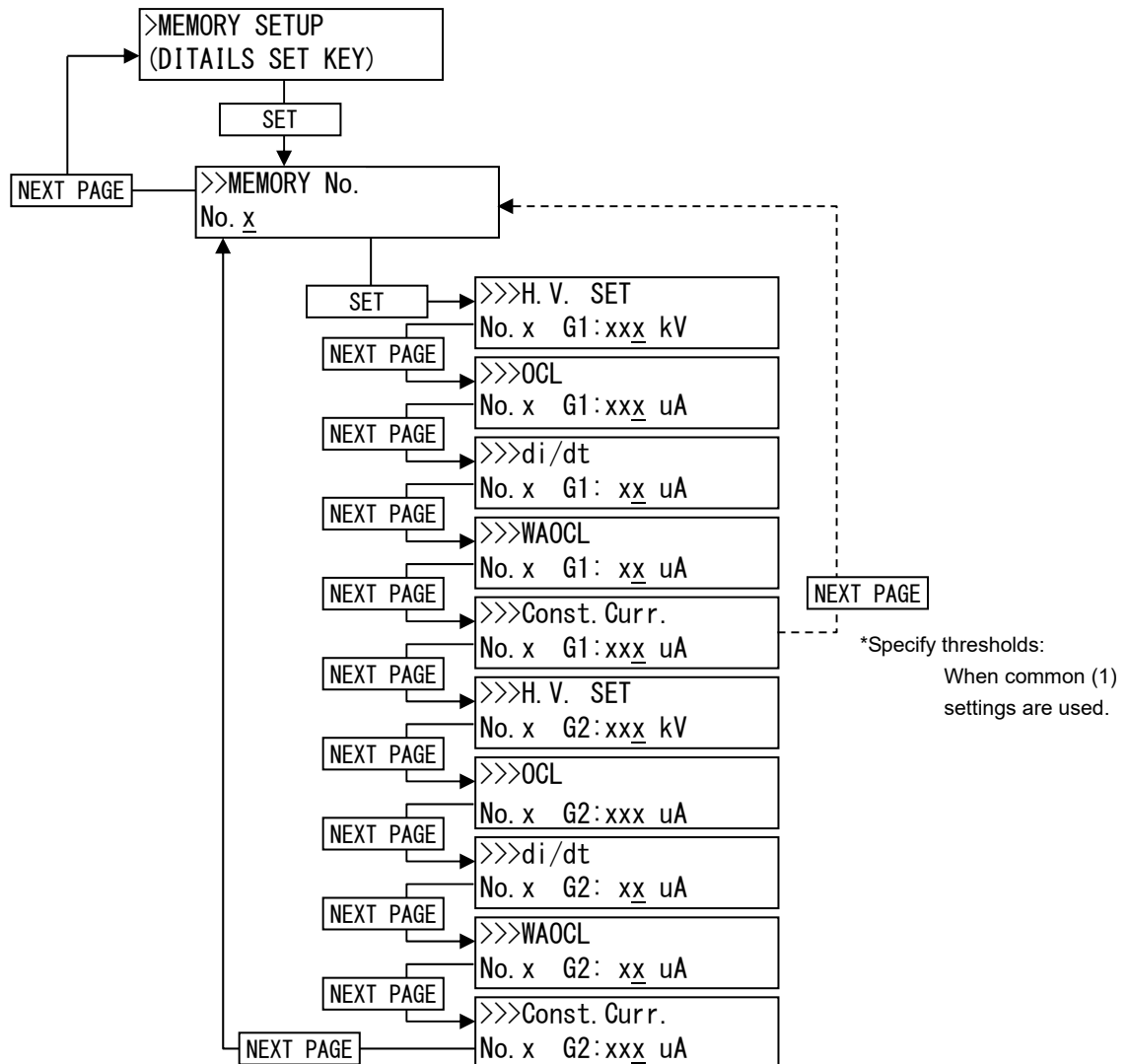

\*No.8 is indicated only when communication is available. The set voltage and constant current thresholds of No.8 cannot be changed on the keyboard.

## 7.1 Classification of faults

Fault type	Detailed description	Probable cause	Remedy
Output overcurrent fault (OCL) "#Nox Gx OCL xxx uA (xxxkV)"	When the output current exceeds the memory-specific OCL detection value (OCL detection value during communication when communication is in use)	(1) Approach of the gun and ground (2) Dirt inside and outside the gun (3) Condensation on the gun (4) Water intrusion into the air path. (5) Low paint resistance (6) Metal bridge (7) Faulty gun	(1) Increase the spraying distance. (2) Wash the gun. (3) Dry the gun. (4) Drain water in the air path. (5) Adjust the resistance of the paint. (6) Wash the paint path. Decrease the set voltage. (7) Replace the gun.
Output current change fault (di/dt) "#Nox Gx di/dt xx uA (xxxkV)"	When the output current variation exceeds the memory-specific di/dt detection value (di/dt detection value during communication when communication is in use)	(1) Rapid approach of the gun and ground (2) Wobble of the product to be coated (3) Water intrusion into the air path	(1) Increase the spraying distance. (2) Improve the wobble of the product to be coated. (3) Drain water in the air path.
Weighted average OCL fault (WAOCL) "#Nox Gx WAOCL xx uA (xxxkV)"	When the difference between the output current and the output current weighted average exceeds the memory-specific WAOCL detection value (WAOCL detecton value during communication when communication is in use), which results in increase in output current	(1) Rapid approach of the gun and ground (2) Wobble of the product to be coated (3) Water intrusion into the air path	(1) Increase the spraying distance. (2) Improve the wobble of the product to be coated. (3) Drain water in the air path.
Electric line fault "#Nox Gx FEED x. xx A (xxxkV)"	When the transmission current exceeds or drops below the electric line fault detection value	(1) Improper connection of the connection cable (2) Open circuit of the connection cable (3) Faulty gun	(1) Reconnect the connection cable. (2) Replace the connection cable. (3) Replace the gun.
Feedback current line fault "#Nox Gx RETURN xxx uA (xxxkV)"	When the output current drops below the feedback current line fault detection value	(1) Damaged or dirty charge electrode (2) Improper connection of the connection cable (3) Open circuit of the connection cable (4) The paint resistance is high, and the set voltage is low. (5) Faulty gun	(1) Replace or wash the charge electrode. (2) Reconnect the connection cable. (3) Replace the connection cable. (4) Adjust the resistance of the paint. Increase the set voltage. (5) Replace the gun.
Feedback current line fault (High voltage OFF) "#Nox Gx RTNoff xxx uA (xxxkV)"	When output current is detected with high voltage turned off	(1) The distance to a neighboring gun is small.	(1) Increase the distance between the guns.
Interlock "#INTER LOCK"	When an interlock signal is input	(1) External device fault	(1) Reconnect and check the external device.
Clock fault "#Please set Clock"	When oscillation stop of the clock IC is detected during activation	(1) Long term power-off	(1) Set the time.

For clock fault , no error is output. No error lamp is lit.

If you cannot restore the device with the above remedy, contact us.

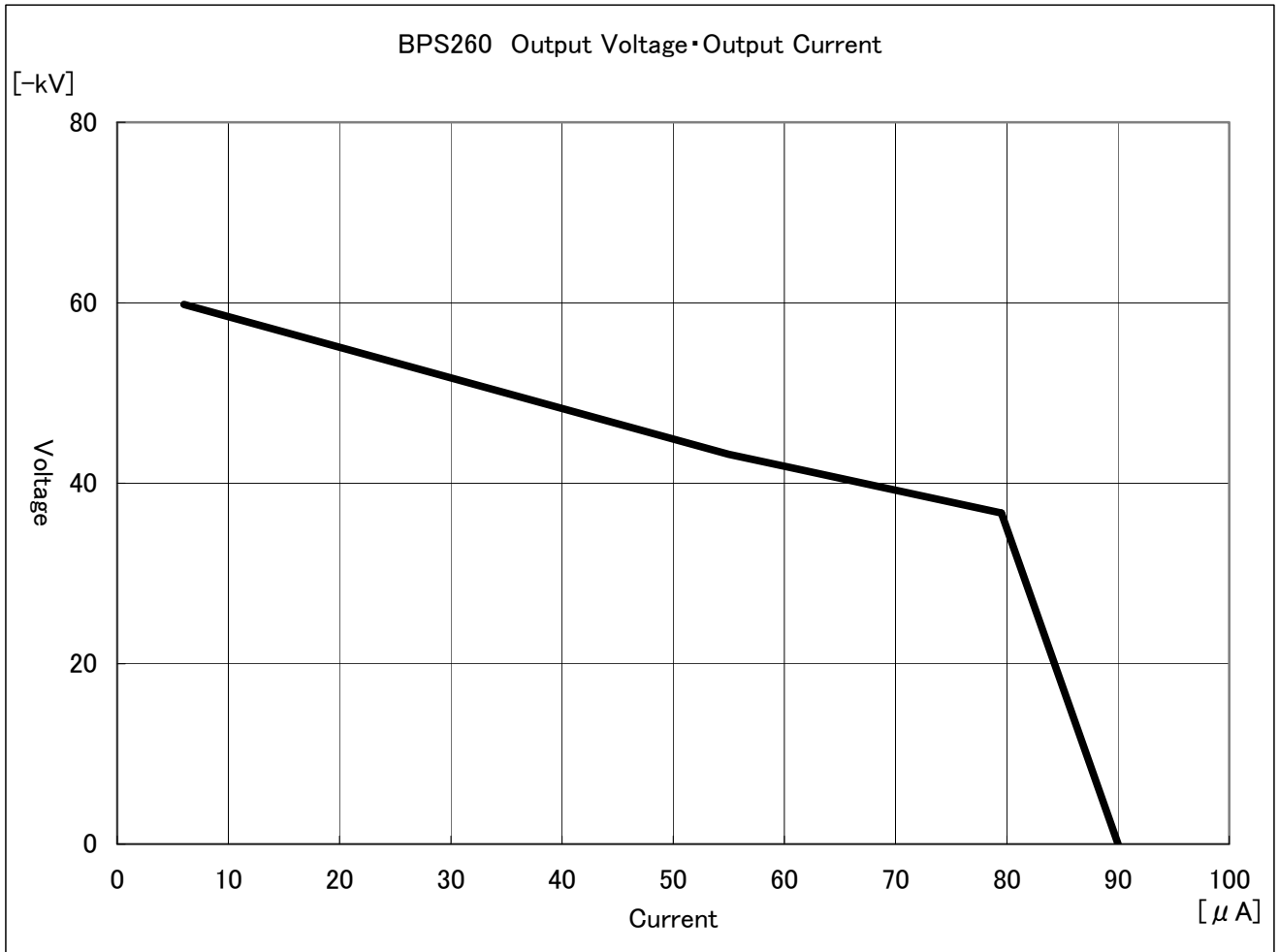

### 9.1 Fault record

The fault record can be viewed by opening a fault record page in view mode.

The fault record page contains information such as gun number, fault occurrence date/time (the year and seconds are not shown), fault type, thresholds and selected output voltage. Data on the latest fault is shown first. Data on up to 100 faults from the latest one is saved. Press “△” to view older faults or “▽” to view newer ones. Keep pressing the “SHIFT” key to open the fault record clearing page.

Press the “SET” key on this page to clear the fault record.

Press “SET” on a fault record page displays values of the output current, output voltage(0 kV), transmitted current, di/dt increment and weighted average increment at the time the fault occurred.

\*It can be set on the Interlock fault record setting page, whether to maintain the interlock record.

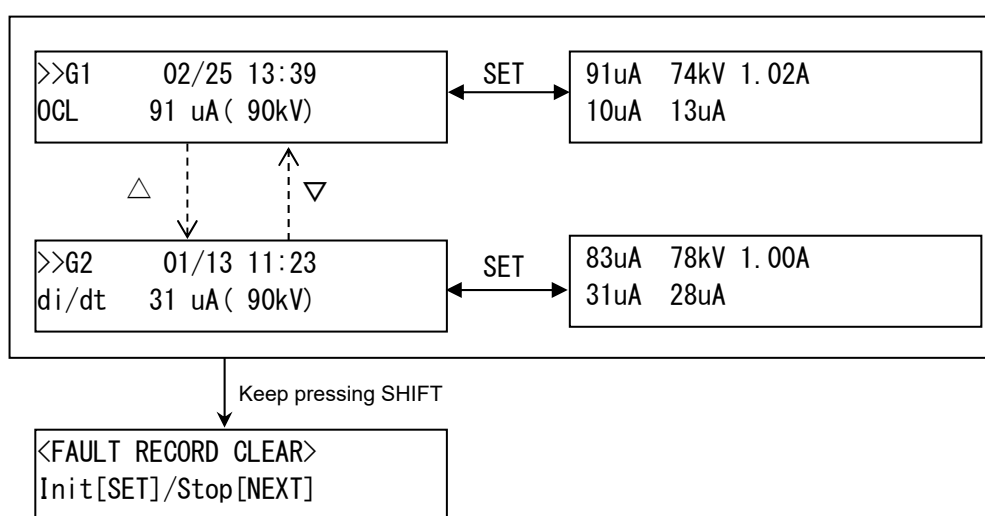

### 9.2 Setting the clock

To view the correct time on the fault record pages, never fail to set the clock.

The clock fault page opens if a clock fault is detected upon the power-up and any of the following conditions is met.

- The dipswitch setting is consistent with the model saved in the E2 Data flash initialized.

**If the controller is left with the power switch off for an extended period, a clock fault occurs.**

**Set the clock before restarting.**

The clock setting page can be opened by pressing “SET” on the mode selection page.

```

CLOCK mm/dd hh:mm:ss
20yy/mm/dd hh:mm:ss
  
```

- ① Press “SHIFT” to move the cursor.
- ② Press “△” or “▽” to increase or decrease the value.
- ③ Press “SET” to confirm the time.

**Once the clock is correctly set, the time taken from the clock, which is shown on the upper line, changes to be equivalent to the clock setting time shown on the lower line.**

### 9.3 Keyboard locking function

- Keyboard operations such as setting change and memory selection can be prohibited by entering the password “0001” on the keyboard locking page. To unlock, enter “0002” on the password page.
- When the “KEY LOCK” is set to 0, the controller starts with the keyboard locked upon the power-up. If you want to change a setting, unlock the keyboard. The keyboard is locked again when the locking operation is performed again or the backlight turns off (no manual input is made for 60 seconds) (the backlight does not turn off when a fault or I/O monitor page is shown).
- When the “KEY LOCK” is set to 1, the keyboard is locked/released each entry of the password. The controller starts with the keyboard kept its previous status.

KEY LOCK 0 0 0 1
KEY LOCK RELEASE 0 0 0 2
KEY OPERATION PROHIBITION

- \* If a setting or memory is changed while the keyboard is locked, an error page opens. Press any key to return to the main monitor page.

>KEY LOCK FUNCTION  <u>X</u>
------------------------------------

## 10.1 Memory specific settings

No.	Setting item	Unit	Default	Max.	Min.	Resolution
1.	Set output voltage	kV	*30 60	*30 60	*10 20	1
2.	OCL threshold	μA	80	80	30	1
3.	Di/dt threshold	μA	20	25	2	1
4.	WAOCL threshold	μA	30	40	2	1
5.	Constant current	μA	80	80	25	1

\*When WB mode ON

Item No.	Set output voltage [kV]	OCL threshold [μA]	Di/dt threshold [μA]	WAOCL threshold [μA]	Constant current [μA]
1					
2					
3					
4					
5					
6					
7					
8 *	—				—

\* Memory No. 8 is only available when the optional serial gateway is used.

## 10.2 Setting mode

No.	Setting item	Unit	Default	Max.	Min.	Setting
1.	Clock setting	Yr	2001	2099	2000	
		Mo	1	12	1	
		Day	1	31	1	
		Hr	1	23	0	
		Min	1	59	0	
		Sec	1	59	0	
2.	Language (0 for Japanese or 1 for English)		0	1	0	
3.	Single or all for memory specific settings (0 for single or 1 for all)		1	1	0	
4.	Main monitor settings		0	3	0	
	Output current monitor :0					
	Di/dt monitor :1					
	WAOCL monitor :2					
	Transmitted current monitor :3					

# 11

## Wiring

### 11.1 Outside dimensions

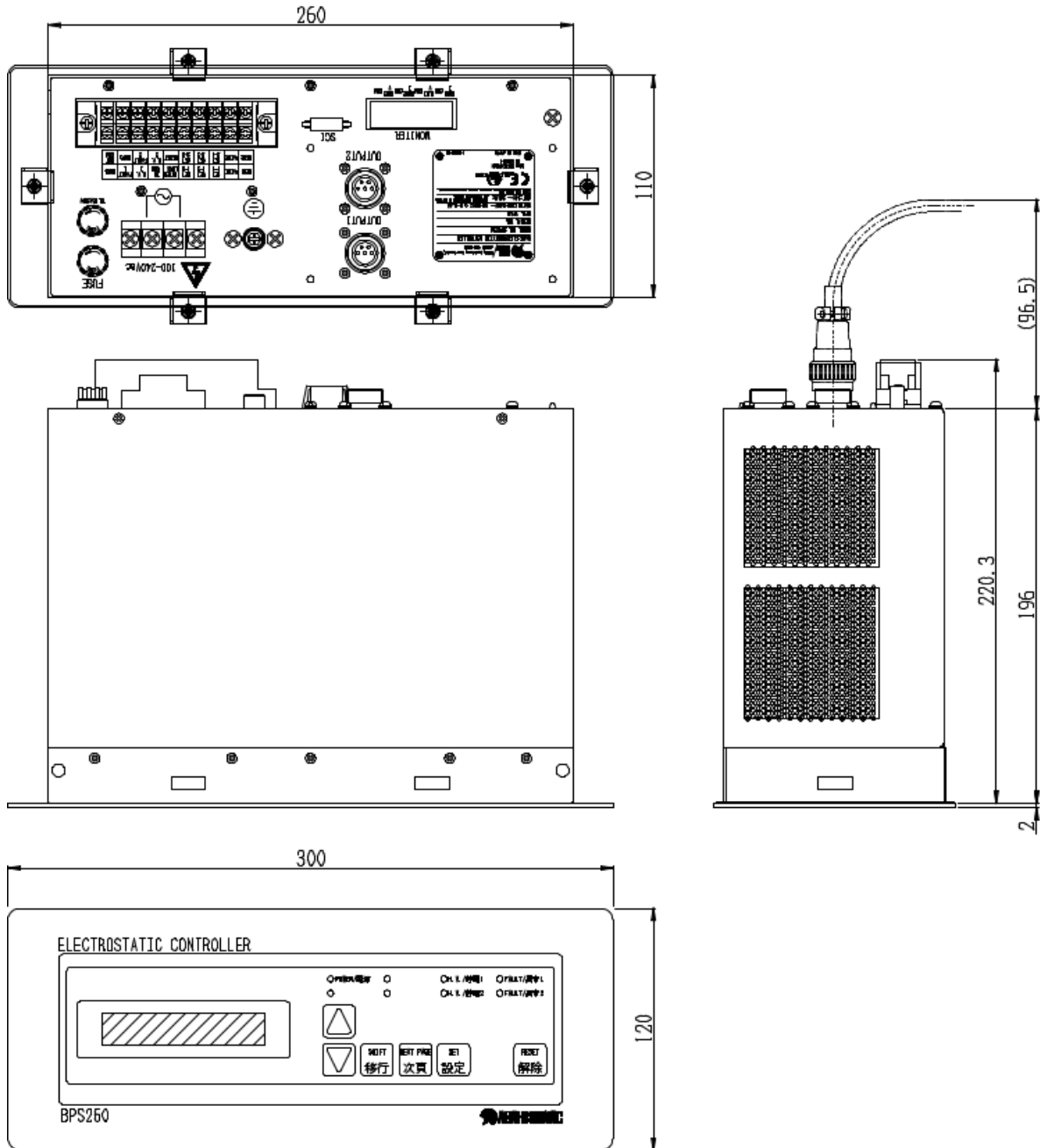

## 11.2 Names and functions of components

### 11.2.1 Names of components

<Back panel>

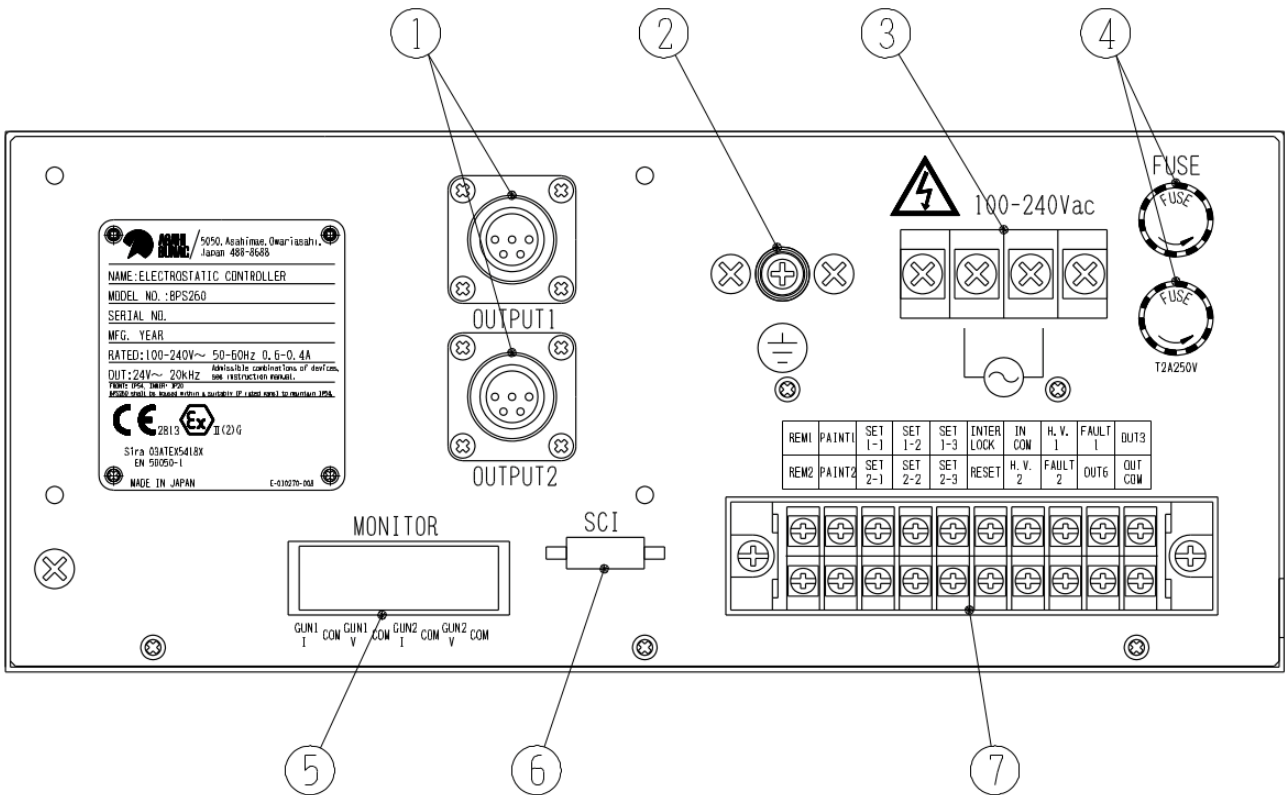

No.	Name	No.	Name
①	Output connectors "OUTPUT1" (for gun 1) "OUTPUT2" (for gun 2)	②	Grounding terminal "⊕"
③	Input power terminal block "~"	④	Fuse holder "FUUSE"
⑤	Output voltage/current monitor terminal block "MONITOR"	⑥	Communication connector "SCI"
⑦	I/O terminal block		

**Note:** The controller shape and specifications may be changed without notice to reflect improvements, etc.

<Side panel>

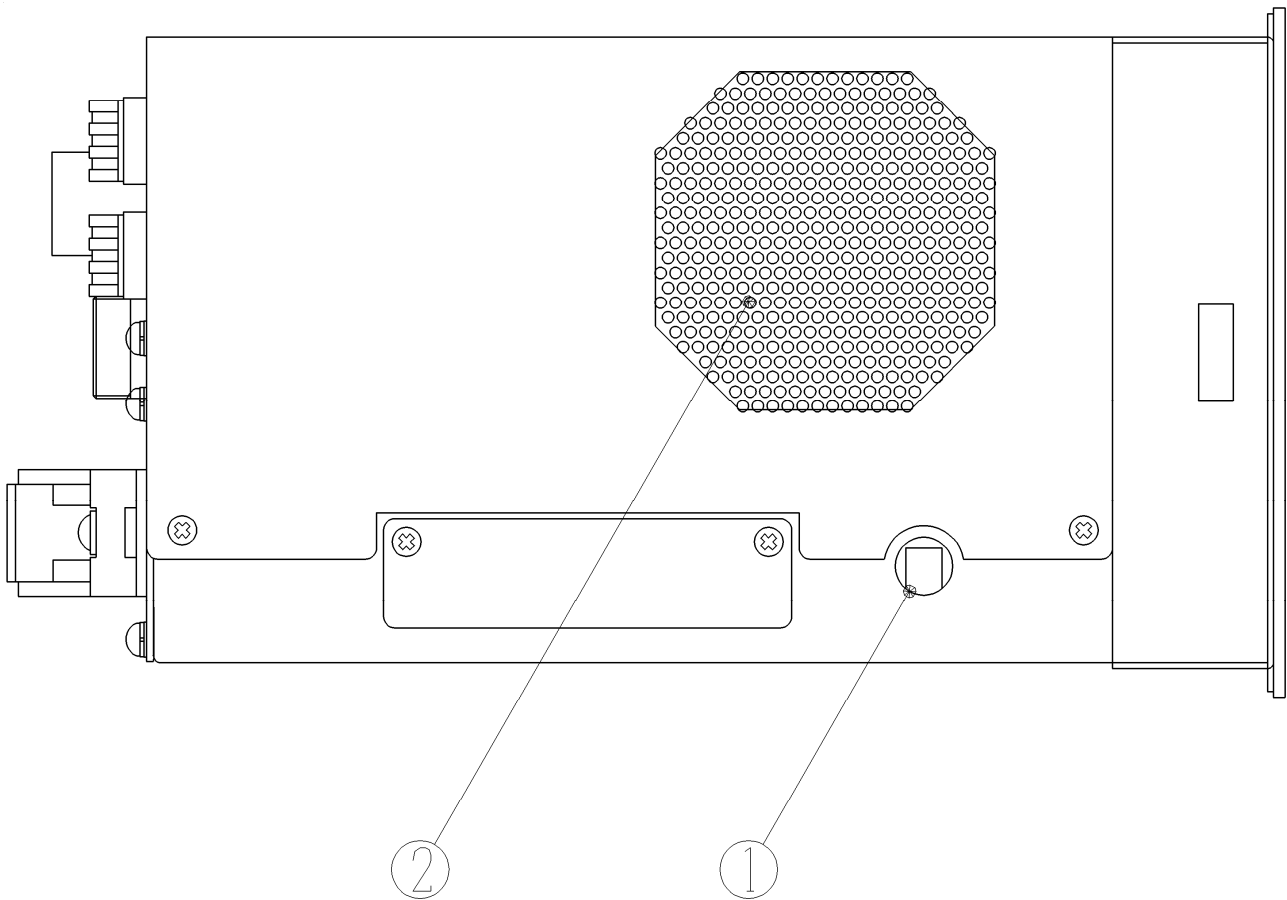

No.	Name	No.	Name
①	LCD contrast adjuster	②	Fan

<Rating Plate>

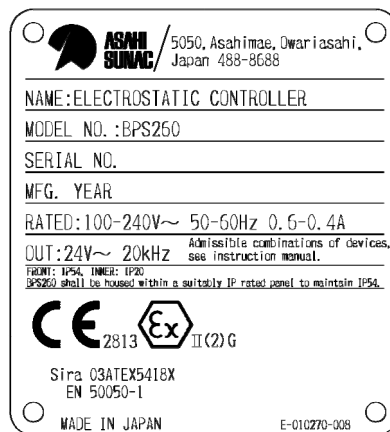

11.2.2 Functions of components

<Back panel>

- ① Output connectors “OUTPUT1” and “OUTPUT2”  
Connect the electrostatic gun feed cables. Use exclusive ones.

② Protective earth terminal “  ”

The protective earth terminal of the BPS260. The controller is Class I equipment. The controller uses a high voltage and shall be grounded with class D grounding work (100Ω or less). (Small, round) screw with spring and washer, M5 x 8L

 **WARNING**

**Incomplete grounding may lead to a failure, electric shock, injury, fire and/or explosion.**

③ Input power terminal block “  ”

A terminal block for input power. Supply 100 to 240VAC power. Using a power supply other than setting may lead to a failure and/or fire. Wire BPS290 separately from other equipments, and install appropriate circuit breaker, respectively. The power supply requires 20 A Branch Circuit Protection. (Small, round) screw with washer, M5 x 8L

 **WARNING**

**Using a power supply other than setting may lead to a failure and/or fire.**

 **WARNING**



**Touching the terminal block when it is alive, may lead to electric shock.**

④ Fuse holder “FUSE”

A3.15A (T3.15A250V) glass tube fuse has been inserted into each line. If the fuse is blown, do not turn on the power switch until the cause is located.

⑤ Output voltage/current monitor terminal block “MONITOR”

The output voltage and current of each electrostatic gun can be monitored as analog outputs between 0V and 5V. The output voltage is monitored as 2V at -100kV and the output current monitored as 2V at +/-100μA.

<Applicable wire sizes and strip lengths>

Rated wire sizes	φ1.2mm (AWG16) or larger for single wires, 1.25mm <sup>2</sup> (AWG16) or larger with φ0.18 or larger cores for twist wires
Usable wire sizes	Single wires: φ0.4mm (AWG26) to φ1.2mm (AWG16) Twist wires: 0.2mm <sup>2</sup> (AWG24) to 1.25mm <sup>2</sup> (AWG16) with φ0.18 or larger cores
Standard strip length	11mm

<Layout on terminal block>

1	2	3	4	5	6	7	8
GUN1-I	COM	GUN1-V	COM	GUN2-I	COM	GUN2-V	COM

<Designations and details>

Code	Designation	Details
GUN1-I	External output current monitor for gun 1	0 to 5V output, 2V at 100μA
GUN1-V	External output voltage monitor for gun 1	0 to 5V output, 2V at -100kV
GUN2-I	External output current monitor for gun 2	0 to 5V output, 2V at 100μA
GUN2-V	External output voltage monitor for gun 2	0 to 5V output, 2V at -100kV

⑥ Communication connector “SCI”

⑦ I/O terminal block

Cross-recessed head screw with square washer, M3

<Input circuit>

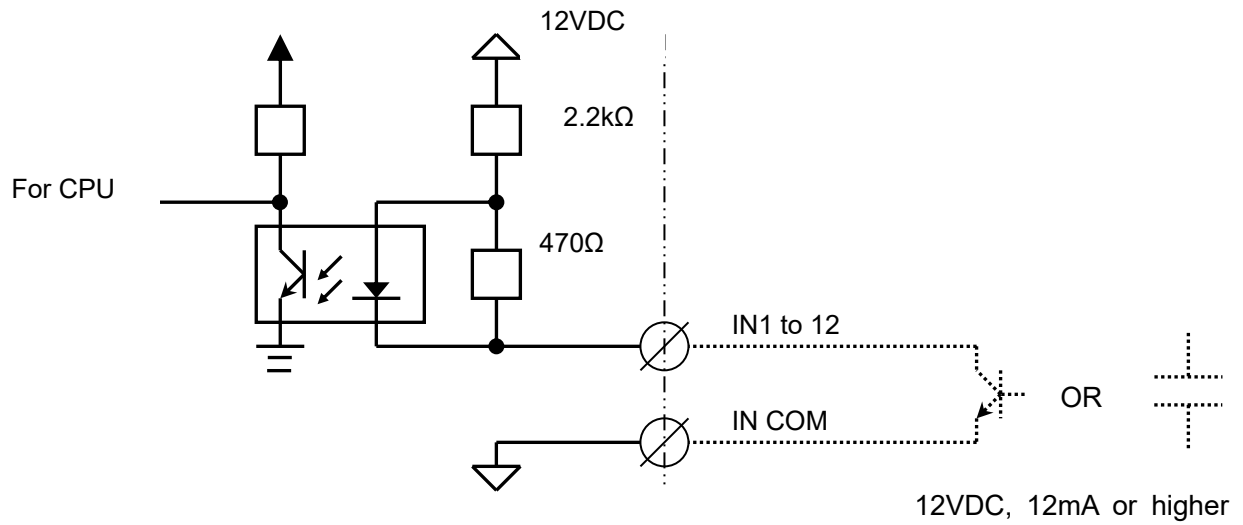

<Output circuit>

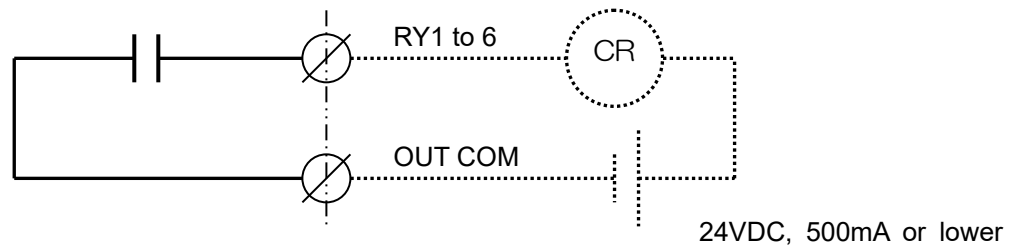

<Layout on terminal block>

A1	A2	A3	A4	A5	A6	A7	A8	A9	A10
REM1	PAINT 1	SET 1-1	SET 1-2	SET 1-3	INTER LOCK	IN COM	H.V. 1	FAULT 1	OUT3
B1	B2	B3	B4	B5	B6	B7	B8	B9	B10
REM2	PAINT 2	SET 2-1	SET 2-2	SET 2-3	RESET	H.V. 2	FAULT 2	OUT6	OUT COM

※Do not use No.OUT3 and No.OUT6.

<Designations and details>

1) Inputs

Code	No. on terminal block	Designation	Details
REM1	A1	Remote ON signal for gun 1	Remote signal IN for gun 1
PAINT1	A2	Paint ON signal for gun 1	Paint signal IN for gun 1
SET1-1	A3	External memory selection 1 for gun 1	Memory selection signal IN, bit 1 for gun 1
SET1-2	A4	External memory selection 2 for gun 1	Memory selection signal IN, bit 2 for gun 1
SET1-3	A5	External memory selection 3 for gun 1	Memory selection signal IN, bit 3 for gun 1
INTER LOCK	A6	Interlock	IN for temporary suspension of H.V. generation
REM2	B1	Remote ON signal for gun 2	Remote signal IN for gun 2
PAINT2	B2	Paint ON signal for gun 2	Paint signal IN for gun 2
SET2-1	B3	External memory selection 1 for gun 2	Memory selection signal IN, bit 1 for gun 2
SET2-2	B4	External memory selection 2 for gun 2	Memory selection signal IN, bit 2 for gun 2
SET2-3	B5	External memory selection 3 for gun 2	Memory selection signal IN, bit 3 for gun 2
RESET	B6	Fault reset	IN for resetting the fault
IN COM	A7	Common input	Common IN terminal

2) Outputs

Code	No. on terminal block	Designation	Details
H.V.1	A8	High voltage being generated for gun 1	Turns on when a high voltage is generated for gun 1.
FAULT1	A9	Fault pending with gun 1	Turns on when a fault is pending with gun 1.
OUT3	A10	Not used	Not used
H.V.2	B7	High voltage being generated for gun 2	Turns on when a high voltage is generated for gun 2.
FAULT2	B8	Fault pending with gun 2	Turns on when a fault is pending with gun 2.
OUT6	B9	Not used	Not used
OUT COM	B10	Common output	Common OUT terminal

\* "FAULT1" and "FAULT2" can be programmed to be normally closed (opened when the power switch is turned off).

<Side panel>

① LCD contrast adjuster

Adjust the contrast of the unclear liquid crystal display.

② Fan

This Fan is used for cooling BPS290.

Confirm whether the fan is operating, when it is alive.

When the fan is stopped, stop using BPS290 and replace the fan with new one.

 **CAUTION**

**Using the machine with the fan stopped, hinders sufficient radiation, may lead the machine to failure.**

11.3 Example of wiring

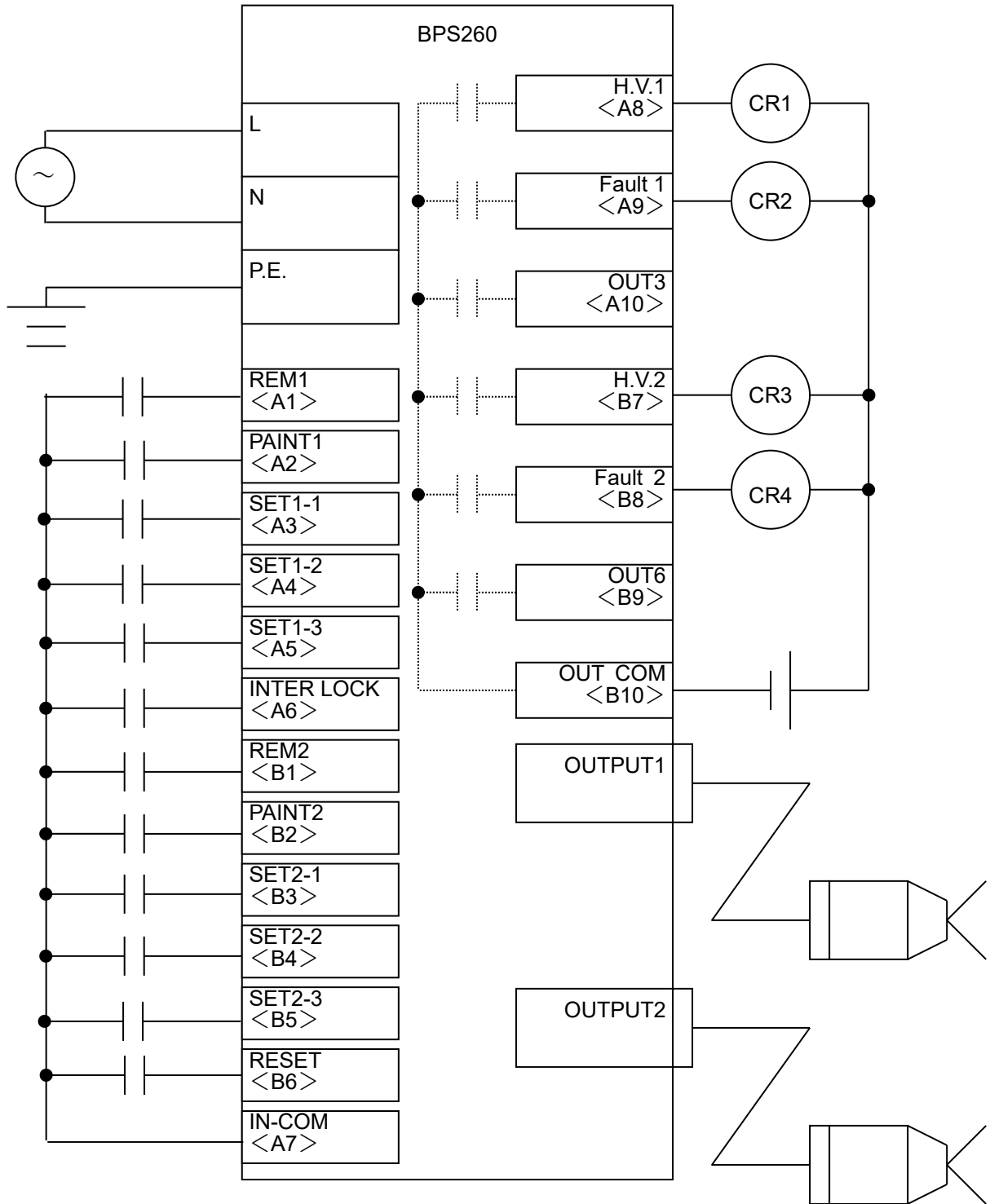

## 11.4 Optional devices

### 11.4.1 Optional external monitor

Designation	Model	Part number	Remarks
MONITER CABLE	—	E-010260-120	

# 12

## Consumable Parts List

Usable life of BPS260 is 10 years except for its consumable parts.

The usable life of the following consumable parts vary depends on the environment of usage.

Its recommend for replace them as for the following reference value of usable life.

The exclusive knowledge and the skill are necessary for the replacement of parts.

Please consult our company or the agency when you exchange it.

Part number	Designation	Number of pieces	Usable life	Remark
E0D2010024100	Switching supply	1	5 years	
E-010260-112	Fan	1	5 years	

# 13

## BPS260 Front Panel Cleaning Method

To clean the BPS260 Front Panel, wipe the dirty part with a soft cloth using neutral detergent or ethanol.

\*Do not use solvents such as acetone, benzene, toluene, and alcohol.



### 15.1 Password page

- Press “SET” for 5 seconds to open the password page.
- System parameter settings can be changed or initialized after entering an appropriate one of the following passwords.
- \* When the keyboard is locked, the password page does not open. First, unlock the keyboard in setting mode.( 9.3 Keyboard locking function)

Password	Function
0260	Used to initialize the BPS260
5280	Used to change system parameter settings

- ① Press “SHIFT” to move the cursor.
- ② Press “△” or “▽” to increase or decrease the value.
- ③ Press “SET” to confirm.

If a password other than shown above is entered, an error page opens. Press any key to return to the password page.

```
< PASSWORD >
X X X X
```

```
PASSWORD NG
```

### 15.2 Initialization of parameters

- Key in “0260” on the password page to open the confirmation page for initialization of parameters.
- Press “SET” to initialize the parameters to the pre-delivery settings.

```
< BPS260 Parameter >
Init[SET]/Stop[NEXT]
```

### 15.3 System parameter settings

- Key in “5280” on the password page to open a system parameter setting page.

#### 15.3.1 Description of pages and bilingual indications

No.	Japanese	English	Description
1.	>OCL セッテイ (シヨウサイ ヒヨウジ <sup>o</sup> セット キー)	>OCL SETTING (DETAILS SET KEY)	The OCL parameter setting selection page. Press the “SET” key to open a detail setting page.
2.	>di/dt セッテイ (シヨウサイ ヒヨウジ <sup>o</sup> セット キー)	>di/dt SETTING (DETAILS SET KEY)	The di/dt parameter setting selection page. Press the “SET” key to open a detail setting page.
3.	>WAOCL セッテイ (シヨウサイ ヒヨウジ <sup>o</sup> セット キー)	>WAOCL SETTING (DETAILS SET KEY)	The WAOCL parameter setting selection page. Press the “SET” key to open a detail setting page.
4.	>ソウテン イジ ヨウ セッテイ (シヨウサイ ヒヨウジ <sup>o</sup> セット キー)	>FEED FAULT SETTING (DETAILS SET KEY)	The feed wire fault parameter setting selection page. Press the “SET” key to open a detail setting page.
5.	>キカン イジ ヨウ セッテイ (シヨウサイ ヒヨウジ <sup>o</sup> セット キー)	>RETURN FAULT SET (DETAILS SET KEY)	The return wire fault parameter setting selection page. Press the “SET” key to open a detail setting page.
6.	>ツウシン セッテイ (シヨウサイ ヒヨウジ <sup>o</sup> セット キー)	>COMM. SETTING (DETAILS SET KEY)	The communication parameter selection page. Press the “SET” key to open a detail setting page.
7.	>ペイント トンカ セッテイ (シヨウサイ ヒヨウジ <sup>o</sup> セット キー)	>PAINT SETTING (DETAILS SET KEY)	The paint ON/OFF triggered dulling parameter selection page. Press the “SET” key to open a detail setting page.
8.	>イジ ヨウ シュツリョク (NO:0/NC:1) x	>FAULT OUTPUT (NO:0/NC:1) x	Select the fault output level (BPS290/260).
9.	>メモリ センタク (ハンメン:0/カ イブ :1) x	>MEM. SELECT PANEL:0/OUTSIDE:1 x	Select the memory selection method.
10.	>ハンメン ソウサ キンシ キノウ x	>KEY LOCK FUNCTION x	Keyboard lock function setting 0: Upon the power-up, the controller starts with the keyboard locked. In the status of the keyboard unlocked, it is locked again by turning OFF the backlight . 1:The keyboard is locked/released each entry of the password. The controller starts with the keyboard kept the previous status.
11.	>イジ ヨウジ <sup>o</sup> レントウ (ゴベ ツ:0/レントウ:1) x	>FAULT (Single:0/All:1) x	Choose to stop the H.V. supply to the faulty gun only or stop it to both guns when a fault occurs.
12.	>メモリセンタク レントウ (ゴベ ツ:0/レントウ:1) x	>MEMORY (Single:0/All:1) x	Choose to select a memory for each gun or link the selection.
13.	インタロック イジ ヨウ リレキ (OFF:0/ON:1) x	INTERLOCK FAULT REC. (OFF:0/ON:1) x	Interlock fault record setting 0: OFF (fault is not recorded), 1: ON (fault is recorded).
14.	>ソフトスタートタイマ x. x Sec	>SOFT START TIMER x. x Sec	Softstart timer for high voltage 「 ON 」
15.	>セッテイ オマリ? オマリ[SET]/ケイゾク [NEXT]	>SETTINGS END? END[SET]/REP. [NEXT]	Press “SET” to open the password entry page. Press “NEXT PAGE” to open the OCL parameter setting selection page.
16.	>>OCL レンゾク カイスウ x カイ	>>OCL CONT. TIMES x TIMES	An OCL detail setting page. Used to specify the successive detection times.
17.	>>OCL トンカ ジカン x. x Sec	>>OCL DULL TIME x. x Sec	An OCL detail setting page. Used to specify the dulling time.
18.	>>OCL トンカ ワリアイ x. x パイ	>>OCL DULL DEGREE x. x TIMES	An OCL detail setting page. Used to specify the dulling degree.
19.	>>di/dt テンリユウ ヘイキン xx カイ	>>di/dt DATA AVERAGE xx TIMES	A di/dt detail setting page. Average number of current detection
20.	>>di/dt ヒカク タイショウ xxx カイマエ	>>di/dt BUFFER xxx	A di/dt detail setting page. Used to specify the comparison target.
21.	>>di/dt トンカジカン x. x Sec	>>di/dt DULL TIME x. x Sec	A di/dt detail setting page. Used to specify the dulling time.
22.	>>di/dt トンカ ワリアイ x. x パイ	>>di/dt DULL DEGREE x. x TIMES	A di/dt detail setting page. Used to specify the dulling degree.
23.	>>di/dt イジ ヨウ シュツリョク (ミケンシュツ:0/ケンシュツ:1) x	>>di/dt DETECT. ? (OFF:0/ON:1) x	A di/dt detail setting page. Used to specify the fault detection on/off status.

No.	Japanese	English	Description														
24.	>>WAOCL レゾク カイスウ x カイ	>>WAOCL CONT. TIMES x TIMES	A WAOCL detail setting page. Used to specify the successive occurrence times.														
25.	>>WAOCL コウシツ カンカク 2 ^ x mSec	>>WAOCL RENEWAL INT. 2 ^ x mSec	A WAOCL detail setting page. Used to specify the weighted average updating intervals														
26.	>>WAOCL ケイスウ xxx	>>WAOCL COEFFICIENT xxx	A WAOCL detail setting page. Used to specify the weighted average coefficient.														
27.	>>WAOCL ムコウ ジカン x. x Sec	>>WAOCL DULL TIME x. x Sec	A WAOCL detail setting page. Used to specify the dull time.														
28.	>>WAOCL イジヨウ シュツリョク (ミケンシュツ:0/ケンシュツ:1) x	>>WAOCL DETECT. ? (OFF:0/ON:1) x	A WAOCL detail setting page. Used to specify the fault detection on/off status.														
29.	>>ソウデン Max. x. xx A	>>FEED Max. x. xx A	A feed wire fault detail setting page. Used to specify the upper limit.														
30.	>>ソウデン Min. x. xx A	>>FEED Min. x. xx A	A feed wire fault detail setting page. Used to specify the lower limit.														
31.	>>ソウデン Max. (OFF) x. xx A	>>FEED Max. (OFF) x. xx A	A feed wire fault detail setting page. Used to specify the upper limit H.V. off-time.														
32.	>>ソウデン ホセイチ xx	>>FEED CORRECTION xx	A feed wire fault detail setting page. Used to specify the upper limit compensation value.														
33.	>>ソウデン カンカク x. x Sec	>>FEED DETECT. INT. x. x Sec	A feed wire fault detail setting page. Used to specify the detection intervals.														
34.	>>ソウデン レゾク カイスウ x カイ	>>FEED CONT. TIMES x TIMES	A feed wire fault detail setting page. Used to specify the successive detection times.														
35.	>>ソウデン トンカ ジカン x. x Sec	>>FEED DULL TIME x. x Sec	A feed wire fault detail setting page. Used to specify the dulling time.														
36.	>>ソウデン イジヨウ シュツリョク (ミケンシュツ:0/ケンシュツ:1) x	>>FEED DETECT. ? (OFF:0/ON:1) x	A feed wire fault detail setting page. Used to specify the fault detection on/off status.														
37.	>>キカン Min. xx uA	>>RETURN Min. xx uA	A return wire fault detail setting page. Used to specify the lower limit.														
38.	>>キカン Max. (OFF) xx uA	>>RETURN Max. (OFF) xx uA	A return wire fault detail setting page. Used to specify the upper limit H.V. off-time.														
39.	>>キカン カンカク x. x Sec	>>RETURN DETECT. INT. x. x Sec	A return wire fault detail setting page. Used to specify the detection intervals.														
40.	>>キカン レゾク カイスウ x カイ	>>RETURN CONT. TIMES x TIMES	A return wire fault detail setting page. Used to specify the successive occurrence times.														
41.	>>キカン ムコウ ジカン x. x Sec	>>RETURN DULL TIME x. x Sec	A return wire fault detail setting page. Used to specify the dull time.														
42.	>>キカン イジヨウ シュツリョク (ミケンシュツ:0/ケンシュツ:1) x	>>RETURN DETECT. ? (OFF:0/ON:1) x	A return wire fault detail setting page. Used to specify the fault detection on/off status.														
43.	>>ツウシツ (OFF:0/ON:1) x	>>COMMUNICATION (OFF:0/ON:1) x	A communication detail setting page. Used to specify the on/off status.														
44.	>>ツウシツ ニュウリョクシツコウ (ツウシツ:0/タンシツ:1/2) x	>>COMM. METHOD (COM:0/TB:1/2) x	Communication detail setting page Selection of the input signal type (Communication/ Terminal block) <table border="1" style="margin-left: 20px;"> <thead> <tr> <th rowspan="2">Setting</th> <th colspan="2">Input signal</th> </tr> <tr> <th>High voltage ON</th> <th>Memory selection</th> </tr> </thead> <tbody> <tr> <td>0</td> <td>Communication</td> <td>Communication</td> </tr> <tr> <td>1</td> <td>Terminal block</td> <td>Terminal block</td> </tr> <tr> <td>2</td> <td>Terminal block</td> <td>Communication</td> </tr> </tbody> </table>	Setting	Input signal		High voltage ON	Memory selection	0	Communication	Communication	1	Terminal block	Terminal block	2	Terminal block	Communication
Setting	Input signal																
	High voltage ON	Memory selection															
0	Communication	Communication															
1	Terminal block	Terminal block															
2	Terminal block	Communication															
45.	>>ツウシツ SCI センタク (CCLink:1/RS485:2) x	>>COMM. SCI selcct (CCLink:1/RS485:2) x	Communication detail setting page Selection of the SCI (CC-Link/RS-485)														
46.	>>ツウシツ キョクバンコウ (ハンコウ:0-15) x	>>COMM. Sta. No. No. x	Communication detail setting page Selection of the station number														
47.	>>^ イント di/dt トンカジカン x. x Sec	>>P di/dt DULL TIME x. x Sec	A paint on/off triggered dulling detail setting page. Used to specify the di/dt dulling time.														
48.	>>^ イント di/dt トンカワリアイ x. x バイ	>>P di/dt DULL DEGREE x. x TIMES	A paint on/off triggered dulling detail setting page. Used to specify the di/dt dulling degree.														
49.	>>^ イント WAOCL ムコウジカン x. x Sec	>>P WAOCL DULL TIME x. x Sec	A paint on/off triggered dulling detail setting page. Used to specify the WAOCL dull time														
50.	>>^ イント トンカ カイジカン x. x Sec	>>P DULL BEGINNING x. x Sec	A paint on/off triggered dulling detail setting page. Used to specify the starting time for dulling.														
51.	>>^ イント トンカ タイミンク x	>>P DULL TIMING x	A paint on/off triggered dulling detail setting page. Used to specify the timing of dulling. 1: On only, 2: Off only, 3: Both on and off														

### 15.3.2 Transition among pages

- Press “△ or ▽” to increase or decrease the setting value.
- Press “△ or ▽” for 5 seconds or longer to increase or decrease it by 10.

For main monitor page

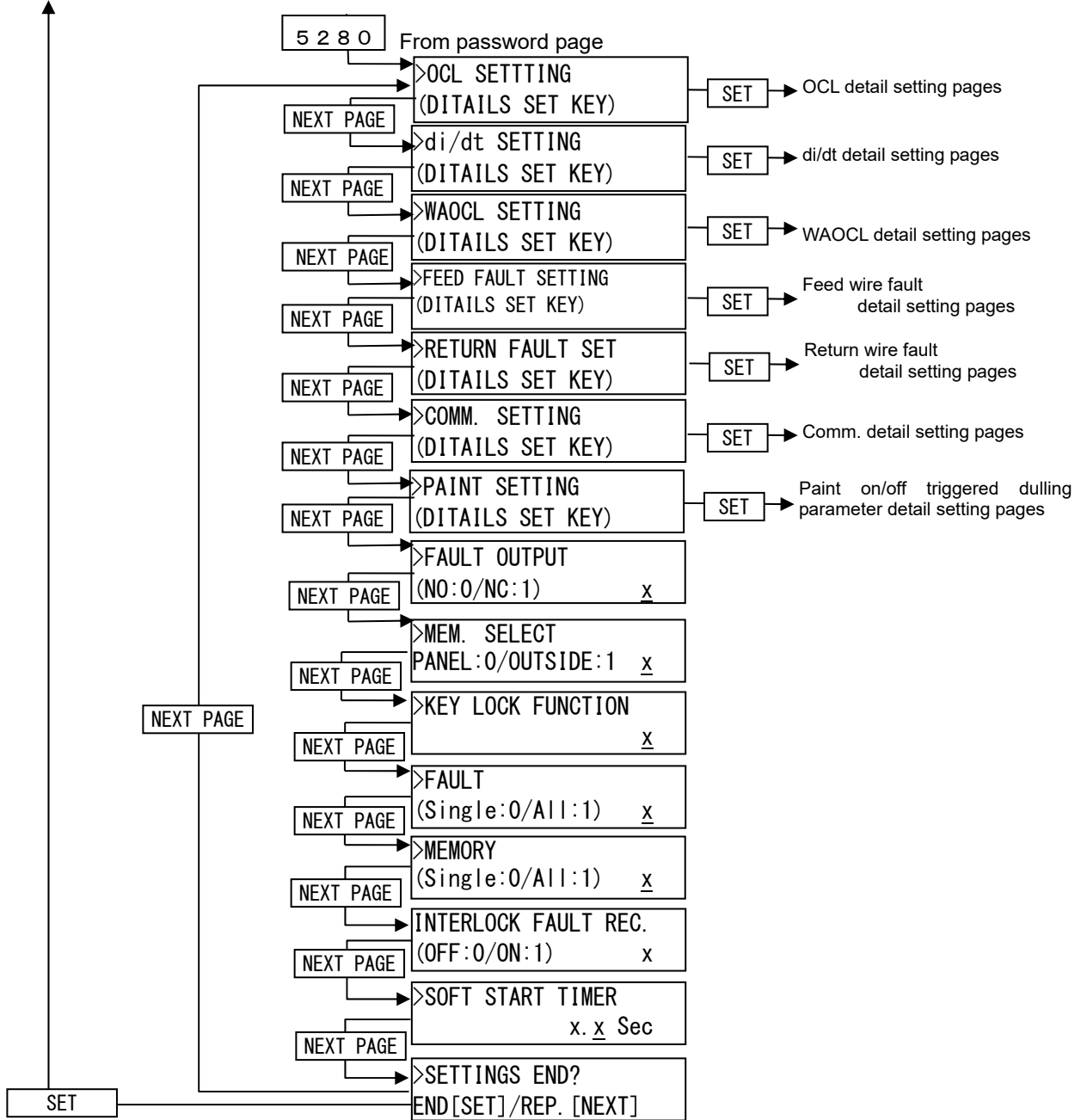

● OCL detail setting pages

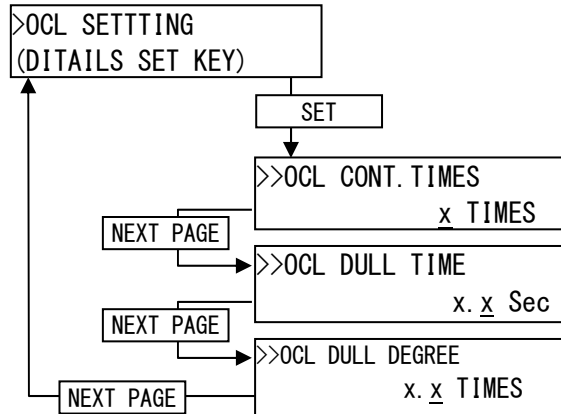

● Di/dt detail setting pages

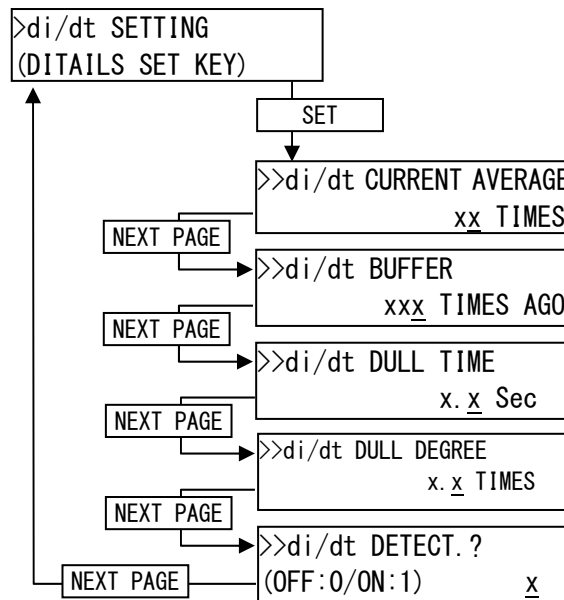

● WAOCL detail setting pages

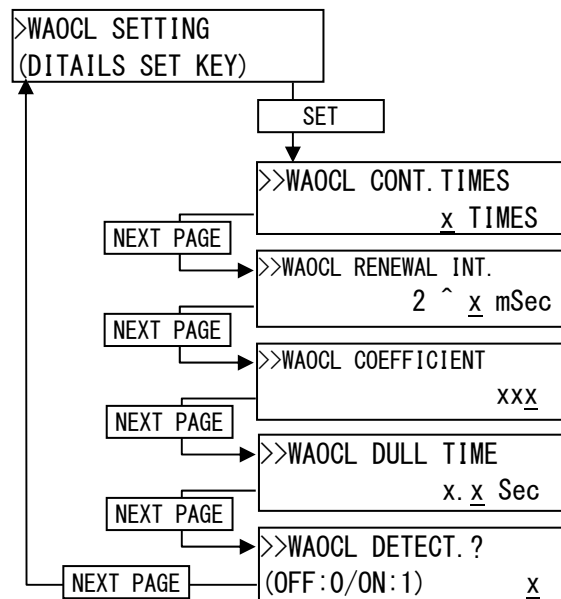

● Feed wire fault detail setting pages

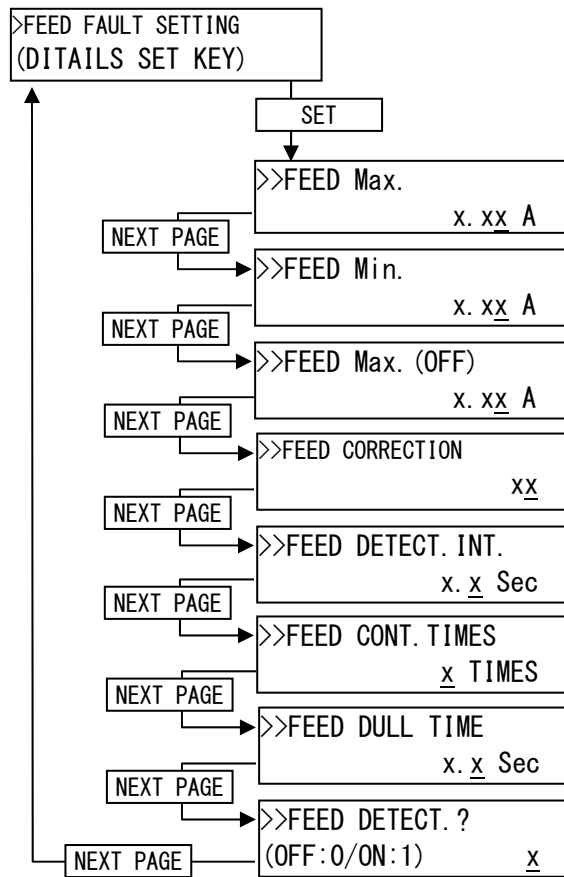

● Return wire fault detail setting pages

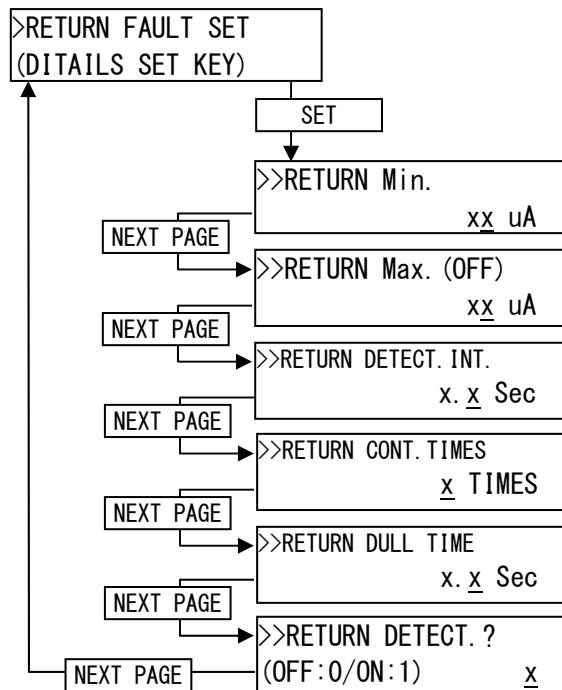

● Communication detail setting pages

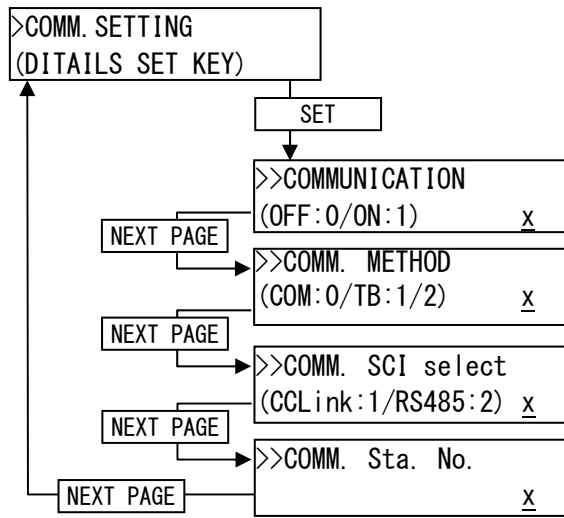

● Paint on/off triggered dulling parameter detail setting pages

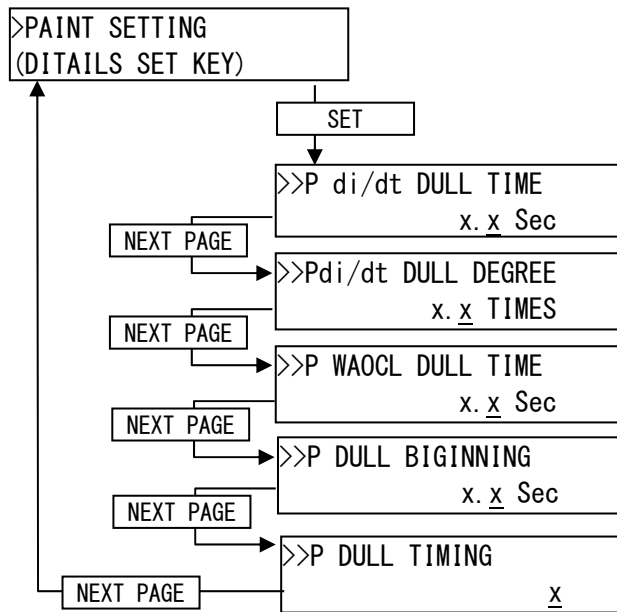

### 15.3.3 List of parameters

No.	Setting item	Unit	Default	Max.	Min.	Setting
1.	OCL: Successive detection times	times	1	20	1	
2.	OCL: Dulling time	secs	0.5	9.9	0.1	
3.	OCL: Dulling degree	times	2.0	9.9	1.0	
4.	di/dt: Average number of current detection	times	4	20	1	
5.	di/dt: Comparison target		88	255	1	
6.	di/dt: Dulling time	secs	1.0	9.9	0.1	
7.	di/dt: Dulling degree	times	6.0	30.0	1.0	
8.	di/dt: Fault detection (1: Detected)		1	1	1	
9.	WAOCL: Successive occurrence times	times	1	10	1	
10.	WAOCL: Weighted average updating intervals (2 <sup>n</sup> ms)		4	7	2	
11.	WAOCL: Weighted average coefficient		50	255	50	
12.	WAOCL: Dull time	secs	1.0	9.9	0.1	
13.	WAOCL: Fault detection (1: Detected)		1	1	1	
14.	Feed wire fault: Upper limit	A	3.00	9.96	0.00	
15.	Feed wire fault: Lower limit	A	0.10	9.96	0.00	
16.	Feed wire fault: Upper limit H.V. off-time	A	0.40	9.96	0.00	
17.	Feed wire fault: Upper limit compensation value		6	10	1	
18.	Feed wire fault: Detection intervals	secs	0.1	9.9	0.1	
19.	Feed wire fault: Successive occurrence times	times	2	99	1	
20.	Feed wire fault: Dulling time	secs	3.0	5.0	0.0	
21.	Feed wire fault: Fault detection (0: Not detected, 1: Detected)		1	1	0	
22.	A return wire fault: Lower limit	μA	2	40	1	
23.	A return wire fault: Upper limit H.V. off-time	μA	10	40	1	
24.	A return wire fault: Detection intervals	secs	0.1	9.9	0.1	
25.	A return wire fault: Successive occurrence times	times	5	99	1	
26.	A return wire fault: Dull time	secs	3.0	5.0	0.0	
27.	A return wire fault: Fault detection (0: Not detected, 1: Detected)		1	2	0	
28.	Communication: Status (0: Off, 1: On)		0	1	0	
29.	Communication: Input signal (0: Communication, 1/2: Terminal block)		0	2	0	
30.	Communication: SCI selection (CC-Link:1/RS-485: 2)		1	2	1	
31.	Communication: Station number		1	15	0	
32.	di/dt at paint on/off: Dulling time	secs	1.0	9.9	0.0	
33.	di/dt at paint on/off: Dulling degree	times	3.0	9.9	1.0	
34.	WAOCL at paint on/off: Dull time	secs	1.0	9.9	0.0	
35.	Starting time for dulling at paint on/off	secs	0.0	9.9	0.0	
36.	Timing of dulling at paint on/off		2	3	1	
37.	Fault output selection: (0: NO, 1: NC)		0	1	0	
38.	Memory selection method (0: Control panel, 1: External)		1	1	0	
39.	Keyboard lock function setting		1	1	0	
40.	Fault (Single:0, All:1)		1	1	0	
41.	Memory (Single:0, All:1)		1	1	0	
42.	Interlock fault record setting (0: Off, 1: On)		1	1	0	
43.	Soft start timer	secs	0.1	9.9	0.1	

\* Setting the upper limit for feed wire fault

Calculate the maximum transmitted current,  $I_{h'}$ , for the setting voltage on a pro rata basis using the "upper limit for feed wire fault" and "compensation value for feed wire fault" shown on the feed wire fault detail setting page.

From the compensation value for maximum transmitted current, k, determine the rate at 0kV as shown below.

Comp value, k	[%]
1	100 (1)
2	50 (1/2)
3	33 (1/3)
4	25 (1/4)
5	20 (1/5)
6	16 (1/6)
7	14 (1/7)
8	12 (1/8)
9	11 (1/9)
10	10 (1/10)

← Default

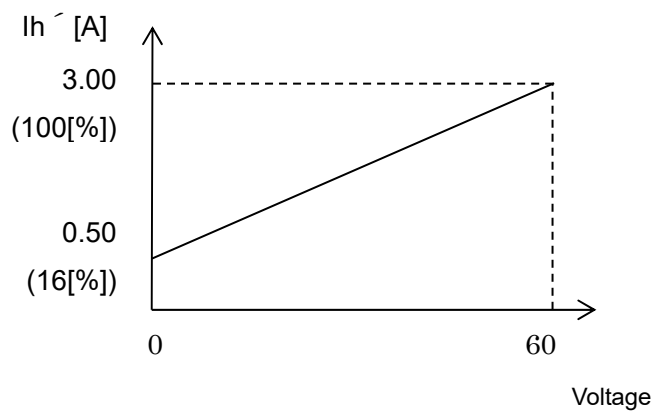

\* With the default compensation value, the maximum transmitted current,  $I_{h'}$ , is 1.33[A] at the selected voltage of 20kV.

● Softstart function

The function works to gradually provide voltage to hold rapid output current when electrostatic controller starts.

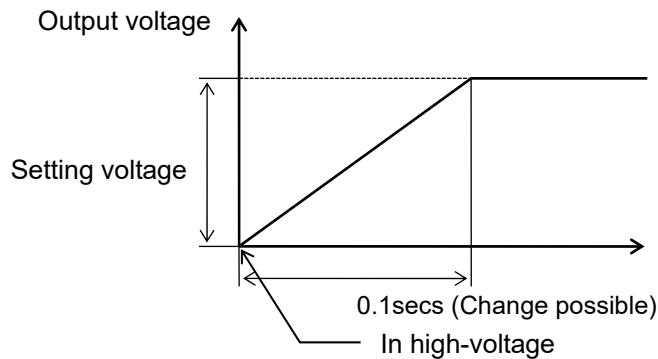

● Timing chart

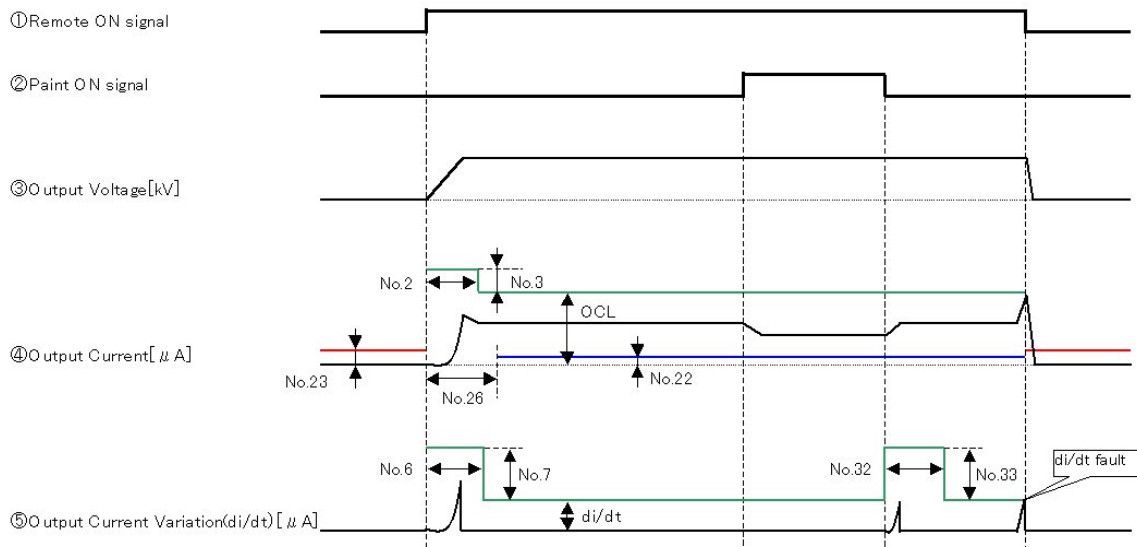

● Serial communication function

① Connecting with SUNAC-EX

<< Setting >>

Set up in the communication detail setting screen as shown bellow.

Setting item		Setting value	
No.28	Communication: Setting	1	Serial communication become valid
No.29	Communication: Selection of the Input signal	0 to 2	Select the input signal from the communication/terminal stand.
No.30	Communication: Selection of the SCI	2	Select RS-485 communication.
No.31	Communication: Station number	5(6)	Select the station number "5". If two BPS260 units are connected for this purpose, select the station number "6" for the second unit.

<<Device communication configuration>>

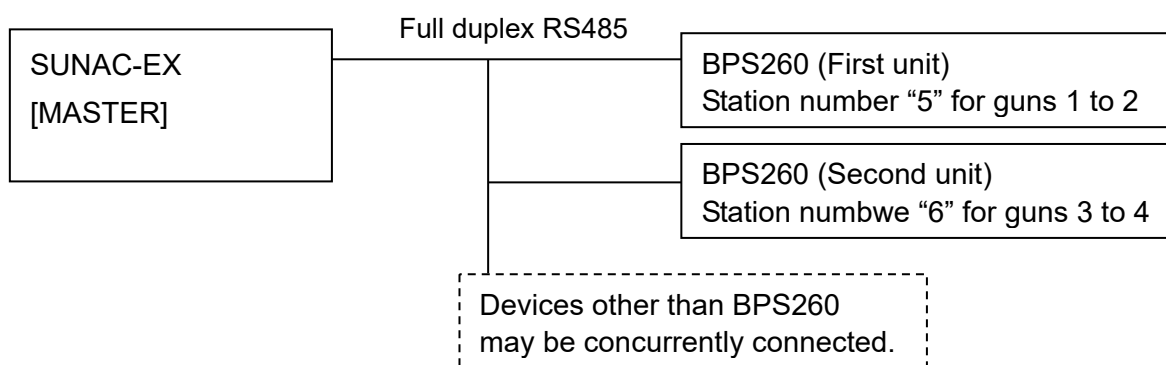

**CAUTION**

Communication is not successfully established with SUNAC-EX unless you select the station number "5" or "6" for BPS260. Communication is not successfully established when more than one same station numbers are used across all devices connected to the same communication either. Please review the setting of the connected devices.

## 15.4 Simple operation mode

### (1) Switching procedure

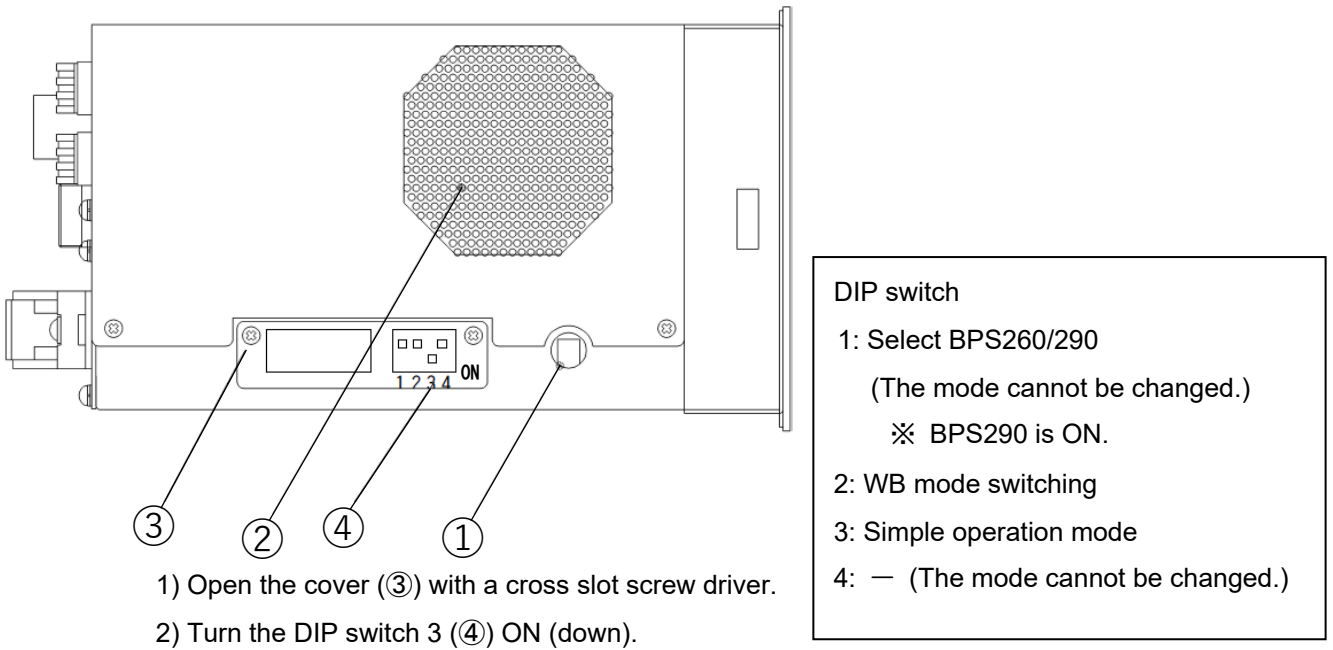

### (2) Description of simple operation mode

- The set voltage can be changed on the main monitor page.

No1	G1 : 20uA (60kV)	No1	G1 : 52kV (60kV)
I	G2 : 17uA (60kV)	V	G2 : 53kV (60kV)

The set voltage can be changed with  $\Delta$  and  $\nabla$ .

※It cannot be changed when you have chosen to select memory.

- A part of the main monitor page

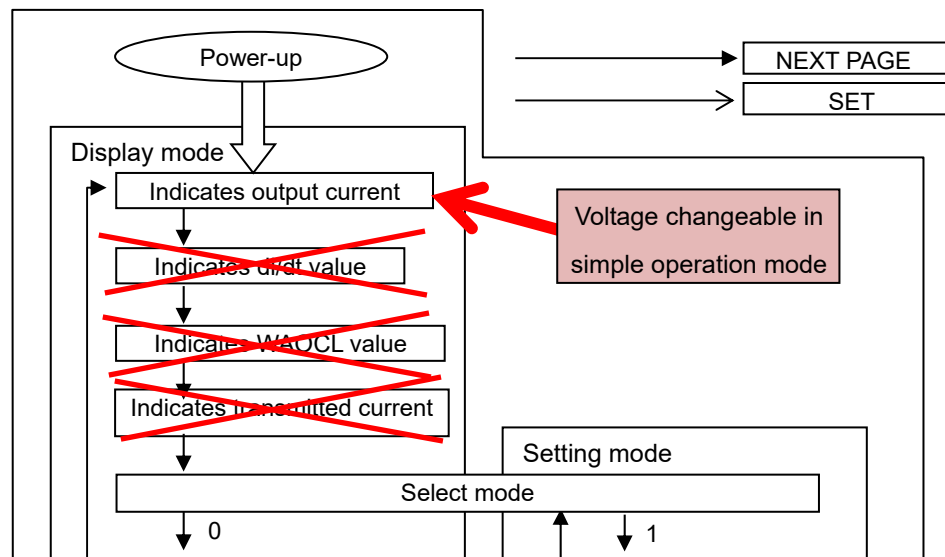

- The voltage should be set to the same value for both guns.
- Memory selection is linked to both guns.
- The keyboard lock function should be fixed to 1 for keyboard unlock.

## 15.5 WB mode

### (1) Switching procedure

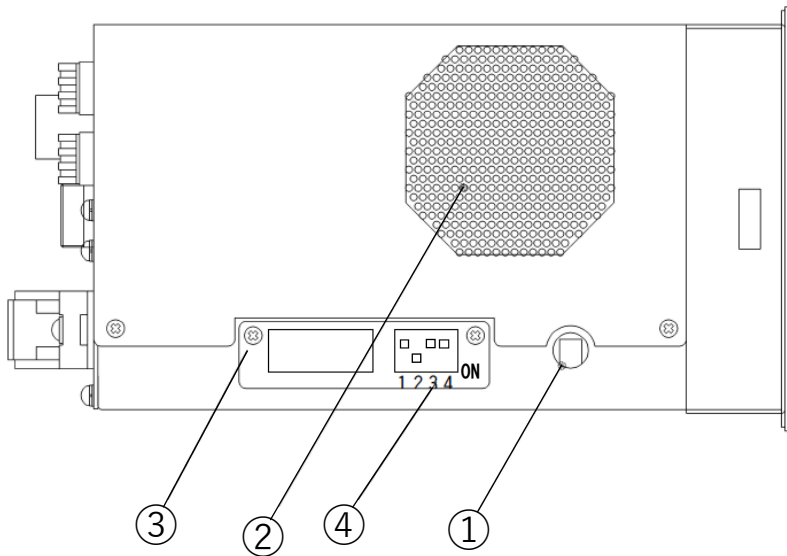

- 1) Open the cover (③) with a cross slot screw driver.
- 2) Turn the DIP switch 2 (④) ON (down).
- 3) Turn the power back on.

#### DIP switch

- 1: Select BPS260/290  
(The mode cannot be changed.)  
※ BPS290 is ON.
- 2: WB mode switching
- 3: Simple operation mode
- 4: — (The mode cannot be changed.)

### (2) WB Mode explanation

- When using water-based paint, set voltage to max. 30kV.
- If the set voltage exceeds 30kV, change it to 30kV.
- Change the lower limit value of the set voltage from 20 to 10.

Edition	Date	Content of revision	Program version
1st	June 17, 2009	—	Ver. 1.00
2nd	October 21, 2009	Program change ( Parameter change (Maximum) , Add soft start function )	Ver. 1.01
3rd	November 27, 2009	CE Marking ( ATEX approved )	Ver. 1.01
4th	February 1, 2010	Program change ( Initial value change )	Ver. 1.02
5th	March 17, 2010	Fuse , Symbol marking of back panel	Ver. 1.02
6th	August 24, 2011	Program change	Ver. 1.03
7th	February 29, 2012	Program change Add timing chart	Ver. 1.04
8th	January 17, 2013	Program change List change ( 7.1 Types of error change )	Ver. 1.05
9th	July 8, 2013	Consumable parts Part number change	Ver. 1.06
10th	October 16, 2013	EN61010-1: 2010-compatible serial gate way disused	Ver. 1.06
11th	May 18, 2015	Program change Add communication function with SUNAC-EX	Ver. 1.08
12th	November 14, 2015	Program change Add setting of external input signal type selection	Ver. 1.10
13th	December 20, 2017	revise typing errors	Ver. 1.10
14th	June 6, 2018	Because EAB400(successor model of EAB90) was released.	Ver. 1.10
15th	October 2, 2018	Add how to clean the front panel Add discription of Branch Circuit Protection.	Ver. 1.10
16th	April 22, 2019	Program change Circuit board change	Ver. 2.00
17th	February 3, 2020	Add ATEX related matters	Ver. 2.00
18th	July 14, 2020	Replace the drawing(Back panel)	Ver. 2.00
19th	September 1, 2020	Change of sentence	Ver. 2.00
20th	May 17, 2022	Program change ( Initial value change )	Ver. 2.02
21th	December 26, 2022	EN50050-1: 2013-compatible	Ver. 2.02
22th	March 7, 2024	Corrected Dip switch details Added WB mode description	Ver. 2.02

ASAHI SUNAC CORPORATION (the “Company”) shall provide the original purchaser (the “Purchaser”) with warranty service for a period of one (1) year from the date of purchase of the product, as follows:

- Should you find defects in design or workmanship with regard to parts, ship them back to the Company, with freight prepaid. The Company shall repair or replace the parts free of charge and reimburse the freight charges, provided that, as a result of an inspection and investigation of the parts conducted by the Company, the defects are deemed to be attributable to the factors within the Company’s responsibility.
- In the following cases, free after-sales service is not provided.
  1. Failure resulting from an inappropriate method of installing this equipment.
  2. Failure resulting from a use method not conforming to this instruction manual or mishandling.
  3. Failure resulting from insufficient maintenance management of this equipment and incorrect handling such as non-conformance to the procedures specified in this instruction manual.
  4. Failure resulting from unauthorized alteration or structure change of this equipment without the Company’s consent.
  5. Failure due to force majeure such as earthquake, disaster, flood disaster or lightning.
  6. Warranty for consumables worn or deteriorated even in the case where this equipment is used correctly.
  7. Repair after the machine has been used outside Japan, and shipping cost.
  8. In addition to the above, failure due to circumstances beyond our control.
- As for items such as parts purchased by the Company from another manufacturer, the warranty of that manufacturer shall apply.
- As for any parts deemed to be defective, the Company shall not be held liable for any expenses beyond the provision of repair or replacement parts free of charge.
- The Company shall not be held liable for any damage to the Purchaser caused by factors not attributable to the Company, such as misuse of product, etc.

【MEMO】



- 
- When transferring the machine, always attach this document to the machine so that it will be used by the next owner.
  - The machine is manufactured in compliance with Japanese laws.  
When using the machine in a country other than Japan, it is necessary to comply with safety standards in that country.
- 

22th Edition: March 7, 2024

## ASAHI SUNAC CORPORATION

HEAD OFFICE  
5050, SHINDENBORA, ASAHIMAE-CHO,  
OWARIASAH, AICHI PREF. 488-0852, JAPAN  
PHONE +81-561-52-0717 FAX +81-561-54-8847

URL : [www.sunac.co.jp](http://www.sunac.co.jp)  
E-mail : [ctrd01@sunac.co.jp](mailto:ctrd01@sunac.co.jp)

Sales office



English



Chinese

22th Edition: March 7, 2024