

# Operation and Maintenance Manual

Automatic Electrostatic Air Spray Gun  
Sungun III

*EAB500*



This manual contains important information on warnings and cautions. Read the manual thoroughly before starting to operate the equipment, and follow the instructions. Always keep the manual handy until such time as the equipment is no longer being used. If your manual is lost or worn badly, do not hesitate to contact our agency which is closest to you, or the Asahi Sunac Corporation, directly, and ask us to send you a new one.

# Introduction

Thank you for purchasing our product automatic electrostatic air spray gun Sungun III < EAB500>.

Please be sure to read this operation manual carefully before using this product so that you can always use it under the optimum conditions.

In particular, please fully understand the items in the specifications and use them according to the correct usage.

This product is used in combination with an electrostatic controller (BPS290).

Be sure to read the operation manual of the electrostatic controller carefully.

If you have any questions, please contact us by clearly stating the "product number" and "serial number" and contacting us on the back cover.



**Please keep this operation manual in a safe place where you can easily refer to it.**

<b>1</b>	For safe and correct use	1
<b>2</b>	Equipment Overview	7
	2.1. Names and roles of main unit parts	7
	2.2 Names of Connections on Back Plate	8
	2.3 Items on Rating Plate	8
	2.4 Component of Gun (Main Body)	9
	2.5 Related Accessory Parts (Optionally Available)	9
	2.5.1 Air cap (Model: HN Series)	9
	2.5.2 Electrostatic controller (BPS290 Series)	10
	2.5.3 Power transmission cable	10
	2.5.4 Gun bracket	10
	2.5.5 Paint hose	11
	2.5.6 Maintenance tool set	11
	2.5.7 Other component parts	11
<b>3</b>	Specifications	12
	3.1 Outline Drawing	12
	3.2 Product Specifications	12
<b>4</b>	Installation	13
	4.1 Reference Piping Layout	13
	4.2 Installation of Reciprocator	13
	4.3 Installation of Control Panel	14
	4.4 Installation of Paint Feeder and Air Control Paint Regulator	15
	4.5 Electric Work	15
	4.6 Air Piping Work	16
	4.7 Paint Piping Work	17
	4.8 Installation of Air Cap	18
	4.9 Inspections	19
<b>5</b>	Precautions before Operation	20
<b>6</b>	Preparation for Coating	21
	6.1 Paint	21
	6.2 Adjustment of Air	23
	6.3 Spraying Distance	24
	6.4 Travel Speed	24
	6.5 Paint Spray Cut	24
	6.6 Voltage Applied	24
	6.7 System Operation Procedures	24
	6.8 Precautions to Be Taken at Stoppage and End of Spraying Operations	25

<b>7</b>	Maintenance and Inspection .....	28
	7.1 Procedure to Finish Operation .....	28
	7.1.1 When the operation is resumed within 24 hours .....	28
	7.1.2 When the operation is not resumed within 24 hours .....	31
	7.2 Maintenance of Other Equipment .....	33
	7.3 Periodical Inspections .....	33
	7.4 Consumable Part .....	35
<b>8</b>	Coating Problems and Solutions .....	36
<b>9</b>	Troubleshooting .....	38
<b>10</b>	How to Replace Parts .....	40
	10.1 Replacing Air Cap .....	40
	10.2 Replacing Paint Nozzle ASSY .....	40
	10.3 Replacing Charge Electrode .....	41
	10.4 Replacing Paint Seat .....	41
	10.5 Removing Shroud .....	42
	10.6 Disassembling Front Block ASSY .....	42
	10.7 Disassembling Bellows Seal ASSY .....	43
	10.8 Removing Extension .....	44
	10.9 Replacing Piston ASSY .....	45
	10.10 Installing Paint Hose and Plug .....	46
	10.11 Installing Orifice .....	47
<b>11</b>	Exploded Diagram and Names of Parts .....	48
	11.1 EAB500 .....	48
	11.2 Replacement Parts .....	49
<b>12</b>	Maintenance Log .....	51
<b>13</b>	Warranty .....	52

Please understand the contents of this instruction manual and be sure to follow the handling method. If you use it without following this instruction manual, **you may injure your body or damage your equipment and fire.**

The following safety precautions should be considered as minimum basic safety measures when using our products.

● **Precautions are displayed in the following two stages.**



**WARNING**

Hazards that can result in death or serious injury.



**CAUTION**

Danger that may result in minor or moderate injury or physical damage only.

● **Other important points are indicated as follows:**

**NOTE**

Observations to ensure the equipment's performance and functions are fully operational.

In addition, please observe all national and local laws and regulations related to fire, electricity, and safety, as well as the rules and regulations of your own company or business division.

« **Range of use suitable for the product** »

This product is an automatic spray gun designed to be installed in the coating booth equipped with an exhaust system and used for painting with air electrostatic atomization paint.

If you use the product under conditions other than the above, it will be used improperly. Also, please be careful as it may cause an accident.

 **WARNING**

**Fire and explosion**



**Preventing fire and explosion in coating shop**

- **Do not use halogenated hydrocarbon solvents.**  
The aluminum alloy contained in this product's components may undergo a chemical reaction and explode.
- **Do not use this product outside its specifications.**  
Using it out of specification range may result in a fire hazard.
- **Provide adequate ventilation with ventilation equipment.**  
Volatilized organic solvents and other substances may remain and ignite, creating a risk of fire.
- **Clean the coating room and exhaust system (ducts and fans) regularly.**  
If the accumulated powder simply peels off, a spark may occur, which could cause a dust explosion.  
In the unlikely event of a fire, paint residue etc. will make it easier for the fire to spread and result in greater damage.



**Prevent fire and electric shock caused by faulty earthing**

- **All conductive objects in the coating booth (paint containers, peripheral equipment, etc.) must be grounded with an earth wire.**  
In an atmosphere ionized by high voltage, poorly grounded conductors can become charged, creating a risk of fire or electric shock due to spark discharge.  
The earth should be **Class D grounding or higher** (ground resistance 100 Ω or less).
- **Always keep the workpiece earthed.**  
Risk of fire or electric shock due to spark discharge from charged workpieces.
- **Paint hose must be grounded with an earth wire.**  
Static electricity can cause spark discharge, which can result in fire or electric shock.  
When paint flows through the injector and paint hose, static electricity is generated and becomes charged.
- **The paint container must be grounded with an earth wire (excluding the insulated stand specifications).**  
The paint path can cause the paint container to become charged, a risk of fire or electric shock.
- **The electrostatic controller must be grounded with an earth wire.**  
Static electricity can cause spark discharge, which can result in fire or electric shock.  
Connect the earth wire with screws or other fasteners to prevent it from coming loose.

 **WARNING**

**Fire and explosion**



**Prevent fire and electric shock caused by faulty earthing**

- **Be sure to periodically remove any paint that has stuck to the hanger.**  
If paint adheres to the contact part between the hanger and the object, there is a risk of fire or electric shock due to poor earthing.  
The ground resistance value should be 1kΩ or less for metal (1MΩ or less for resin) (measurement voltage should be 500V or more).
- **Do not place any items in the coating booth that are not necessary for coating.**  
Static electricity can cause spark discharge, which can result in fire or electric shock.
- **Paint operator must take precautions to prevent static electricity.**  
Static electricity builds up on the human body, causing sparks to discharge, which may result in fire or electric shock.



**Prevent fires caused by ignition of paints and solvents**

- **When nozzle cleaning, turn off the power to the electrostatic controller.**  
If high voltage is applied during nozzle cleaning, there is a risk of fire.
- **Do not bring any spark-producing devices, matches, lighters, etc.**  
Risk of explosion or fire due to ignition of flammable materials.

**Equipment misuse**



**Preventing accidents caused by poor maintenance**

- **Any abnormal noise, vibration or high voltage leakage, immediately stop operation.**  
Product damage may result in a fire hazard.
- **Do not operate if any parts are damaged or missing.**  
Product damage may result in a fire hazard.

 **WARNING**

**Human protection**



**Protection from high voltage**

- **Please wear anti-static shoes.**  
Static electricity builds up on the human body, causing sparks to discharge which may result in fire or electric shock.
- **Do not approach and touch the gun body while high voltage is applied.**  
Touch with high voltage parts may result in electric shock.
- **The coating work floor must have an anti-static construction with a leakage resistance of 1 MΩ or less.**  
There is a risk of electric shock to the operator.  
The scope of the antistatic structure is the entire work floor in a closed paint room.  
In an open paint booth, it is the area surrounded by 1.5m on either side of the booth opening and 2.5m in front of it.  
To maintain the antistatic effect, clean the work floor when it becomes dirty.
- **Do not use this product if you have a pacemaker.**  
The high voltage of this product may cause pacemakers to malfunction or stop functioning.



**Protection from solvents, air and paint pressure**

- **Do not spray paint towards person**  
Harmful substances may cause serious injury, including inflammation and poisoning.  
Pressurized paint can cause personal injury.
- **Wear protective glasses, a protective mask, and protective gloves\*<sup>1</sup> when handling paint.**  
Harmful substances may cause serious injury, such as inflammation or poisoning.  
Carefully read the safety data sheet (SDS\*<sup>2</sup>) of the paint you are using and take appropriate exposure prevention and protective measures.  
\*<sup>1</sup> When using protective gloves for skin absorption protection or to prevent dirt, it is necessary to prevent static electricity from building up on the human body.  
Be sure to ground it properly. (Recommended protective gloves are those specified in JIS T8118, or earth bands, etc.)  
\*<sup>2</sup> SDS : Safety Data Sheet
- **Clean the coating room and exhaust device (ducts and fans) regularly.**  
If the exhaust device does not function properly, harmful substances may cause serious injury, including inflammation and poisoning.

《Warning and precautions for safe use》

 **WARNING**

- **Do not use this product outside its specifications.**  
Using it out of specification range may result damage to the product.
- **Do not immerse the coating machine, connection/extension cable or hoses in cleaning solvent.**  
Electrostatic sprayer are electrical machines, immersing them in cleaning solvents may cause break down.
- **Connection/extension cable and hose should be hung from the ceiling or side walls and not dragged across the floor.**  
It may cause damage such as scratches.  
When using conductive paint, be sure to suspend the paint hose from an insulating material such as a rubber tube.
- **Never use a metal brush to clean the sprayer or its components.**  
It may cause scratches, breakdowns, and poor coating results.  
The nozzle and electrode are important parts of the sprayer.  
If you use a metal brush to scratch it, uniform coating will not be possible.
- **Always keep a distance of at least 150mm between the tip of the nozzle and the work piece.**  
The potential at the tip of the nozzle will decrease, causing poor coating results.
- **Check frequently for paint leaks, air leaks, and loose screw.**
- **Do not touch the electrode pins of the spray gun carelessly.**  
The electrode pin may pierce the body and cause injury.  
Be careful when handling the electrode pin as they are easily pierced.

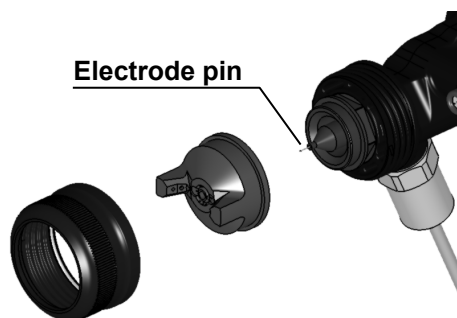

《Warning and precautions for safe use》

 **WARNING**

• **Do not install it like following.**

Electrostatic guns apply high voltage to the tip of the gun and the rear is earthed, make sure there are no obstacles on the main body (insulated part).

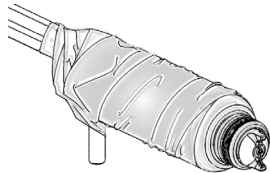

① If the gun is used with the dirt-proof sheet wrapped around it, moisture will accumulate inside, causing an overcurrent error.

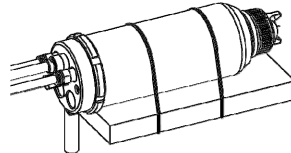

② If a metal plate is attached close to the gun body, insulation breakdown may occur between the charged part of the gun and the plate.

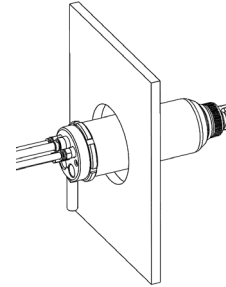

③ If the gun body is inserted through a hole in a metal plate, insulation breakdown may occur, just as in ②.

● **A fire extinguisher should always be kept near the work area.**

In case of a fire, make sure to have equipment that has been regularly inspected installed at all times.

● **When disposing of this product, please dispose of it in accordance with the laws of your country.**

# 2

## Equipment Overview

### 2.1 Names and roles of main unit parts

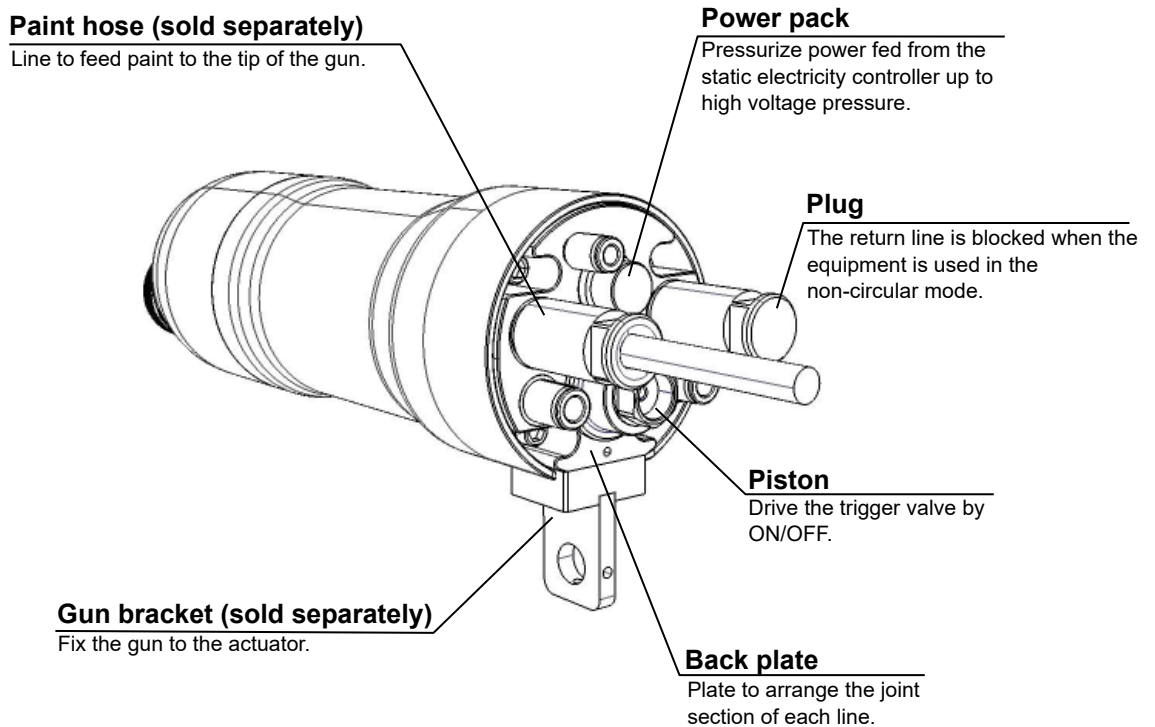
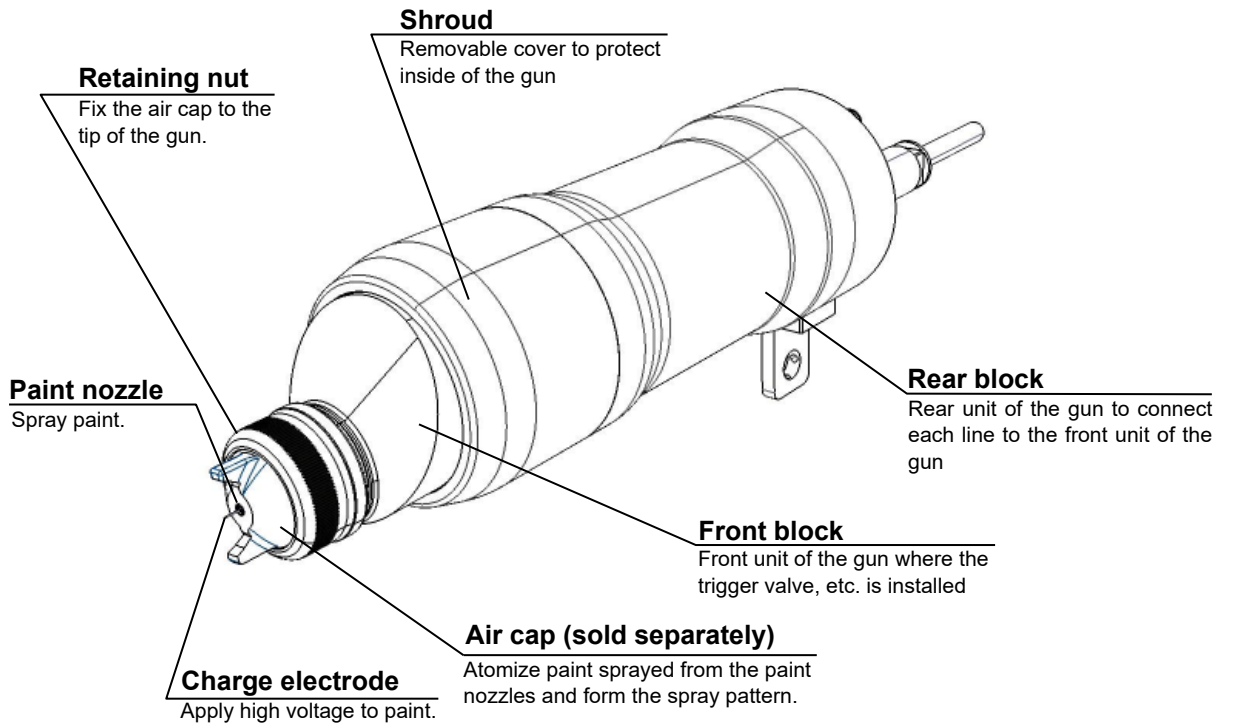

## 2.2 Names of Connections on Back Plate

“TAOP”: Paint valve operating air:  
Fitting size upon shipment  
OD 6 mm - ID 4 mm/RC (R) 1/8

Connection cable

“P-IN”: Paint IN port

“P-OUT”: Paint OUT port  
\*For paint circulation/drain

“PA”: Pattern air:  
Fitting size upon shipment  
OD 8 mm - ID 6 mm/Rc (R) 3/8

“AA”: Atomizing air:  
Fitting size upon shipment OD 8 mm - ID 6 mm/Rc (R) 3/8

Hole to check valve paint leakage

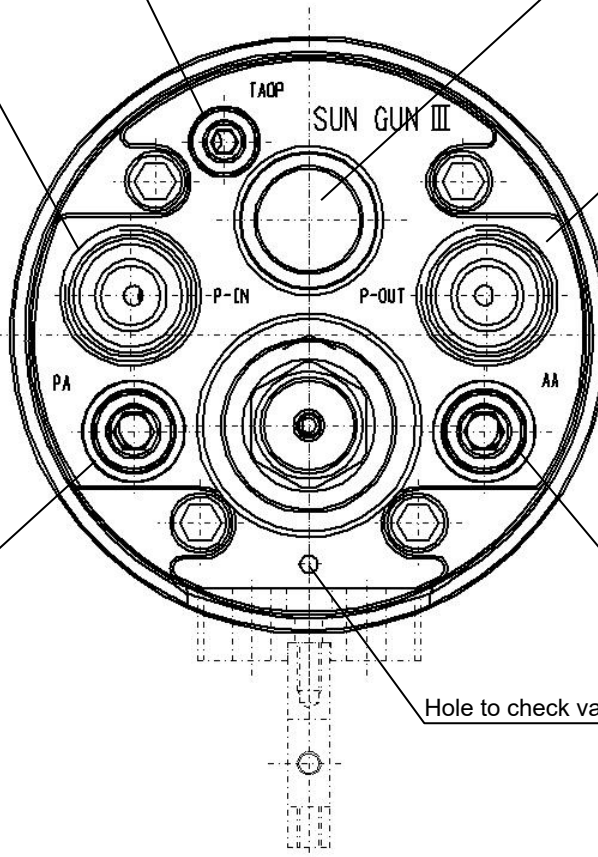

## 2.3 Items on Rating Plate

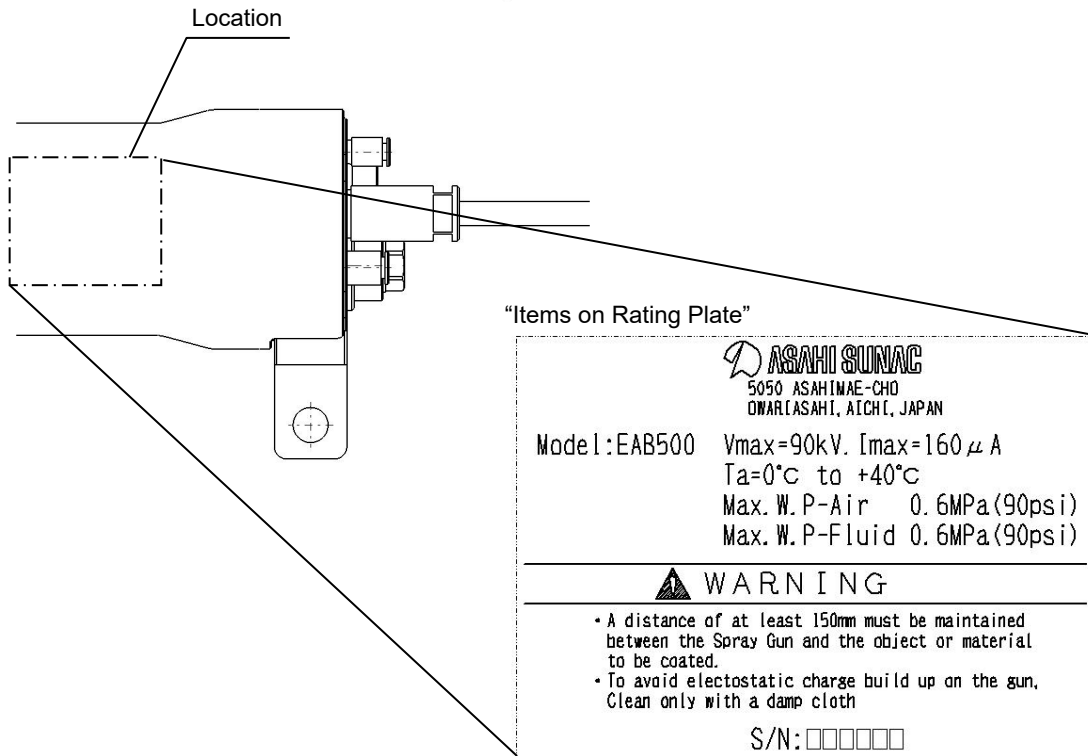

## 2.4 Component of Gun (Main Body)

### ① Sungun III automatic electrostatic air spray gun (EAB500)

The gun (main body) is equipped with the power pack (high-voltage generator) and has air and paint lines of the paint discharge valve (trigger valve).

This product is in the non-circular mode in the default setting. To use the product in the circular mode, you need to replace the plug with the supplied part.

### ② Paint nozzle

The paint nozzle has a role to discharge paint from the tip of the gun and switch pattern air and atomizing air.

### ③ Charge electrode

The charge electrode applies high voltage to the paint discharged from the tip of the gun to perform electrostatic coating.

## 2.5 Related Accessory Parts (Optionally Available)

- The related accessory parts and maintenance tools are necessary for running and operation of this product. Select appropriate equipment from those listed below according to the usage and conditions and **procure them separately**.
- When you procure products and/or parts of the related accessory equipment, be sure to check the part numbers and quantities in the relevant instruction manuals.

### 2.5.1 Air cap (Model: HN Series)

- A part which is mounted at the tip of the coating equipment and enables atomization and pattern formation using power of air.
- Select an air cap from the table below with the specifications which meet your usage.

Image Figure of HN Series Air Cap

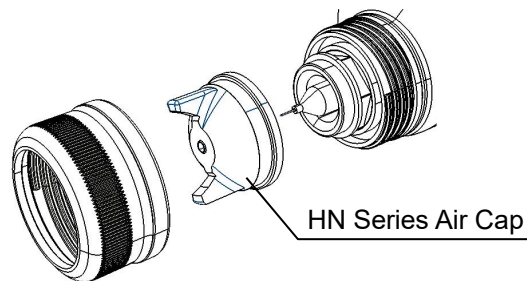

\*All the HN Series caps can be used for common paint nozzle ASSY.

<How to Select Air Cap>

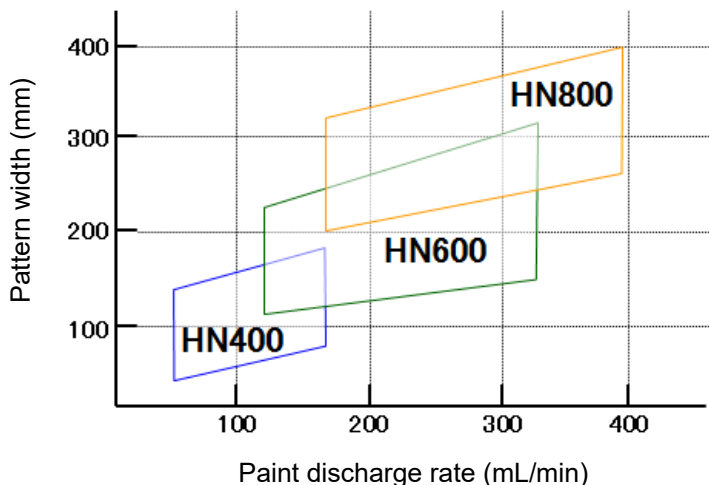

Part No. of air cap

Model	Usage	Parts No.
HN400	Narrow pattern	15F8-001
HN600	General	15F8-101
HN800	Fine atomization	15F8-201

## 2.5.2 Electrostatic controller (BPS290 Series)

- A device to control high-voltage application of the built-in cascade of the coating machine. It also detects and outputs various errors by monitoring the current value while the equipment is in operation.

### External View of BPS290 Series

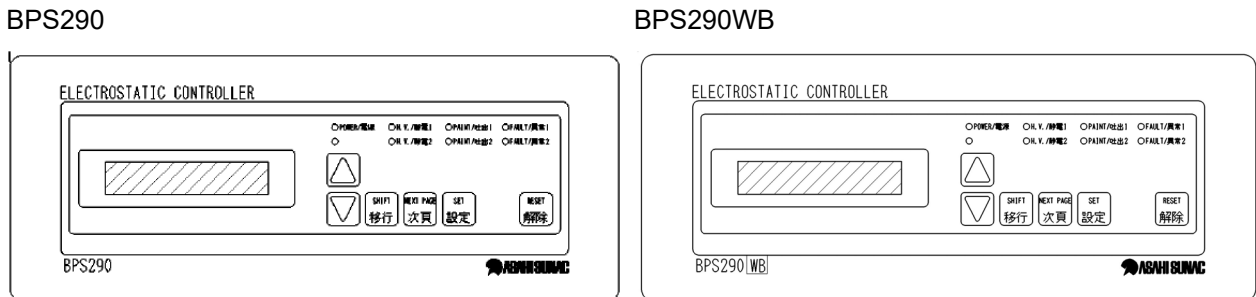

\*For details of the specifications, see the instruction manual of BPS290/BPS290WB.

#### Electrostatic controller part No. list

No.	Part Name	Parts No.	Specifications
1	BPS290	445-0161	English/Japanese Ver.
2		445-0162	English Ver.
3	BPS290WB	6637	For water paint insulation stand method *Max. applicable voltage setting = -50kV English/Japanese Ver.

## 2.5.3 Power transmission cable

- You can connect the “connection cable” and “extension cable” up to 30 m between the coating equipment and electrostatic controller and use them as a power transmission cable.

#### Connection cable part No. list

No.	Part Name	Parts No.	Specifications
1	Connection cable	2535	10 m

#### Extension cable part No. list

No.	Part Name	Parts No.	Specifications
1	Extension cable	2530	10 m

\* To extend the length to 30m, use 2pcs of extension cable (No.2530).

## 2.5.4 Gun bracket

#### Gun bracket part No. list

No.	Part Name	Parts No.	Specifications
1	Gun bracket	1833-060	For M14 bolt

### 2.5.5 Paint hose

- A paint hose to feed paint from the pump to the paint equipment.

These hoses have a double-layered structure; they can be used with a paint with a low electric resistance value.

#### Paint hose (metal fitting specifications) part No. list

No.	Part Name	Parts No.	Specifications
1	Paint hose	3463	1 m
2	Paint hose	3463-1	5 m
3	Paint hose	3463-2	10 m

#### Paint hose (resin fitting specifications) part No. list

No.	Part Name	Parts No.	Specifications
1	Paint hose	3464	1 m
2	Paint hose	3464-1	5 m
3	Paint hose	3464-2	10 m

### 2.5.6 Maintenance tool set

- While you can perform preventive maintenance and repair/replace a part when a failure occurs by replacing a relevant ASSY, use this set of maintenance tools which contain dedicated tools for detailed parts replacement and maintenance of the cascade ASSY, etc. and tools to control the torque more strictly.

For your information, "ASSY" refers to an assembly part which consists of 2 or more parts.

- \* If you need detailed maintenance, we will provide you with maintenance training.  
It is recommended that detailed maintenance should be done by a person who has received the maintenance training specified by our company.  
For the maintenance training, please contact our staff in charge.

#### Maintenance tool set

No.	Part Name	Parts No.	Remarks
1	Maintenance tool set	35EF	

\*For the detailed specifications and part number of each tool, please contact our staff in charge.

### 2.5.7 Other component parts

- ① Paint supply pump ⇒ Refer to the PD series (diaphragm pump).  
Refer to the GP series (gear pump).
- ② Air control paint regulator ⇒ Refer to the MR series.
- ③ Drain valve ⇒ Refer to the CCV2PA/S,3PA/S series.
- ④ Control panel ⇒ Please contact our staff in charge.

# 3

## Specifications

### 3.1 Outline Drawing

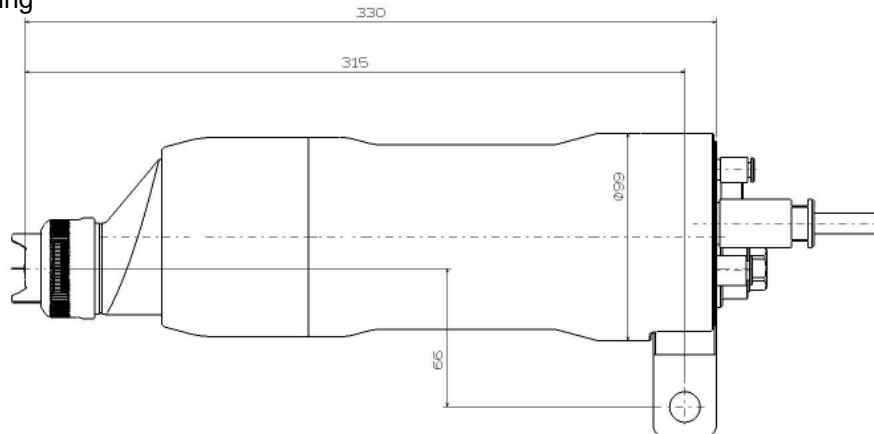

### 3.2 Product Specifications

Model	EAB500
Dimensions	φ99 × 330 mm
Weight	2,700 g *Including the paint nozzle and plug; The paint hose and gun bracket are excluded.
Maximum hydraulic pressure	0.6 MPa
Maximum air pressure	0.6 MPa
Maximum voltage applied	DC-90kV (DC-50kV for BPS290WB)
Maximum current	160 μA
Trigger valve working pressure	Minimum working pressure: 0.3 MPa Normal working pressure: 0.4 to 0.5 MPa
Applicable air cap	HN400/HN600/HN800
Electrostatic controller	BPS290 series
Connection cable length	10 m *The connection cable can be extended up to 30 m in combination with an extension cable.
Environment	Temperature: 5 to 40°C; Humidity: 40 to 80%
Supply air conditions	Solid particle size: 0.1 μm or less Dew point under pressure: 10°C Atmospheric dew point: -17°C Remaining oil: 0.01 mg/m <sup>3</sup>

### NOTICE

The temperature of the paint must be 40°C or lower when it is supplied. If the temperature of the paint is high, the paint hose may soften and come off.

### NOTICE

For the paint pressure feed system and paint regulator, refer to their instruction manuals. The paint feeding pressure must be 0.6 MPa or lower.

# 4

## Installation

### 4.1 Reference Piping Layout

A typical system piping layout of this equipment is shown below.

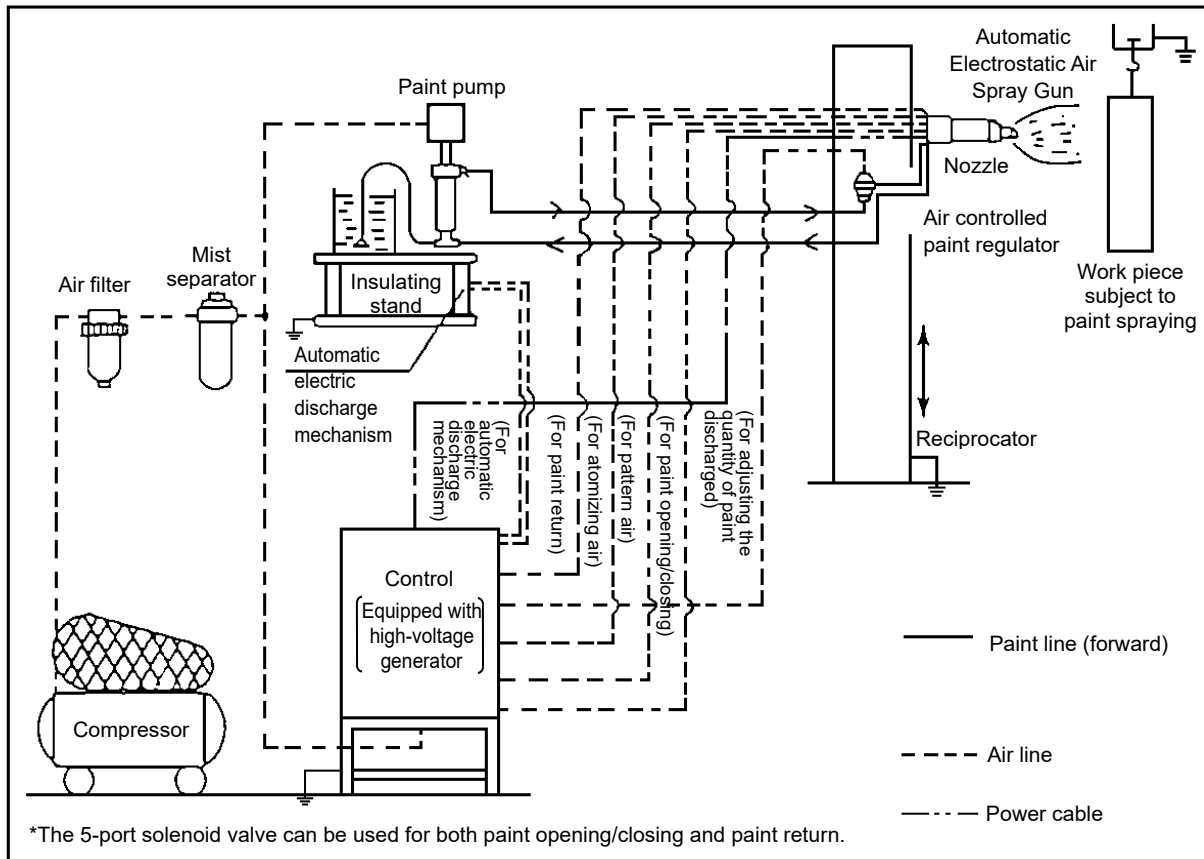

This piping layout is an example when this product is mounted on a reciprocator. For other system and details of installation, please determine the layout based on the installation work specification as well as to this manual.

### 4.2 Installation of Reciprocator

- ① Put the frame in a horizontal position.

The frame must be installed under the conditions described below.

- The tip of the automatic electrostatic air spray gun nozzle is located 150 to 200 mm away from the work piece subject to paint spraying and the reciprocator is located in the center of the frame.
- The center of the automatic electrostatic air spray gun nozzle is located approx. 800 to 1000 mm away from each wall of the coating booth.

- ② Put the reciprocator on the frame.
- ③ Secure the frame with its anchor bolts.
- ④ Fix the forward/backward movement adjusting screw's bracket to the lower part of the reciprocator (with its bolts).

- ⑤ Fix the arm pipe to the carrier plate (with bolts).

In this step, the length of the arm pipe should be adjusted to meet the following requirements:

- The side wall of the reciprocator is located 300 to 400 mm away from the automatic electrostatic air spray gun or air control paint regulator; and
- The automatic electrostatic air spray gun is located 300 to 400 mm away from its neighboring the automatic electrostatic air spray gun.

- ⑥ Insert the mounting brackets for the automatic electrostatic air spray gun and air control paint regulator into the arm pipe.

- ⑦ Fix the automatic electrostatic air spray gun and air control paint regulator to the mounting brackets.

- ⑧ Apply oil or grease to the parts that need oiling.

- ⑨ Tighten the fixing bolts at the lower part of the reciprocator and fix the reciprocator to the frame.

- ⑩ Fix the reciprocator's top board in place.

## CAUTION

If the automatic electrostatic air spray gun is located close to the side wall of the reciprocator, air control paint regulator, or another automatic electrostatic air spray gun, those devices will be subjected to adhesion of more paint, their safety devices (overcurrent protection circuits) may malfunction or the devices themselves could become damaged in the worst case situation. In addition, those devices should be located at least 1 m away from each wall of the booth to minimize blots.

### 4.3 Installation of Control Panel

The control panel for the automatic electrostatic air spray gun does not have an explosion-proof structure; it should be installed as described below.

① Installation location

- Outside the coating booth.
- Free from paint sprays.
- Free from direct sunlight, vibrations, and rainwater.
- Use of the standard length of the connection cable + extension cable (Max. 30 m long) ensured.

② Mounting method

- Wall-mounted
- Self-supported  Either
- Easily accessible.

If you fabricate a mounting frame, use an equal angle bar 5 x 40 x 40 or larger.

## CAUTION

Use an electric wire with the thickness of 3.5 mm<sup>2</sup> or more as a grounding wire of the control panel and conduct appropriate wiring in a location where is grounded with Class D grounding (grounding resistance is 100 Ω or less).

#### 4.4 Installation of Paint Feeder and Air Control Paint Regulator

Install the paint feeder in an easily accessible place outside the coating booth. If the electric resistance value of the paint used is low, use an insulating stand to insulate the paint container, pump, and air control paint regulator mounted to the reciprocator and provide a spatial distance of 300 mm or more to the grounded object. In addition, place a grounded protective fence around the paint feeder. The paint feeder, etc. should be grounded as described below.

① If the paint has a high electric resistance value (under normal conditions)

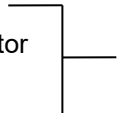
- Paint feeder
  - Air control paint regulator
  - Paint container
- 
- All must be grounded.

② If the paint has a low electric resistance value (insulating stand used)

- Insulating stand's base
  - Protective fence
- 
- Only these parts must be grounded.

#### 4.5 Electric Work

The coating booth is defined as a class 2 hazardous location containing flammable gasses; electric work should be performed in accordance with Articles 208 and 250 of the Technical Standard for Electrical Equipment.

① Electrical connection to the control panel

- 3-phase AC power line 200 V, 50/60 Hz
- Class D grounding (100  $\Omega$  or lower ground resistance)

② Connection between the control panel and reciprocator

- Reciprocator drive motor  $\phi 3$ , 200 V, 0.75 kW (explosion-proof (increased safety) type)
- Paint cut limit switch 15 V (explosion-proof (intrinsic safety) type)

③ Connection between the static electricity controller and protector

- Coating booth door switch 15 V (explosion-proof (intrinsic safety) type)
- Coating booth high-voltage indicator lamp 200 V, 40 W or lower

④ Interlocking with the conveyor

- Conveyor interlocking contact receiving terminal contained (The conveyor interlocking contact needs to be procured by the user; NO (normally open) contact, no voltage)

⑤ Connection of the connection cable

- If you lay the cable from inside the coating booth to the static electricity controller outside the booth, a feed-through bushing should be used together with an insulating support, etc. to prevent the connection cable from bending and protect it from rubbing against other objects during reciprocator operation.
- When inserting the connection cable into the static electricity controller's input terminal, wipe the metal socket carefully with a dry cloth and make sure that it is free from foreign matter such as moisture or dirt; then firmly tighten the nut.

## 4.6 Air Piping Work

Good quality compressed air containing little or no foreign matter, such as dust, oil mist, or moisture, should be used. To minimize pressure loss between the compressor and control panel, a 3/4B inch or larger steel pipe must be used.

- ① Connect the mist separator and the attached air filter to the control panel's air inlet port.

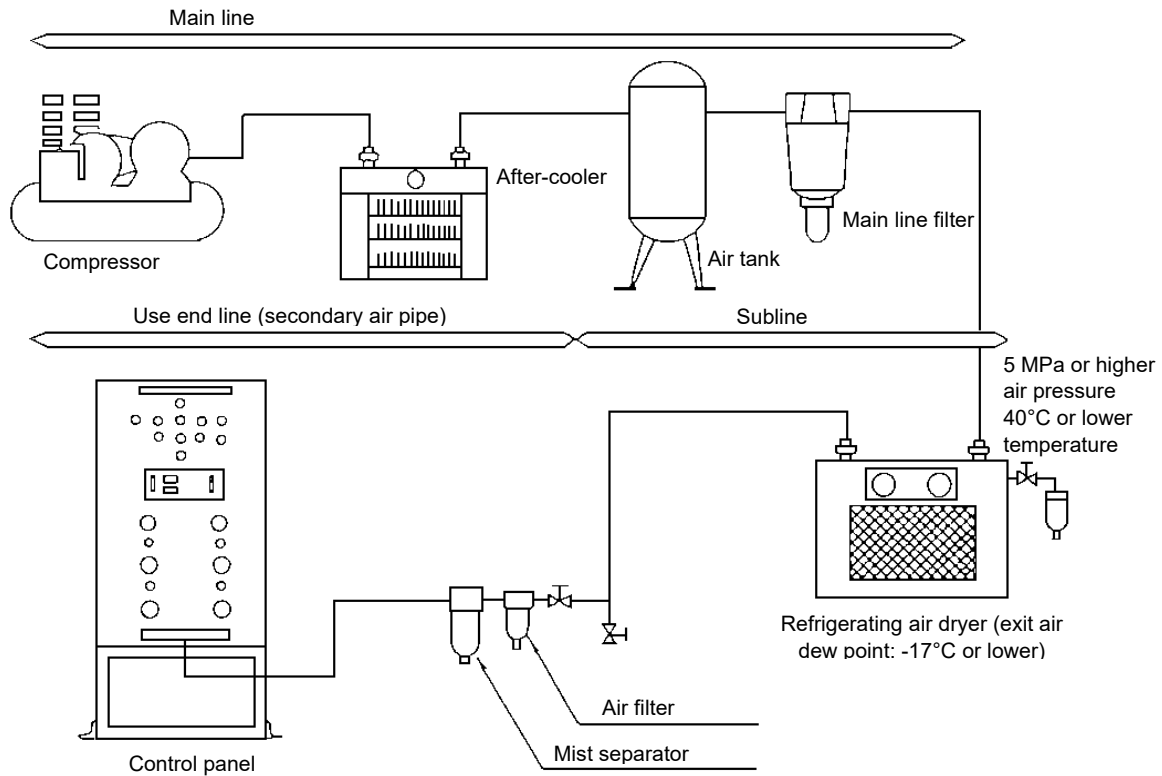

- ② When connect the pipe from the compressor to the stop valve, use a T-piece to raise the branch pipe from the main pipe; then lower it to its original position.
- ③ Connect the air hose from the coating equipment to the control panel's air outlet port (connection bore diameter:  $\varnothing 8$ ).
  - If you lay the hose from the inside of the coating booth to the outside of the booth, a feed-through bushing or an insulating support should be used.
  - Make sure that the hose is long enough to prevent it from being exposed to excessive tension or bending force during reciprocator operation.
  - Hold the hose in place with an insulating support to prevent the hose from bending and protect it from rubbing against other objects during reciprocator operation.
  - Connect the TAOP air hose (from the rear of the automatic electrostatic air spray gun) to the source of air for opening/closing the paint valve.
  - Connect the AA air hose (from the rear of the automatic electrostatic air spray gun) to the source of atomizing air.
  - Connect the PA air hose (from the rear of the automatic electrostatic air spray gun) to the source of pattern air.

This solenoid valve closes or opens when the source of air connected to TAOP is opened or closed, respectively. Therefore, a 5-port solenoid valve can be used for this purpose.

- ④ Connect the air hose from the air control paint regulator to the control panel's air outlet port.
  - Connect the paint discharge rate adjusting air hose from the air control paint regulator to the source of air for paint discharge rate adjustment.
- ⑤ Connect the air hose from the paint feeder to the control panel's air outlet port.
  - Connect the air hose from the paint opening/closing valve of the paint feeder to the paint circulator.
  - If equipped with an automatic electric discharge mechanism:
    - Connect the air hose from the upper part of the automatic electric discharge mechanism to automatic electric discharge mechanism A.
    - Connect the air hose from the lower part of the automatic electric discharge mechanism to automatic electric discharge mechanism B.

#### 4.7 Paint Piping Work

The paint hoses are used to deliver paint with high voltage applied; they should be connected using a feed-through bushing and/or an insulating support to prevent them from coming in contact with other objects.

- ① Connect the return hose from the paint pump to the paint container (connection bore diameter: PF1/4).  
In the case where air bubbles in the paint cause any disadvantages to coating operations, lengthen the return hose so that it comes close to the bottom of the paint container.
- ② Connect the paint feeder to the air control paint regulator.
  - If the paint has a high resistance value (higher than 20 MΩ·cm, insulating stand not used):
    - Use a double-layered hose for conductive paint as the paint hose.

If the paint has a high viscosity  
If a high discharge rate is required  or

Minimize the length of the hose between the paint feeder and air control paint regulator. In addition, supply paint to the air control paint regulator through the two circuits that branch from the paint pump's discharge port; or supply paint to each automatic electrostatic coating equipment with a branch from the air control paint regulator.
  - If the paint has a low resistance value (20 MΩ·cm or lower, insulating stand used):  
Take the same precautions as described above.
- ③ Connect the automatic electrostatic coating equipment and paint feeder to the air control paint regulator.
  - If you lay the hose from the inside of the coating booth to the outside of the booth, take the same precautions as in the case of an air hose.
  - Connect the paint hose from the front of the automatic electrostatic air spray gun to the air control paint regulator.
  - Connect the paint hose from the air control paint regulator to the paint feeder. If you lay the hose from the inside of the coating booth to the outside of the booth, take the same precautions as in the case of an air hose.
  - Connect the paint hose from the front of the automatic electrostatic air spray gun to the paint feeder. If you lay the hose from the inside of the coating booth to the outside of the booth, take the same precautions as in the case of an air hose.
- ④ Attach the paint nozzle to the coating equipment.  
Make sure that all the necessary hoses have been connected and then attach the nozzle.  
When attaching it, great care must be taken not to cause damage to its spraying part.

#### 4.8 Installation of Air Cap

- (1) Secure the air cap to the nozzle with your hands.

Be careful not to bend the electrode pin with the air cap.

Point the tip of the gun down so that thinner and solvent will not enter the inside of the gun.

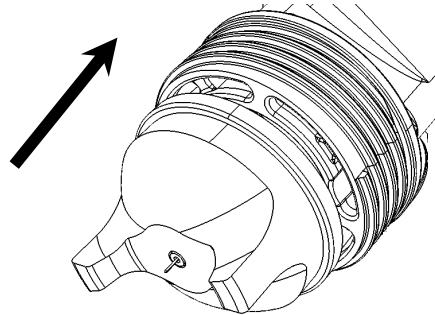

- (2) Insert the retaining nut ASSY from outside the air cap.

- ① Tighten the retaining nut ASSY until it becomes hard to rotate and align the corner of the air cap with the pattern forming direction.
- ② Tighten the retaining nut ASSY further until the air cap is secured.

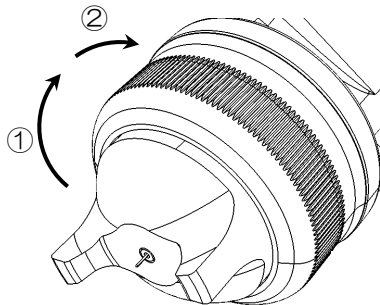

### CAUTION

This operation may cause injury to the human body and/or damage the electrode pin.  
Be sure not to touch the electrode pin when you install the air cap to the gun.

### CAUTION

The equipment may be damaged.  
Since this is a resin product, if it is tightened too much, the inside screw of the nozzle mounting joint may be damaged. Be careful when you install the air cap.

## 4.9 Inspections

After completion of installation, refer to the installation completion check list and inspect each device. If you find any problems, make adjustments or modifications immediately.

### ① Inspections and adjustments before power on

- Distance between nozzle and work piece subject to coating/side wall.
- Make sure that all the necessary grounding operations have been performed.
- Check the hoses for correct bundling. Check the connections for tightness.
- Make sure that there is no grounded object within a radius of 300 mm from the air control paint regulator.
- Check the level of oil in the oiler.
- Others. Refer to the check list and check the operation of each device.

### ② Inspections and adjustments after power on

- Check the mounting location of the reciprocator's paint cut limit switch and the adjustment of the rotary drum.
- Check the hoses, etc. for excessive tension or bending.
- Check the operation of the safety circuits and their adjusted values.
- Others. Refer to the check list and check the operation of each device.

# 5

## Precautions before Operation

The Sungun III system was designed with particular emphasis on safety. However, it is intended for use in a place containing flammable gasses. Great care must be taken when handling/operating it.

### WARNING

- Make sure that the work piece subject to coating is constantly grounded.  
(If object is metal, under 1 k $\Omega$ , and if object is plastic, under 1 M $\Omega$ .)  
However, if any paint adheres to its contact area with the hanger, its conductivity may lower and a lot of electrostatic energy could be accumulated, resulting in a fire due to a spark. Remove any paint from hangers at regular intervals.
  - All metal objects inside the coating booth must be grounded.  
High voltage is applied inside the coating booth. If any metal object fails to be grounded inside the booth, electrostatic energy could be accumulated, resulting in a fire due to a spark.
  - Do NOT bring the work piece subject to coating in contact with the nozzle attached to the automatic electrostatic air spray gun.  
If the work piece subject to coating is not correctly suspended, or if it approaches the nozzle due to vibration of the conveyor, a fire may be induced by a spark. In particular, if an insulating stand is used, intense sparks will occur; provide a large enough distance for spraying.
  - If using an insulating stand, the paint feeder must be located at least 300 mm away from the other objects around it.  
A low electric resistance paint conducts as much electricity as a copper wire does. If the paint used comes in contact with a metal object such as the paint container, you may encounter an electrical shock. If the automatic electrostatic coating equipment is located near the walk space, a grounded safety fence should be provided.
  - Wear antistatic shoes (approx. 1 M $\Omega$  electric resistance) throughout operations.  
If you wear rubber soled or synthetic resin soled shoes, you may encounter an electrical shock when you touch a grounded object.
  - Make sure that the ventilation system is in operation during paint spraying.  
Paint and solvent are subject to the hazardous materials regulations of the Fire Defense Law (they are designated as class 4 hazardous materials). The gasses generated by paint spraying are defined as explosive gasses (explosion class 1) under the factory explosion proof guideline. Operations must be performed with an appropriate ventilation system in operation.
  - Do NOT leave paint nor solvent unattended in the coating booth.  
Paint and solvent are subject to the hazardous materials regulations. They must be stored in a cabinet that conforms to the regulations. In particular, cleaning solvent must be stored in a grounded, lidded container.
- Provide a fire extinguisher.  
Be sure to keep a powder type, carbon dioxide fire extinguisher handy in case of emergency.

# 6

## Preparation for Coating

Before starting the coating operation, make preparations for coating in accordance with the following procedures.

### CAUTION

Check that the power switch of the static electricity controller is OFF.

#### 6.1 Paint

##### ① Mixing of paint

This equipment can obtain an electrostatic effect from almost all synthetic resin paints, except some paints, and therefore there is no need to mix paints specially. Meanwhile, you can obtain a higher electrostatic effect by adjusting the electric resistance value of the solvent in some cases. In addition, much electrostatic effect cannot be expected from some paints with extremely low or high electric resistance value. Check the resistance value using a paint resistance meter.

If the paint resistance value is adjusted within 15 to 70 MΩ·cm, a fair effect can be obtained in most cases. When the resistance is 15 MΩ·cm or lower, even if a fair electrostatic effect is obtained, if the booth is not ventilated properly, paint is sprayed back to the gun.

### NOTICE

You can judge if an electrostatic effect is good or bad by coating a φ20 to 30 mm steel pipe from the front as it is grounded. If coating is done up to the back side, it indicates that a good electrostatic effect is obtained.

### CAUTION

From conductive paints such as metallic paint and water paint of which electric resistance is extremely low, almost no electrostatic effect can be expected unless a paint supply system using an insulation stand.

When this kind of paint is used, the high voltage shutdown circuit of the static electricity controller is activated upon application of high voltage, and an alarming buzzer goes off and high voltage is shut down. When you turn OFF the power switch of the static electricity controller, the alarming buzzer is reset.

### CAUTION

Be sure to use a paint and solvent of which flash point higher than the room temperature by 5°C or more and turn on the ventilation system.

### NOTICE

If you do not know the compatibility between the gun/equipment and paint, please consult our company.

② Insertion of paint

Insert paint into the paint feeder.

The standard viscosity when this coating equipment is used is around 9 to 30 sec/FC#4 in general, but the viscosity varies according to various conditions such as the type of paint and solvent, shape of the work piece subject to paint spraying, and thickness of a coating film, etc.

③ Supply of paint (For the operation, see the instruction manual of your paint feeder.)

If there is any residual air in the paint hoses, spraying performance will not stabilize due to inefficient spraying; remove any air from the hoses.

④ Discharge of paint

Discharge paint from the tip of the gun. Turn ON the paint valve without supplying air to the gun to discharge paint from the tip of the gun. If there is any residual air in the paint hoses, spraying performance will be deteriorated; discharge paint until all air is removed from the hoses.

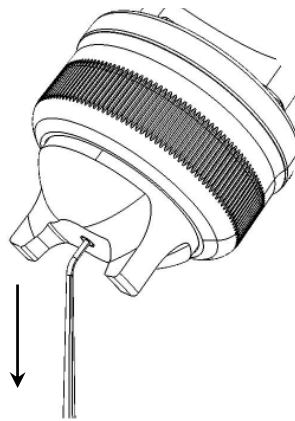

⑤ Adjustment of the quantity of paint sprayed

Set the operation mode selector switch on the control panel to "Manual," set the open/close paint switch to "On," and increase the air regulator pressure for adjustment of the quantity of paint sprayed. Adjust the quantity of paint sprayed to the specified level while paint flows from the nozzle.

If a low-viscosity paint is sprayed in small quantities, insertion of an orifice (separately sold) between the automatic electrostatic air spray gun system and nozzle will facilitate adjustments.

## 6.2 Adjustment of Air

### ① Adjustment of atomizing air

Check the atomization state of paint discharged from the gun.

Open the trigger valve and set the air pressure to be supplied to the gun to 0.2 to 0.3 MPa (target) to atomize paint.

To adjust the atomizing air pressure, set the operation mode selector switch on the control panel to "Manual" and set the atomizing switch to "On," and operate the atomizing air pressure regulator at the bottom of the control panel. Adjust it while the air cap discharges air.

While the atomization air pressure is within 0.05 to 0.35 MPa in general when using a flat spray nozzle, adjust the air pressure in accordance with the air cap and target finishing state.

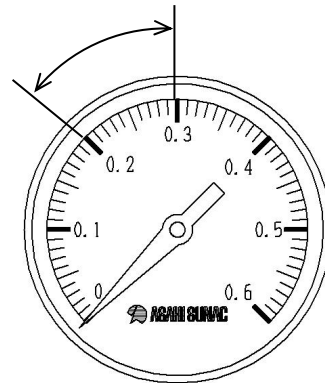
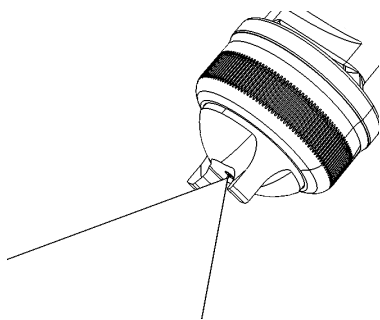

### ② Adjustment of pattern air

Adjust the pattern width of the atomized paint.

To adjust the pattern change air pressure, set the operation mode selector switch on the control panel to "Manual" and set the atomizing switch to "On," and operate the pattern change air regulator at the bottom of the control panel. Adjust the spray pattern width while spraying paint.

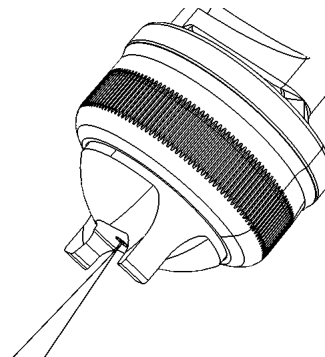
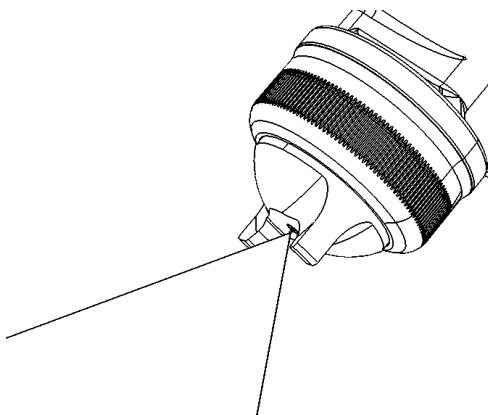

### 6.3 Spraying Distance

The spraying distance should be 150 mm or more between the tip of the nozzle and the work piece subject to paint spraying when they are located closest to each other and the coating equipment should be located ahead of the front of the reciprocator.

If the distance is too large, adhesion performance will lower. Conversely, if it is too small, sparks may be generated.

The optimum spraying distance is 250 to 300 mm.

### 6.4 Travel Speed

The travel speed of the reciprocator depends on the required coating film thickness. In general, it ranges from 15 to 45 m/min.

If the required coating film thickness cannot be obtained even at a higher speed than 50 m/min, some extra automatic electrostatic air spray guns or some extra paint heaters should be added (Use the paint at temperatures 40°C or lower). In such cases, please contact our Coating Engineering Department. (If the travel speed is increased, transfer efficiency will lower; it is not recommended).

### 6.5 Paint Spray Cut

The reciprocator stroke is kept at a constant level. Prevent unnecessary paint from being sprayed in consideration of the length or width of the work piece subject to paint spraying.

To adjust the spray cut, change the setting on our reciprocator control panel as seeing the spray state.

### 6.6 Voltage Applied

Electrostatic pressure should be adjusted in consideration of the material of the work piece subject to paint spraying as well as of the type of the paint used. In general, it ranges from approximately -50 to -70 kV. It ranges from approximately -40 to -60 kV, -30 to -50 kV or -40 to -90 kV in the case of a metallic paint, a water-based paint or a wooden product, respectively.

### 6.7 System Operation Procedures (they differ according to the specifications of the system; Operation procedures with standard specifications are described below.)

#### ① Manual operation

- Turn on the power. Set the breaker inside the panel and make sure that the "Power" indicator lamp is on. If a door switch is used, make sure that it is closed.
- Set the operation mode selector switch to "Manual." Check the "Manual" indicator lamp.
- Set the operation mode selector switch to "Coating."
- Discharge atomizing air and pattern change air. Set the atomizing switch to "On." Make sure that the "Atomizing" indicator lamp is on.
- Discharge paint. Set the paint switch to "On." Make sure that the "Paint" indicator lamp is on. Use the air regulator at the bottom of the control panel to adjust the atomizing air pressure, pattern change air pressure, and quantity of paint discharged.

- Press the "Start" switch for the reciprocator. Make sure that the "Reciprocator" indicator lamp is on.
- Supply high-voltage power.

Set the controller power switch at the central front of the control panel to "On." At this point, make sure that the controller's power lamp (green) is on. Next, press the high-voltage pushbutton switch "On" at the upper front of the control panel.

At this point, make sure that the "High pressure" indicator lamp and the controller's high pressure lamp (red) are on.

- Start coating operations.

## ② Automatic operation

- Turn on the power. Set the breaker inside the panel and make sure that the "Power" indicator lamp is on. If a door switch is used, make sure that it is closed.
- Set the operation mode selector switch to "Automatic."
- Set the operation mode selector switch to "Coating."
- Make sure that the atomizing switch is "On."
- Make sure that the paint switch is "On."
- Press the "Start" switch for the reciprocator. Make sure that the "Reciprocator" indicator lamp is on.
- Supply high-voltage power. Set the controller power switch at the central front of the control panel to "On."

At this point, make sure that the controller's power lamp (green) is on. Next, press the high-voltage pushbutton switch "On" at the upper front of the control panel. At this point, make sure that the "High pressure" indicator lamp and the controller's high pressure lamp (red) are on.

- Start coating operations.

## 6.8 Precautions to Be Taken at Stoppage and End of Spraying Operations

### ① Cleaning the paint nozzle

When stopping spraying operations, or at the end of spraying operations, be sure to clean the nozzle.

- Press the high-voltage pushbutton switch "Off" to turn off the high-voltage power.
- Bring the reciprocator to a stop to turn off the paint and air spray.
- Bring the ground bar connected to the tip of the paint nozzle in complete contact for more than 10 seconds to thoroughly discharge any residual electrostatic energy.
- Use a brush soaked (horsehair/animal/vegetable bristle brush) with solvent to dissolve and remove the paint attached to the nozzle surface.

If paint cannot be removed with the brush, submerge the nozzle in solvent for a few minutes and then retry to remove it carefully with the brush without causing damage to the nozzle.

- After it has been cleaned, discharge atomizing air manually to remove any solvent trapped in the air line.

② Cleaning the paint hoses, automatic electrostatic coating equipment, and air control paint regulator

In the case of paint color change, or if you are not using the coating equipment for a long period of time, clean the inside of the paint line.

- Press the high-voltage pushbutton switch "Off" to turn off the high-voltage power.
- Bring the reciprocator to a stop to turn off the paint and air spray.
- Set the operation mode selector switch to "Cleaning."
- Select the manual mode and operate the paint pump with no load to remove any residual paint from the paint line (use of pressurized air will help finish this operation in a shorter period of time).  
At this point, make sure that the high-voltage power is turned off.
- Open the pump's three-way cock to remove any residual paint from the paint hoses, air control paint regulator, and automatic electrostatic coating equipment. After the removal, close the cock.
- Transfer the suction pipe from the paint pump to the solvent tank and circulate solvent through the paint line without allowing it to flowing from the tip of the automatic electrostatic coating equipment (perform this step a couple of times using clean solvent).
- If you are not using the coating equipment for a long period of time, completely remove any residual solvent from the paint line; or thoroughly fill the paint line with clean solvent.
- Wipe any dirt from the surface of each equipment using a cloth soaked with solvent. Do NOT clean inside of the gun with its shroud removed.

## WARNING

- When cleaning the nozzle, make sure that the high-voltage switch is OFF.
- In the case of a paint with a low electric resistance value, be sure to use an insulating stand. Otherwise, the expected electrostatic effect could not be obtained. In general, an insulating stand should be used, if the electric resistance value of the paint is  $20 \text{ M}\Omega \cdot \text{cm}$  or lower with the voltage setting = -70 kV, or if the reading on the high-voltage generator's ammeter is  $-50 \mu\text{A}$  or higher.
- Operators must maintain a distance of more than 1 m from the coating equipment during spraying operations. If you move closer to the coating equipment, you may get an electrical shock.
- Do NOT put solvent containers inside the coating booth.

## CAUTION

- A nozzle is an essential part of a coating system. When handling nozzles, great care must be taken so as not to drop them or cause damage to them.
- Be sure to drain the air compressor once a day.  
Replace the cartridge elements for the air filter and the mist separator once every 6 to 12 months.
- Paint must be filtered before use.
- Do NOT use the gun with its shroud removed.
- If a two-component paint or an easily precipitable paint is used, thoroughly clean the inside of the gun to remove any residual paint after use.  
If it fails to be thoroughly cleaned, the durability of the bellows in the valve may lower and paint leakage could occur as a result.

## Definition of an Overcurrent

The high-voltage charging part of the coating equipment is protected with an insulating material. If its insulation performance lowers due to foreign matter, such as paint, adhered to its surface, current may flow from the high-voltage charging part through the paint adhered to the surface, resulting in a dangerous situation such as occurrence of a spark. This is a typical process of occurrence of an overcurrent.

Current leaking from the high-voltage charging part is monitored by an overcurrent protection circuit. If the current setting is exceeded, the overcurrent protection circuit will bring the output from the high-voltage generator to a stop to prevent accidents due to electrostatic energy. The activation of this circuit is regarded as an overcurrent.

If an overcurrent occurs, necessary safety measures including alarm output and coating line stoppage will be taken. To return to normal operation, you will have to restore the insulation as well as to locate the part(s) with poor insulation.

# 7

## Maintenance and Inspection

Keep the gun, paint hoses, and connection cables clean without affixing paint and other dirt on them.  
Be careful not to damage them with mechanical shock.

### 7.1 Procedure to Finish Operation

To stop or finish the coating operation, follow the procedures given below.

#### 7.1.1 When the operation is resumed within 24 hours

- (1) Turn OFF the power switch on the control panel.

### CAUTION

In the case of a paint with a low electrostatic resistance value ( $2 \text{ M}\Omega \cdot \text{cm}$  or less), the paint pump will be charged with high voltage. Be sure not to touch the pump while high voltage is being applied.

When you touch the pump or replenish the paint, turn OFF the static electricity controller and ground the pump with the ground bar.

- (2) Set the pressure of the air to be supplied to the gun to 0 MPa.
- (3) Set the drive air pressure of the paint pressure feed system to 0 MPa.
- (4) Discharge the paint from the tip of the gun to discharge the remaining pressure.

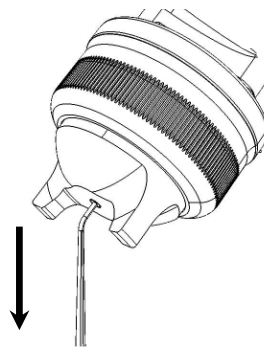

- (5) Quietly ground the electrode pin at the tip of the paint nozzle to discharge any residual electrostatic energy as the trigger is open.

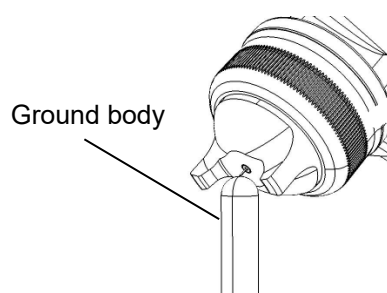

(6) Turn the retaining nut counterclockwise and remove it, and also remove the air cap.

Be careful when you remove the air cap so that thinner and solvent will not enter inside the gun.

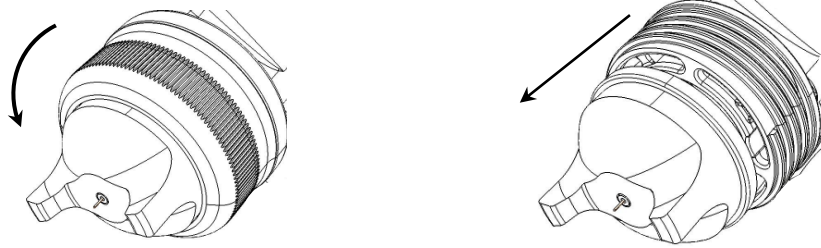

**⚠ CAUTION**

Be careful not to drop the air cap when you remove it.  
If you drop the air cap, it may get damaged.

**⚠ CAUTION**

It may cause injury to the human body and an accident.  
When you remove the air cap, be sure not to touch the electrode pin.

**⚠ CAUTION**

It may cause breakage of the retaining nut, nozzle, and equipment.  
When you remove the retaining nut, be sure to turn it with your hand.  
If you use a tool, etc. to remove the retaining nut, it may get damaged.

(7) Remove the dirt such as paint mist affixed on the gun and air cap with a waste cloth moistened with a cleaning solvent.

**⚠ CAUTION**

When you clean the gun and air cap, do not use a hard brush such as a metal brush.  
If you use a hard brush, the surface of the gun and air cap gets scratched, and their performance may be deteriorated.

## CAUTION

When you clean the nozzle and air cap, be careful so that a solvent will not enter the inside of the coating equipment. After cleaning is finished, discharge atomizing and pattern air and discharge entered solvent.

## CAUTION

Entry of solvent may cause an overcurrent during electrostatic pressure application, making it impossible to perform electrostatic coating.

Electrostatic leakage due to paint adhered to the surface of the gun may cause an overcurrent, making it impossible to perform electrostatic coating.

## CAUTION

Do not leave the gun, power cables, and hoses, etc. in a solvent while cleaning is made and after cleaning is done, or after the operation is finished. The gun contains a lot of electric and electrical circuits and has a structure in which a solvent will not enter under normal use.

However, if it leaves in a solvent for a long time, the durability may be deteriorated, causing a failure.

## CAUTION

If a chemically curing paint such as a two-component paint or an easily precipitable paint is used, clean the inside of the gun every time the operation is finished in accordance with “7.1.2 When the operation is not resumed within 24 hours”.

## WARNING

If you use the gun covered with a sheet for prevention of contamination, a spark may occur due to electrostatic pressure application, resulting in a fire.

## CAUTION

If the gun is installed in an upward inclined position, clean it while discharging atomizing air and pattern air at a low pressure of 0.05 MPa or so.

Entry of a conductive paint, such as a metallic paint, may cause electrostatic leakage, making it impossible to perform electrostatic coating.

- (8) At least once a week, remove the shroud and check its inside for foreign matter such as paint or solvent. If there is any paint inside, remove it with solvent, completely remove any residual solvent with air blows, and then attach the shroud.

### CAUTION

Do NOT perform coating operations with the shroud removed. This may cause paint mist to adhere to the inside of the shroud, resulting in an overcurrent.

Do NOT apply electrostatic pressure with the shroud removed. This may decrease the withstand voltage performance of the gun and a voltage breakdown could occur, resulting in an overcurrent.

- (9) Before the start of daily operations, make sure that the cables connected to the gun is free from damage. In addition, make sure that any excessive tension will not be applied on the cables due to the movement of reciprocator.

### CAUTION

The connection cable not only supplies power to the gun but also serves as a grounding and control wire for the gun.

If any of them are damaged, you may encounter a fire or an electrical shock due to a ground fault.

- (10) Before the start of daily operations, make sure that the metal parts, such as the gun's mounting bracket, are correctly grounded. Measure the resistance between gun's bracket and a grounded object such as the booth; it must be 100  $\Omega$  or lower.
- (11) Before the start of daily operations, make sure that the gun is firmly secured and that the gun does not come into contact with the work piece subject to paint spraying.

#### 7.1.2 When the operation is not resumed within 24 hours

- (1) Turn OFF the power switch on the control panel.
- (2) Set the pressure of the air to be supplied to the gun to 0 MPa.
- (3) Pull out the suction pipe of the paint pump from the paint container.
- (4) Drive the paint pump and discharge the paint from the paint return line.
- (5) Open the trigger valve of the gun to discharge the paint remaining in the hoses and gun from the tip of the gun.
- (6) Suck a cleaning solvent from the suction pipe, discharge it from the return side to the cleaning waste container, and repeat this procedure until the inside of the pump becomes clean.
- (7) Discharge the solvent from the tip of the gun to clean the hoses and inside the gun.
- (8) Stop the pump and open the trigger valve to discharge the residual pressure from the tip of the gun.
- (9) Turn the retaining nut counterclockwise and remove the air cap.
- (10) Remove the dirt such as paint mist affixed on the gun and air cap with a waste cloth moistened with a cleaning solvent.
- (11) Rotate the hex of the nozzle using the dedicated spanner and remove the nozzle.

It is recommended to leave the cleaning solvent in the line after cleaning is finished to prevent the remaining paint in the paint line from being hardened.

 **CAUTION**

The paint nozzle may be damaged.

When you remove the nozzle, be sure to use the dedicated spanner, which is an attached part. Be careful not to drop the nozzle.

(12) Dip the paint nozzle in the cleaning solvent and blow the compression air to the nozzle to blow off the dirt.

 **CAUTION**

When you clean the paint nozzle, do not poke it with a metal object such as a wire. Do not use a metal brush and the like. If you do so, it may expand the hole diameter and/or make scratches, deteriorating the performance.

 **CAUTION**

Wait 10 sec or more after turning OFF the power switch of the static electricity controller before cleaning the gun. 90% or more of fire accidents of the static electricity coating equipment occurred upon cleaning of the nozzle, etc. When you clean the nozzle, etc., be sure to turn OFF the power switch.

Provide a fire extinguisher in case of a fire accident.

 **CAUTION**

When an error occurs during the operation, turn OFF the power switch of the static electricity controller and lower the pressure of the air and paint to be supplied to the gun to 0 MPa.

 **CAUTION**

Do not give a strong shock such as drop, etc.

Although this equipment is designed fully taking into consideration strength, it may get damaged by shock.

(13) Regarding the cleaning waste solvent, collect and reuse it using the Solvent Recovery Device or dispose it through an industrial waste disposal contractor in accordance with the law.

## 7.2 Maintenance of Other Equipment

- (1) For maintenance of the paint feeder, refer to its instruction manual.
- (2) At the end of daily operations, clean the resin portion of the air control paint regulator's mounting bracket with solvent to remove any paint.

### CAUTION

Adhesion of a lot of paint to the surface of the air control paint regulator's mounting bracket may cause charging current to leak, resulting in an overcurrent.

- (3) If a two-component paint or an easily precipitable paint is used, thoroughly clean the gun with solvent after use. Disassemble and clean it at regular intervals (at least once every three months).

## 7.3 Periodical Inspections

Conduct inspections regularly in accordance with the table in the next page so that the performance of this equipment can be fully utilized. The frequency of each inspection is a reference and varies according to the use condition.

### WARNING

Unexpected operation of the coating equipment may cause injury to the human body and an accident.

Before conducting a periodic inspection, turn OFF the power of the control panel and release air and pressure.

Item	Procedure	Frequency
Inspection of exterior of the gun	When paint is affixed on the gun, wipe it with a soft cloth or brush moistened with a cleaning solvent.	Every day
	If there is any scratch on the gun, replace the gun with a new one.	
Inspection of waste paint from air cap	When paint is affixed on the air cap, wipe it with a soft cloth or brush moistened with a cleaning solvent.	
Inspection of clogging of air cap air discharge hole	Dip the air cap in a cleaning solvent and blow it with air.	
	If clogging cannot be removed, replace the air cap with a new one.	
Inspection of scratches and dents around the paint outlet of the paint nozzle	If there is any scratch and/or dent on the paint nozzle, replace it with a new one.	
Inspection of clogging of the paint discharge hole of the paint nozzle	Dip the paint nozzle in a cleaning solvent and blow it with air to remove clogging. If clogging cannot be removed, replace it with a new one.	
Inspection of paint seat and bellows needle	Perform cleaning from the gun paint line to the nozzle by pouring a cleaning solvent, and if paint is leaked from the tip of the gun, replace the paint seat or bellows needle.	
Check current value when electrostatic pressure applied.	If the current value is higher than the normal value, identify the location where current is leaked and replace the part.	
Inspection of charge electrode	If the distance between the electrode and paint discharge hole of the nozzle is less than 2 mm, replace the electrode with a new one.	
Inspection of connection cable	If the connection cable is damaged, replace it with a new one.	
Inspection of air leakage	If air is leaked, replace the seal at the air leakage location.	Every month
Inspection of contamination with paint in paint hose	If the inside the paint hose is contaminated with paint, perform cleaning by pouring a cleaning solvent.	
	If clogged paint cannot be removed, replace the hose with a new one.	
Inspection of trigger valve	If paint leaks from the tip of the gun, replace the trigger valve.	
Inspection of piston	When there is a problem in sliding ON/OFF of the trigger valve, replace the piston with a new one.	

## NOTICE

For how to replace parts, see “10. How to Replace Parts”.

## CAUTION

Do not disassemble the gun unnecessarily when an error occurs.  
You should not disassemble the gun to maintain the electric insulation and sealing functions of the gun unless there is a need to replace a part due to an error.

## CAUTION

The surface of the gun may get warm by heat of the high-voltage generator. This is not a failure.

#### 7.4 Consumable Part

Prepare spare parts in accordance with the use condition with reference to the rank category in the consumable parts list given below.

Rank category	Part name	Parts No.	Durable period	Parent unit	Reference page
A	Paint nozzle ASSY	15F7	6 months	EAB500	40·41·48·49
	Charge electrode	1718	6 months	EAB500	41·48
	O-ring	130-9012	6 months	Paint nozzle ASSY	40·49
B	Paint seat	1726	12 months	EAB500	41·47·48·49
	O-ring	101-9005	12 months	EAB500	46·48
	O-ring	101-6024	12 months	Piston ASSY	46·49
	O-ring	130-9006	12 months	Paint seat	49
	Elastomer spring	1727-004	12 months	Bellows seal ASSY	44·49
	Bellows needle	1727-001	12 months	Bellows seal ASSY	43·44·49
	O-ring	101-9007	12 months	EAB500, Bellows seal ASSY	44·48·49
	Ring seal	373-0010	12 months	Retaining nut ASSY	49
C	O-ring	101-9006	-	EAB500	48
	O-ring	101-9010A	-	EAB500	48
	O-ring	101-9012	-	EAB500	48·49
	O-ring	130-9020	-	EAB500	48
	O-ring	130-9085	-	EAB500	48
	Hex. socket head cap screw	03-70625	-	EAB500	44·48
	Plug	1724-002/1724-003	-	Front block	43·49·50
	O-ring	130-9026	-	Front block	49
	O-ring	130-9070	-	Front block	49
D	Split pin	49-10220	-	EAB500	45·48
	O-ring	130-9004	-	Front block	43·49·50
	O-ring	130-90112	-	Paint seat	49

Rank A: Daily consumable parts

Rank B: Medium-term consumable parts

Rank C: Parts that may get damaged/lost upon disassembling

Rank D: Parts that need to be replaced upon disassembling

\*Note that the durable periods of the consumable parts vary according to the paint and facilities conditions, etc. The values given in the above consumable parts list are reference values in the case that the equipment is operated for 20 days/month and 8 hours /day.

## 8

## Paint Problems and Solutions

There are cases where multiple symptoms and causes occur at the same time according to the state of a paint problem.

Symptom	Cause	Countermeasure
1. Poor spray atomization	① The atomization air pressure is too low.	① Increase the atomization air pressure.
	② Quantity of paint discharged is too large.	② Reduce quantity of paint discharged or increase the atomization air pressure.
	③ Paint viscosity is too high.	③ Lower paint viscosity.
	④ The pin at the tip of the nozzle is bent.	④ Replace the charge electrode.
	⑤ The paint nozzle is damaged.	⑤ Replace the paint nozzle ASSY.
	⑥ The solvent is not appropriate.	⑥ Consult the paint manufacturer or us.
2. Excessive paint splashes	① The spraying distance is too far.	① The spraying distance must be within 150 to 200 mm.
	② The atomization air pressure is too high.	② Adjust the atomization air pressure to lower.
	③ The paint resistance is too low.	③ Adjust the paint resistance to within 15 to 70 MΩ · cm).
	④ Grounding of the work piece subject to paint spraying is not complete.	④ Provide complete grounding.
	⑤ The discharge speed is too slow.	⑤ Increase the discharge speed.
3. Poor coating efficiency	① Ground fault with work piece subject to paint spraying.	① Clean the paint affixed on the hanger and provide complete grounding.
	② The atomization air pressure is too high.	② Adjust the atomization air pressure to an appropriate level.
	③ The spraying distance is too far.	③ The spraying distance must be within 150 to 200 mm.
	④ Applied voltage is too low.	④ Increase the output voltage of the static electricity controller using the output voltage adjustment switch.
	⑤ The charge/discharge speed of the booth is too fast.	⑤ Adjust the charge/discharge speed of the booth to lower.
	⑥ Paint electric resistance is too high.	⑥ Adjust the resistance to within 15 to 70 MΩ · cm.
4. "Whiskers" generated due to paint attached to nozzle, or filiform lumps generated on a work piece subject to paint spraying.	① Solvent vaporizes too quickly.	① Use lower volatility solvent or additive.
	② The paint has a high viscosity.	② Lower paint viscosity.
5. Granulated paint surface	① Poor spray atomization.	① See "Poor atomization" in 1 of this chapter.
	② There is much dust in the coating booth, and dust is affixed on the paint surface.	② Put dust filter at the air intake duct leading to the coating booth and remove dust with air blows.
	③ Contamination of atomized air	③ Clean or replace the filter of the air line.
	④ Unevenly distributed pigment is contained in paint.	④ Change the solvent or filtrate the paint thoroughly.
6. Orange peel (spots/marks)	① The temperature in the paint booth is high, or the solvent evaporates fast.	① Adjust the room temperature or use lower volatility solvent.
	② Temperature of work piece subject to paint spraying is too high.	② Adjust the drying furnace to lower the temperature of the work piece subject to paint spraying.
	③ The charge/discharge speed is too fast.	③ Adjust the speed in the range from 0.5 to 1.0 m/s on the surface of the work piece subject to paint spraying.

Symptom	Cause	Countermeasure
7. Crawling	① Incompletely cleaned work piece subject to paint spraying.	① Perform cleaning thoroughly or remove oil thoroughly.
	② Contamination of atomized air	② Clean or replace the filter of the air line.
	③ Baking oven exhaust failure.	③ Make exhaust system operate correctly.
8. Sagging of paint on the paint surface	① Coating film is too thick.	① Reduce the paint discharge amount or increase the gun travel speed.
	② Paint viscosity is too low.	② Increase paint viscosity.
	③ Solvent vaporization is slow.	③ Use higher volatility solvent.
9. See-through of coating film	① Insufficient paint is discharged.	① Adjust the quantity of paint sprayed and consider the travel speed of the gun and recoating.
	② Paint viscosity is too low.	② Increase paint viscosity.
10. Pinholes	① Contamination of atomized air	① Clean or replace the filter of the air line.
	② Solvent vaporizes too quickly.	② Use lower volatility solvent.
	③ Temperature of work piece subject to paint spraying is too high.	③ Lower the temperature.
	④ Incompletely dried undercoating.	④ Completely dry.
	⑤ Setting time is short.	⑤ Take sufficient setting time.
11. Blushing (whitening).	① Temperature and humidity inside and outside of the paint booth are high.	① Use lower volatility solvent. Inspect air-conditioning equipment.
	② Inappropriate solvent selected.	② Consult the paint/solvent manufacturer or us.
12. Bubbles (foaming)	① Contamination of atomized air	① Clean or replace the filter of the air line.
	② Incompletely dried after wet rubbing.	② Completely dry.
	③ Coating film is too thick.	③ Reduce the paint discharge amount.
	④ Solvent vaporizes too quickly.	④ Use lower volatility solvent.
	⑤ Temperature of the baking oven is too high.	⑤ Adjust the temperature to an appropriate value.
13. Inappropriate pattern shape	① Paint and/or dust is affixed to atomized air of the paint nozzle and to the paint discharge outlet.	① Perform cleaning thoroughly using thinner and a bamboo brush and filtrate the paint.
	② The paint has a high viscosity.	② Lower the viscosity.
	③ The tip of the paint nozzle is damaged.	③ Repair or replace nozzle.
	④ Pattern adjustment failure.	④ Adjust the pattern correctly.
	⑤ Incompletely tightened nozzle.	⑤ Confirm that the paint nozzle ASSY is not loosened and then mount the air cap.

# 9

## Troubleshooting

There are cases where multiple symptoms and causes occur at the same time according to the state of a failure.

Symptom	Cause	Countermeasure
1. Paint discharge is unstable, and spray performance becomes insufficient.	① The paint nozzle ASSY is not tightened firmly.	① Tighten the paint nozzle ASSY firmly.
	② The seat face of the paint seat or bellows needle is damaged.	② Replace the paint seat or bellows needle.
	③ Air is mixed into the paint.	③ Check the paint feed system.
	④ Quantity of paint discharged is extremely low.	④ Increase the paint discharge amount or lower the atomized air pressure.
	⑤ The elastomer spring to drive the bellows is damaged.	⑤ Replace the elastomer spring.
2. The paint discharge amount is decreased.	① Failure in the paint pressure feeding system	① Check the paint pump, paint regulator, and other paint supply system.
	② Clots of paint and/or dust is clogged in the paint seat unit.	② Clean the paint seat unit.
	③ Paint and/or dust is affixed in the paint nozzle ASSY.	③ Remove the paint nozzle ASSY and clean it.
3. Paint leaks from the nozzle.	① Clots of paint and/or dust is clogged in the paint seat unit.	① Clean the paint seat unit.
	② Wear-out and chipping of the paint seat unit.	② Replace the paint seat or bellows needle.
	③ Wear-out of spring at the rear of piston ASSY.	③ Replace the spring at the rear of piston ASSY.
	④ The pressure feeding pressure of the paint is too high.	④ Lower the pressure feeding pressure.
4. Paint leaks from the leakage check hole of the gun.	① Damage of the bellows seal	① Replace the bellows needle.
	② Damage of the O-ring of paint pipe/plug	② Replace the O-ring of paint pipe/plug.
5. Unstable opening/closing of trigger valve	① Wear-out of the O-rings around the piston.	① Replace the O-rings around the piston.
	② Wear-out of spring at the rear of piston ASSY.	② Replace the spring at the rear of piston ASSY.
	③ The elastomer spring to drive the bellows is damaged.	③ Replace the elastomer spring.

Symptom	Cause	Countermeasure
6. Spark is discharged from nozzle. (When the insulating stand is not used)	① Damage of power pack	① Replace the power pack.
7. Spark is discharged from nozzle. (When the insulating stand is used)	① Damage of power pack	① Replace the power pack.
	② Paint is changed to the one with a low electric resistance value or to a metallic paint.	② Lower the output voltage of the static electricity controller.
8. Warning buzzer of the control unit goes off. (When the insulating stand is not used)	① Paint is affixed on the exterior of the gun.	① Clean the exterior of the gun.
	② Paint is affixed in the inner diameter of the paint hose.	② Clean the paint hose.
	③ Moisture is accumulated in the air line.	③ Drain water from the air line thoroughly. Turn off the static electricity controller and open the trigger valve to perform air purge to discharge water from the air line.
	④ Paint is changed to the one with a low electric resistance value or to a metallic paint.	④ Use the insulating stand.
	⑤ Paint is leaked due to damage of the bellows seal.	⑤ Replace the bellows needle.
9. Warning buzzer of the control unit goes off. (When the insulating stand is used)	① Paint is affixed on the exterior of the gun.	① Clean the exterior of the gun.
	② Paint is affixed in the inner diameter of the paint hose.	② Clean the paint hose.
	③ Moisture is accumulated in the air line.	③ Drain water from the air line thoroughly. Turn off the static electricity controller and open the trigger valve to perform air purge to discharge water from the air line.
	④ There is a grounding object near the insulating stand.	④ Place the insulating stand 300 mm or more away from the grounding object.
	⑤ Paint is affixed to the insulating bar of the insulating stand.	⑤ Clean the insulating bar.
	⑥ The section above the insulating bar of the insulating stand is grounded.	⑥ Separate the grounded section above the insulating bar.
	⑦ Paint is leaked due to damage of the bellows seal.	⑦ Replace the bellows needle.

 **CAUTION**

Do not make repairs with any methods other than those specified in this instruction manual.

Follow the procedures below to replace/repair parts.

Apply white vaseline when you mount the screw units (except the paint nozzle ASSY and retaining nut ASSY) and/or the O-ring of the sliding section shown below.

If you find any sealing part such as the O-ring of each ASSY is damaged upon disassembling, replace it as needed.

### WARNING

Unexpected operation of the coating equipment may cause injury to the human body and an accident.

Before you replace or repair a part, be sure to turn OFF the air supplied to the gun and static electricity controller and discharge the paint in the paint line and clean the paint line.

#### 10.1 Replacing Air Cap

Remove and replace the air cap in reference to “4.8 Installation of Air Cap” of “4 Installation.”

#### 10.2 Replacing Paint Nozzle ASSY

(1) Remove the paint nozzle using the flat spanner, which is an accessory tool, and replace it. When you reinstall the paint nozzle, firmly insert the nozzle to the designated position where the specified paint nozzle is recessed by approx. 1 mm from the tip end of the front block.

If the paint nozzle does not reach the designated position, a pattern adjustment failure and/or paint reversal may occur.

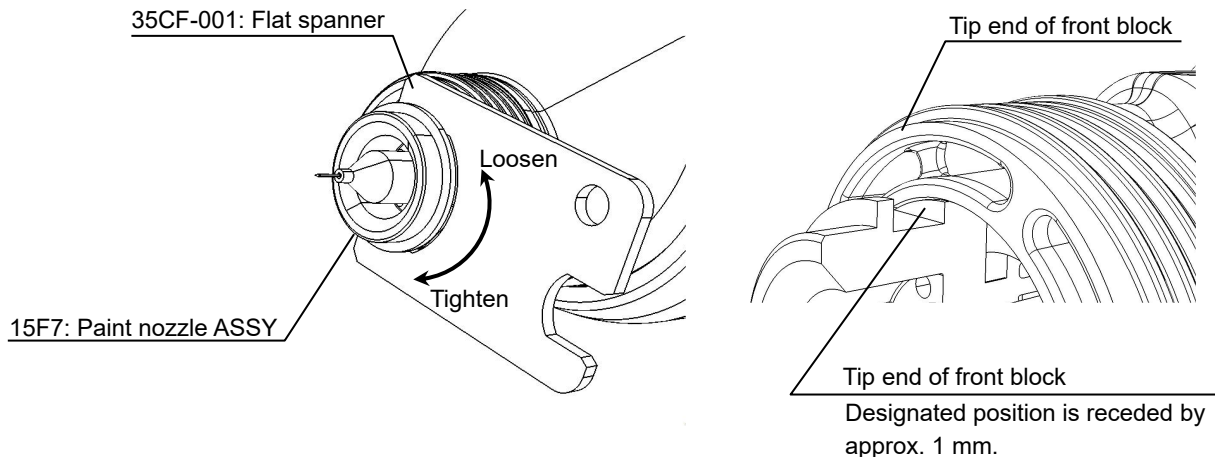

(2) If the O-ring (130-9012) is found damaged when you remove the paint nozzle ASSY, replace the O-ring.

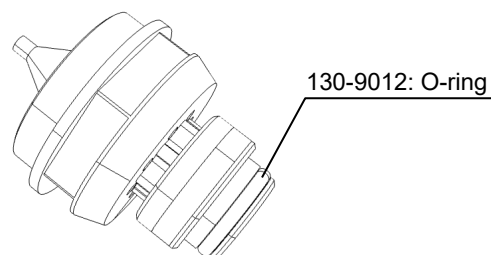

### 10.3 Replacing Charge Electrode

Pinch the spring section of the charge electrode, remove it from the detached paint nozzle ASSY, and replace it.

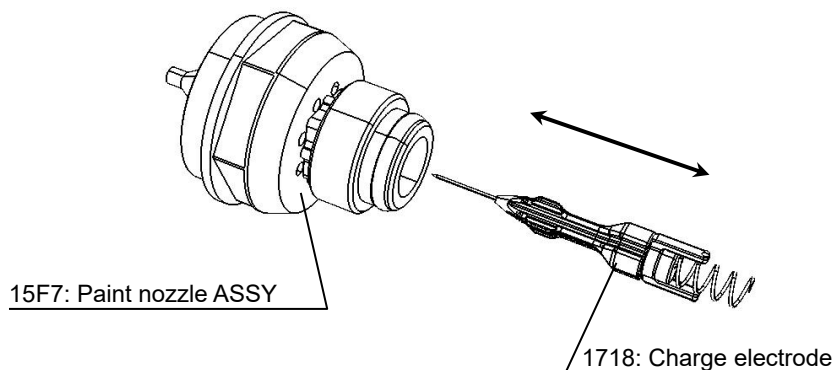

### 10.4 Replacing Paint Seat

(1) Stop the paint pump and discharge residual pressure. Remove and replace the paint seat using the box spanner as one of the attached tools as the paint nozzle ASSY and charge electrode are removed.

\*Recommended tightening torque: 200 cN·m

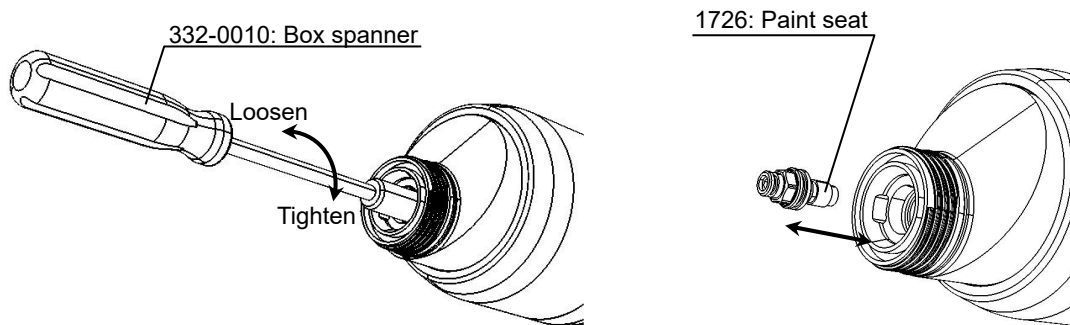

(2) When you clean the seat section of the paint seat, clean it with thinner and dry it thoroughly with air blows.

\*Do not use a metal brush, etc. to clean the seat.  
It may damage the seat, causing a seat failure.

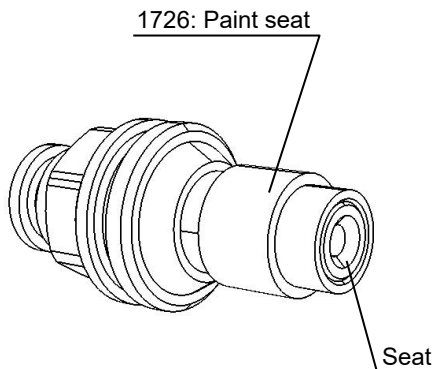

## 10.5 Removing Shroud

(1) Mount the belt wrench of the shroud and remove the shroud.

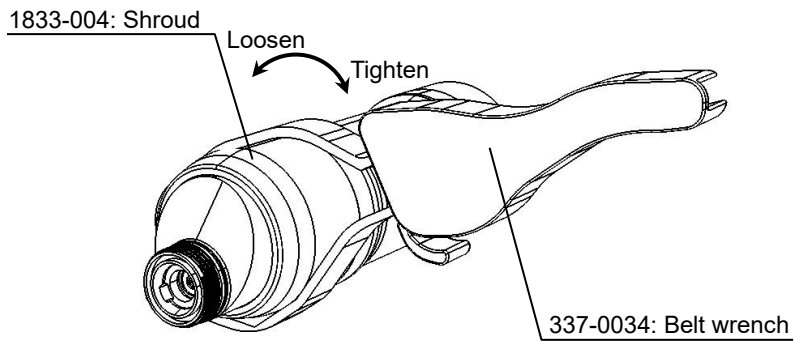

(2) When you remove the shroud, take a drop prevention measure for the front block ASSY and mounted O-ring in advance.

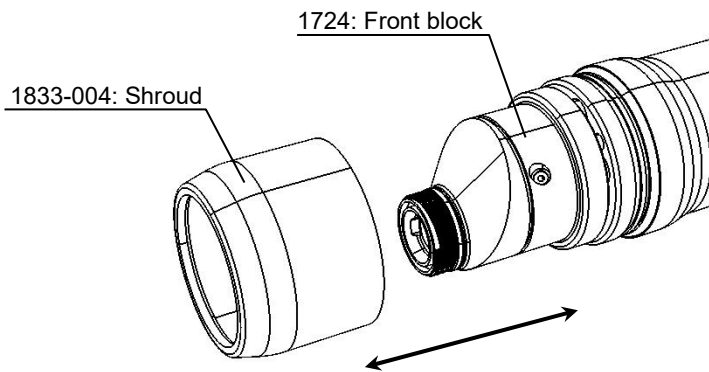

## 10.6 Disassembling Front Block ASSY

(1) Remove the front block ASSY from the rear block.

\*Since the ASSY is retained by the paint hose and pipe, you need to draw it out.

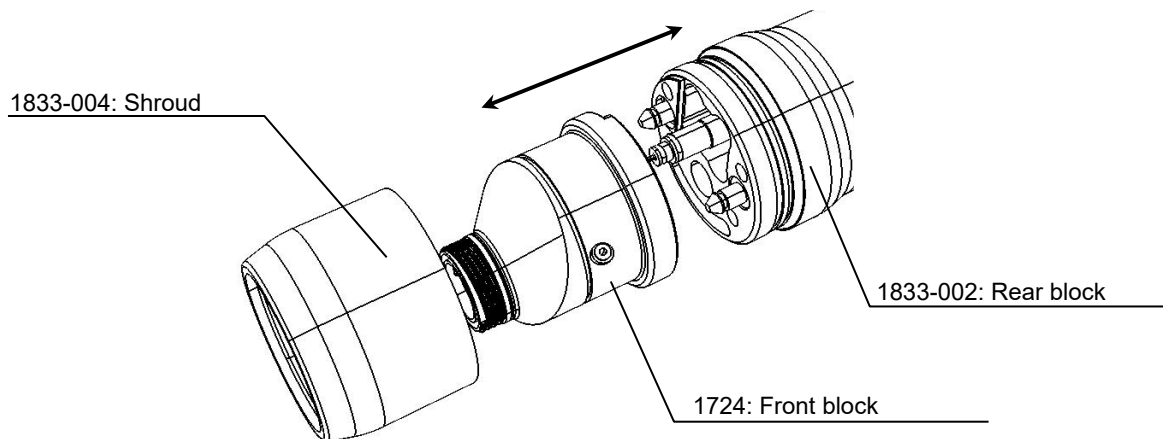

(2) When you clean the paint line in the front block, remove the plug and clean the paint line with a bar brush, etc.

When the plug is removed, replace the O-ring mounted on the plug.

\*The front block is resinous, and therefore it may be damaged if you use a metallic brush.

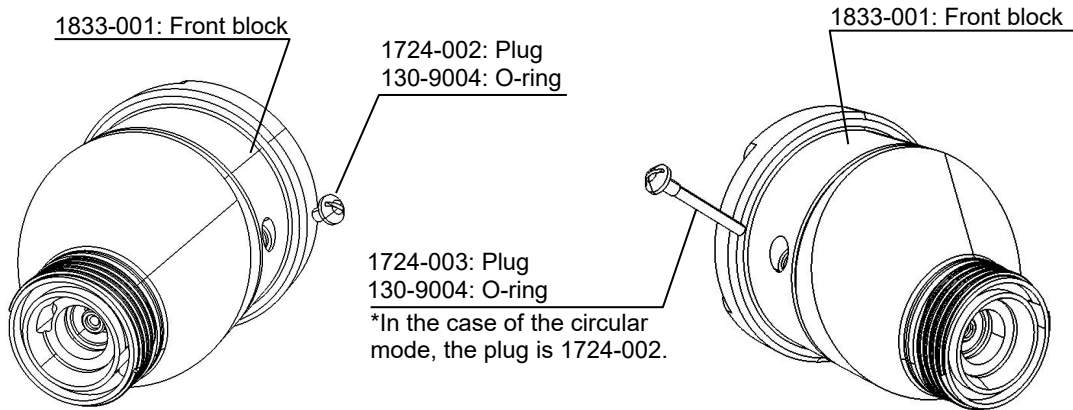

(3) Check the state of the O-rings mounted on the front block and replace a damaged O-ring, if any.

### 10.7 Disassembling Bellows Seal ASSY

(1) Remove the bellows seal ASSY from the front block using the hex 17 mm spanner.

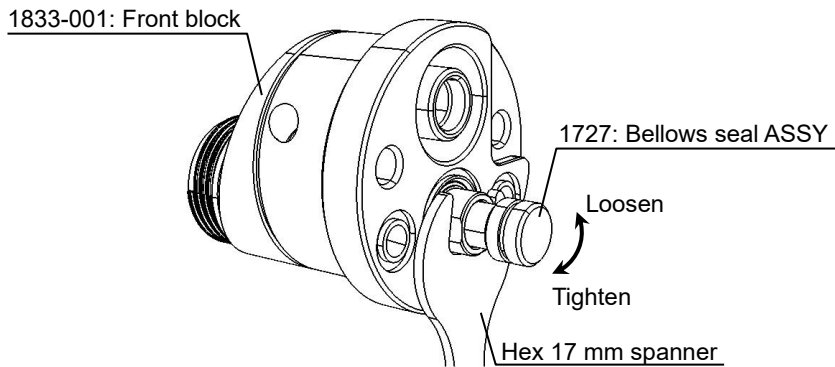

(2) Hold the bellows section of the detached bellows seal ASSY and remove the front shaft.

\*The bellows needle and front shaft are assembled with a resin screw, and therefore if you tighten it too much, the screw section may get damaged.

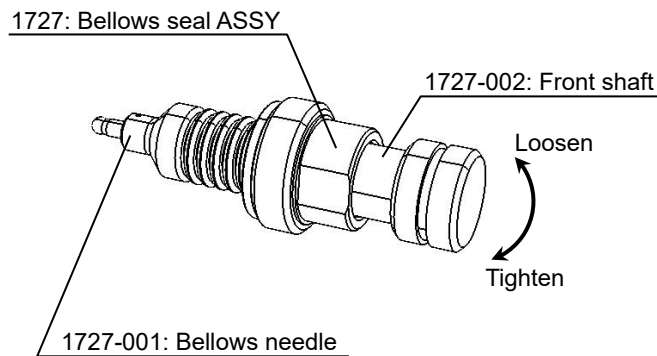

(3) Replace the bellows needle, O-ring, and elastomer spring, etc. if they are damaged.

Assemble the necessary parts as shown in the figure below and tighten the front shaft as holding the bellows needle. (Since the screw is a soft resin, you cannot sense the completion of tightening of the screw section. Tighten the shaft until the distance between the nut and front shaft becomes 8 mm as a target.)

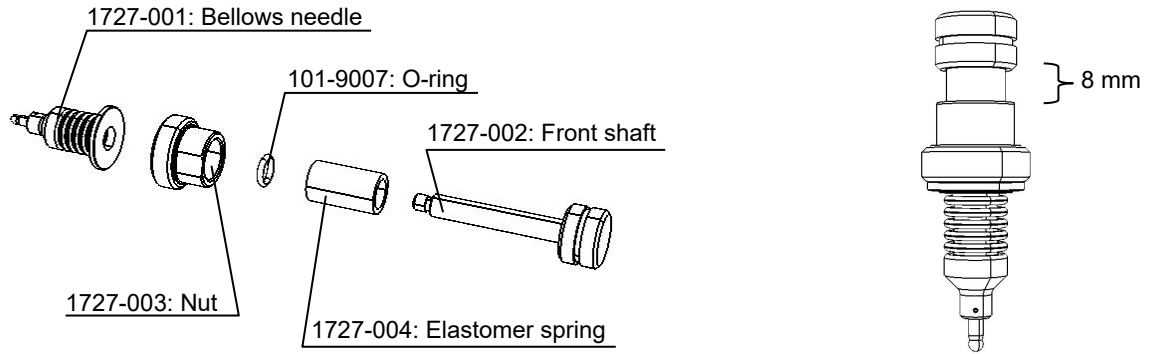

### 10.8 Removing Extension

(1) Remove the hex socket bolts (M6 x 25L) x 4 which connect the rear block and back plate using a hex 5 mm wrench.

\*When you remove the hex socket bolts, take a drop prevention measure in advance.

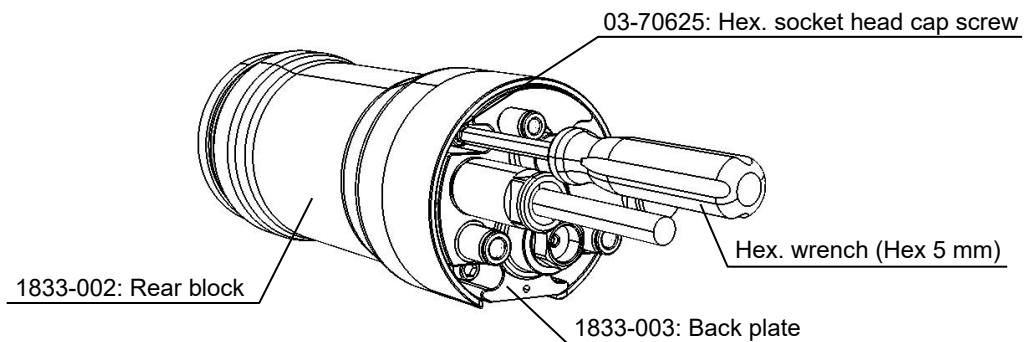

(2) Remove the rear block from the back plate after removing the hex socket bolts.

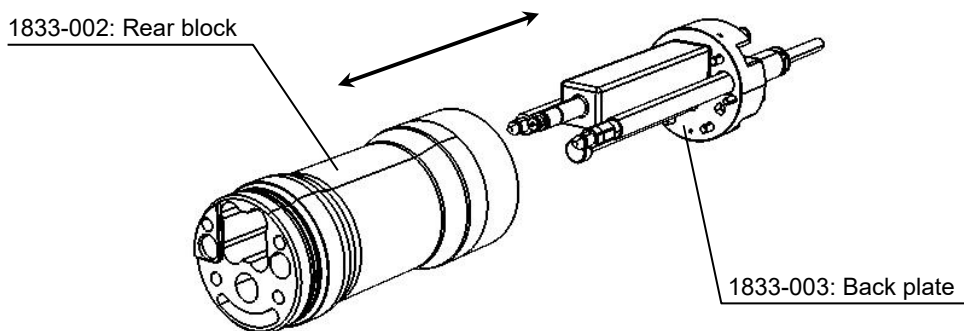

(3) Remove the power pack and paint hose/plug from the back plate after removing the rear block.

\*When you remove the power pack, remove the connection cable in advance.

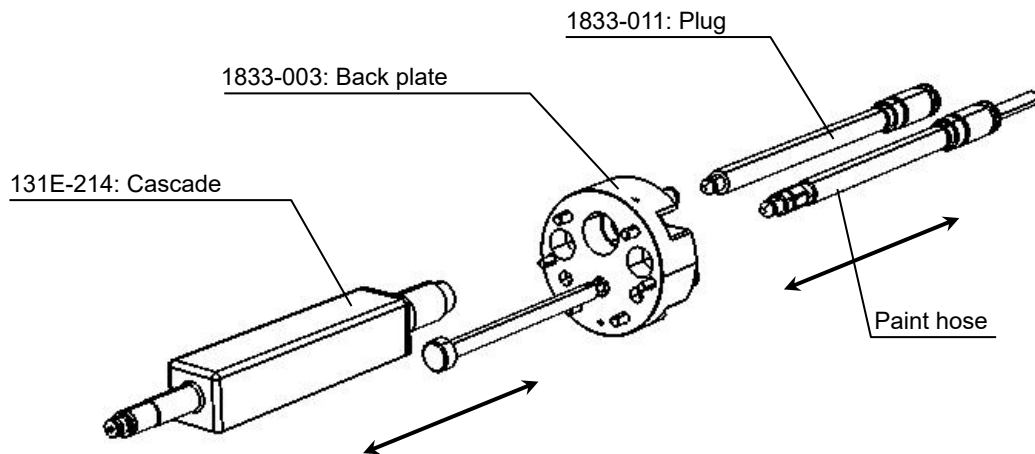

(4) Remove the split pin which secures the extension and piston ASSY and remove the extension.

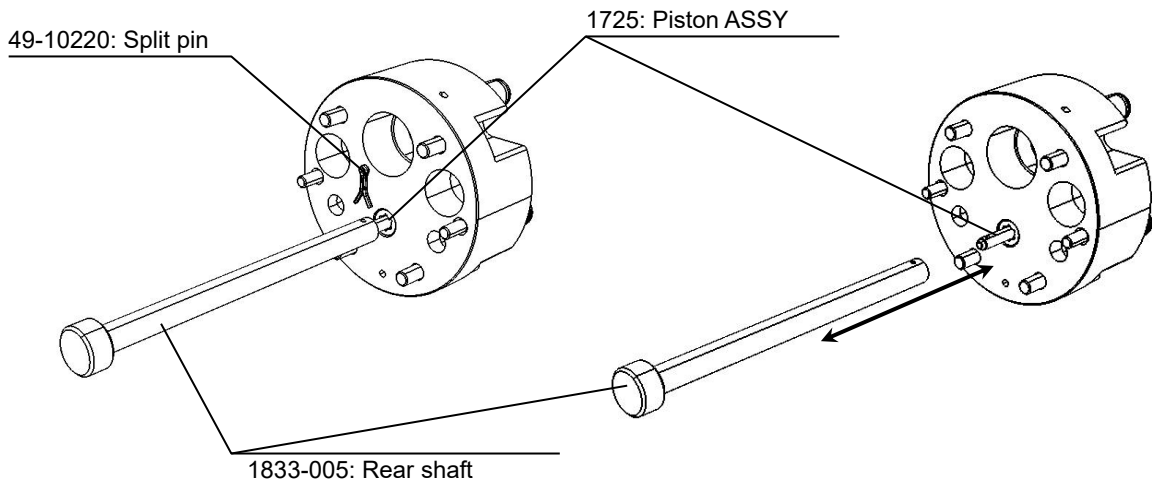

\*The split pin may be damaged when it is repeatedly detached and attached, and therefore prepare its spare part.

## 10.9 Replacing Piston ASSY

(1) Remove the cap from the back plate using the hex 19 mm spanner.

\*A spring is mounted in the cap, and therefore the cap may drop when it is removed. Be careful when you remove the cap.

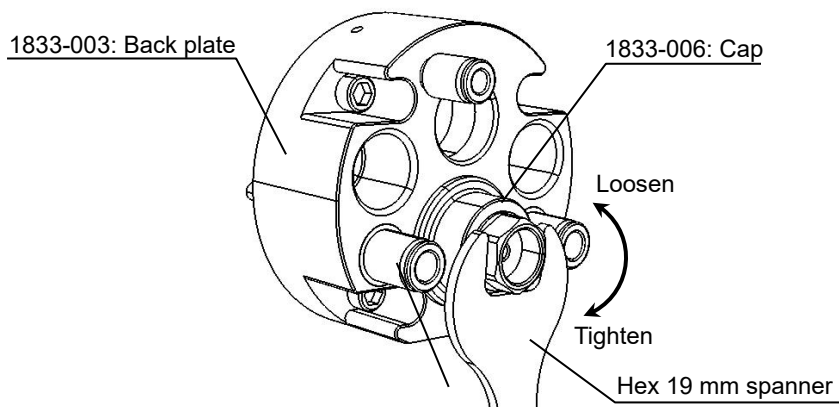

(2) After removing the cap, remove the spring and piston ASSY in the cap.

\*Since the O-ring of the piston section is a sliding seal, it is recommended to replace it when it is removed.

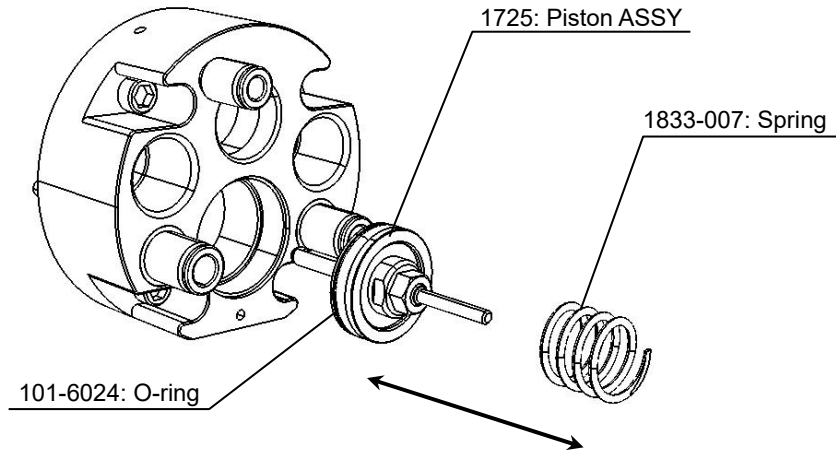

(3) Remove the cap nut mounted on the rear block using a 6 mm hex wrench. Replace the O-ring mounted inside the rear block if it is damaged.

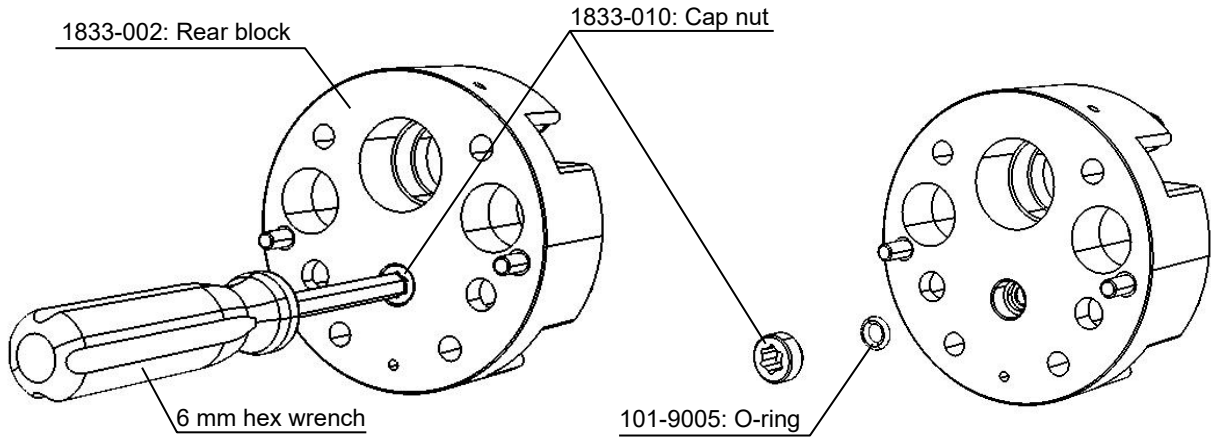

#### 10.10 Installing Paint Hose and Plug

Assemble the gun, and then install the paint hose and plug using the 17 mm hex spanner.

\*Be sure to install the paint hose and plug after the gun is assembled completely.

If they are mounted before the entire gun is assembled, the front block ASSY may not come to the designated position according to the positions where the paint hose/plug are inserted, resulting in air leakage.

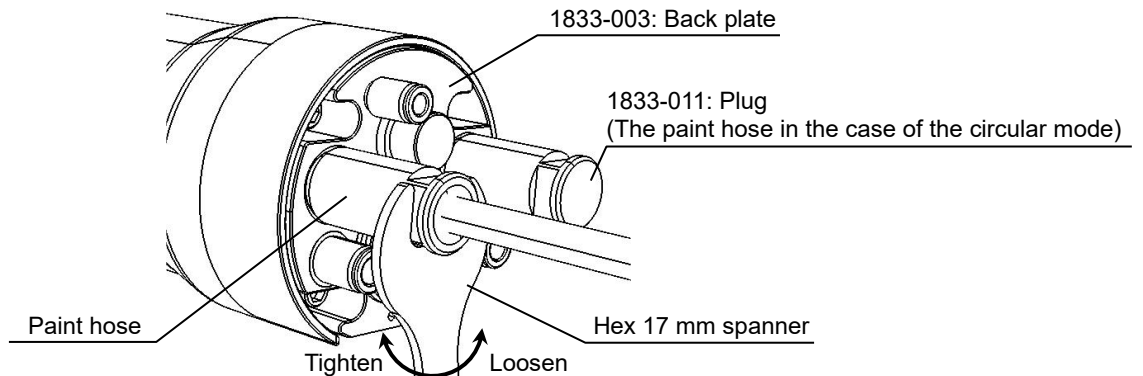

## 10.11 Installing Orifice

An orifice can be mounted on the gun as a part to adjust the discharge amount.

- (1) Insert an orifice to the specified location as the paint nozzle ASSY and charge electrode are removed.

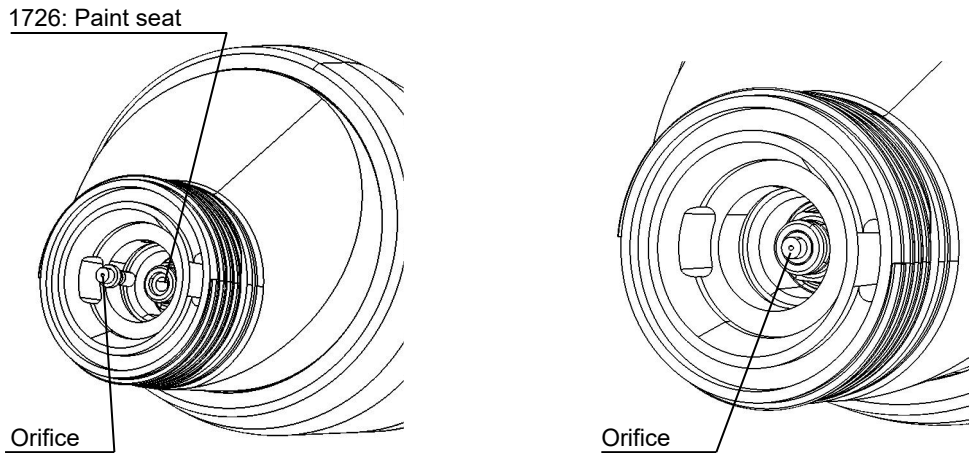

- (2) Install the paint nozzle ASSY with the charge electrode mounted as being careful not to drop the installed orifice.

- (3) While a  $\phi 0.7$  orifice (Part No.: 1832-750) is included in the initial component parts as an accessory part, select an appropriate orifice, which is sold separately, in the table below according to the usage.

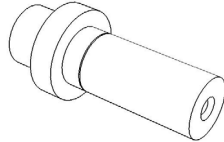
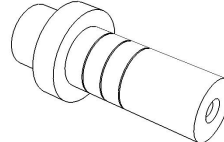
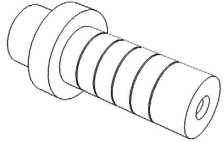
Diameter of orifice	Parts No.	How to identify	Remarks
$\phi 0.5$	1832-550	 Number of identification lines = 1	
$\phi 0.7$	1832-750	 Number of identification lines = 3	Initial component part
$\phi 0.9$	1832-950	 Number of identification lines = 5	

# 11

## Exploded Diagram and Names of Parts

### 11.1 EAB500

EAB500

1833

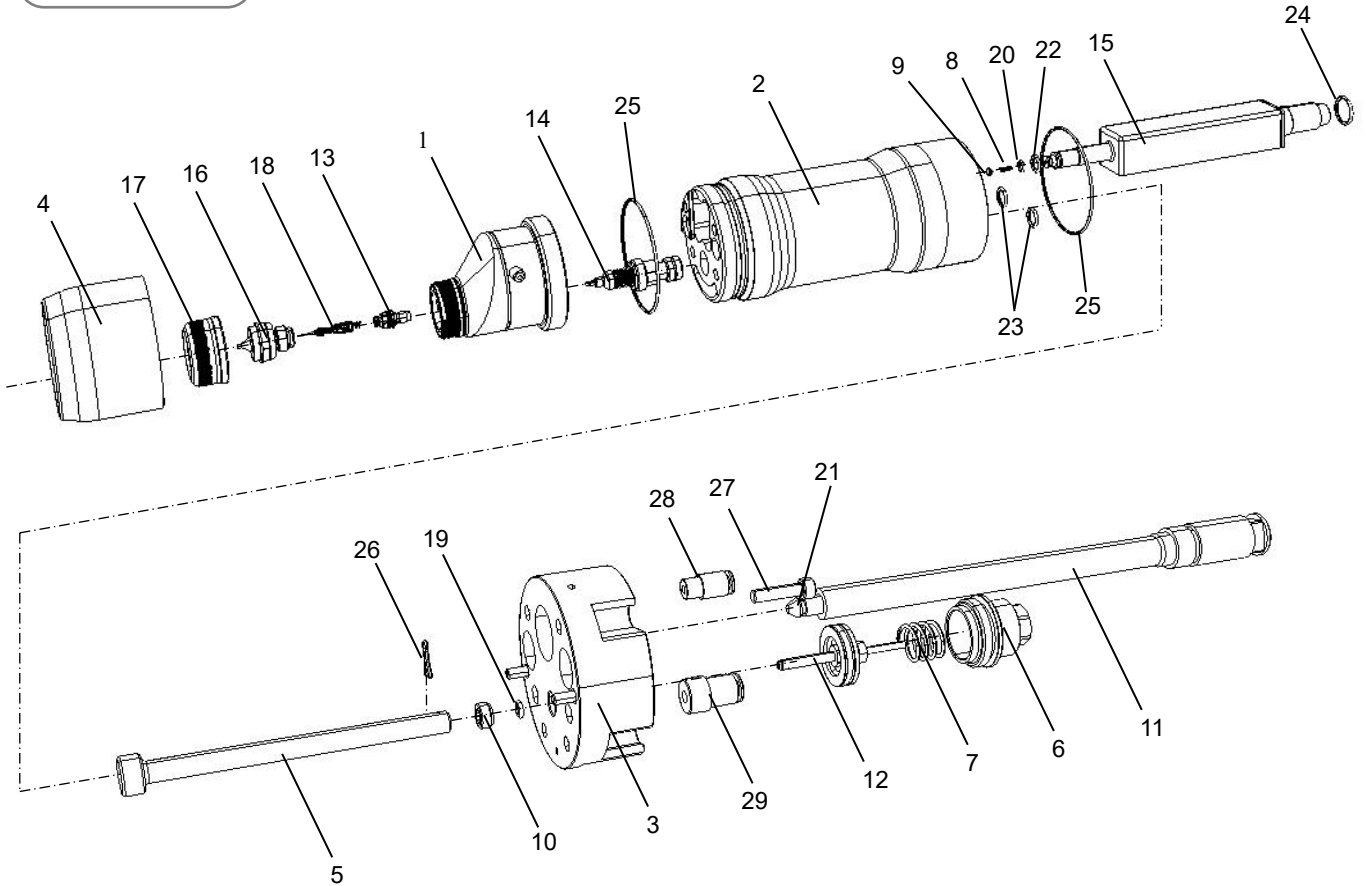

No.	Part No.	Product name	Qty	Remarks
1	1724	Front block	1	
2	1833-002	Rear block	1	
3	1833-003	Back plate	1	
4	1833-004	Shroud	1	
5	1833-005	Rear shaft	1	
6	1833-006	Cap	1	
7	1833-007	Spring	1	
8	1833-008	Spring	1	
9	1833-009	Contact	1	
10	1833-010	Cap nut	1	
11	1833-011	Plug	1	
12	1725	Piston ASSY	1	
13	1726	Paint seat	1	
14	1727	Bellows seal ASSY	1	
15	131E-214	Cascade	1	
16	15F7	Paint nozzle ASSY	1	

No.	Part No.	Product name	Qty	Remarks
17	1707	Retaining nut ASSY	1	
18	1718	Charge electrode	1	
19	101-9005	O-ring	1	
20	101-9006	O-ring	1	
21	101-9007	O-ring	1	
22	101-9010A	O-ring	1	
23	101-9012	O-ring	2	
24	130-9020	O-ring	1	
25	130-9085	O-ring	2	
26	49-10220	Split pin	1	
27	03-70625	Hex. socket head cap screw	4	
28	378-0601	Straight with hex. socket (φ6)	1	
29	378-0803	Straight with hex. socket (φ8)	2	
30	1719	Set of accessory parts	1	
31	35EE-1	Accessory tool	1	

## 11.2 Replacement Parts

The replaceable parts in the part ASSY are shown below.

Regarding the parts that are not shown below, replace the ASSY.

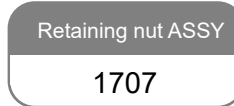
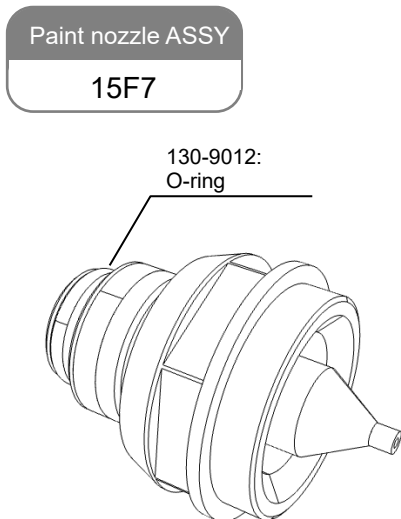
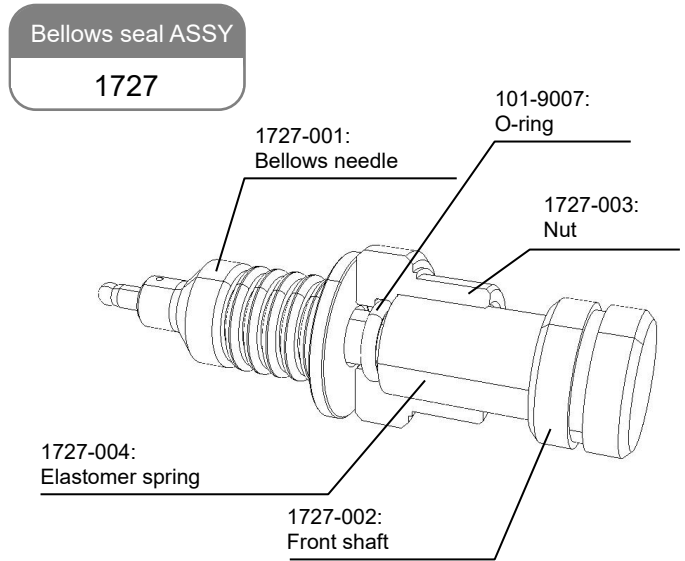
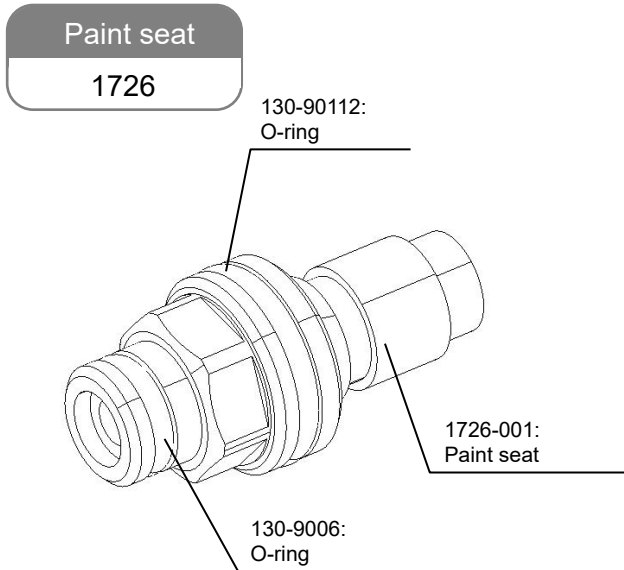
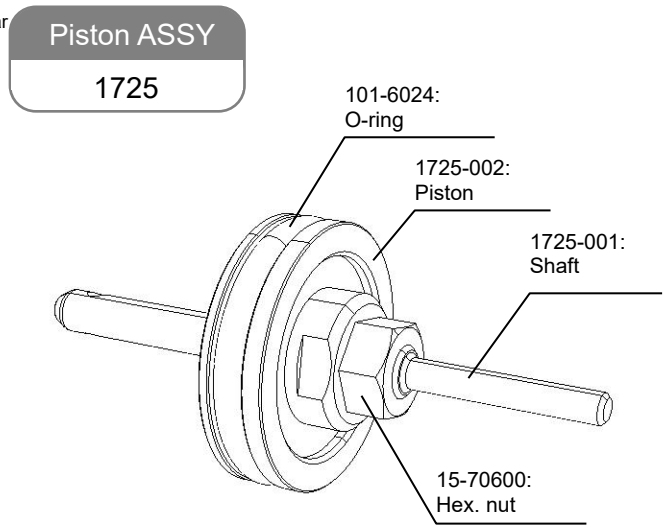
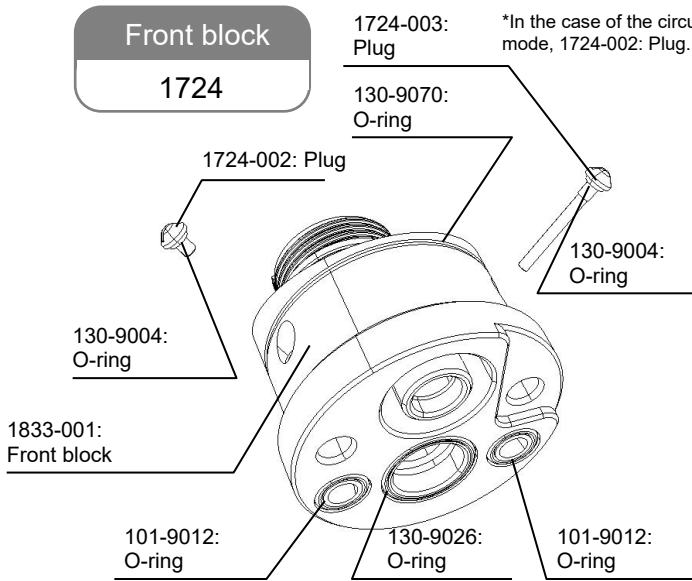

\*When you remove the ring seal, it is highly likely that it is damaged. Therefore, be sure to replace the ring seal.

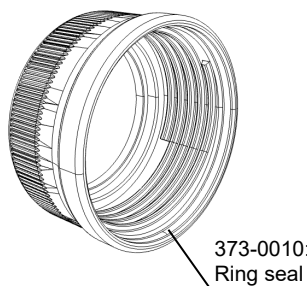

Set of accessory

1719

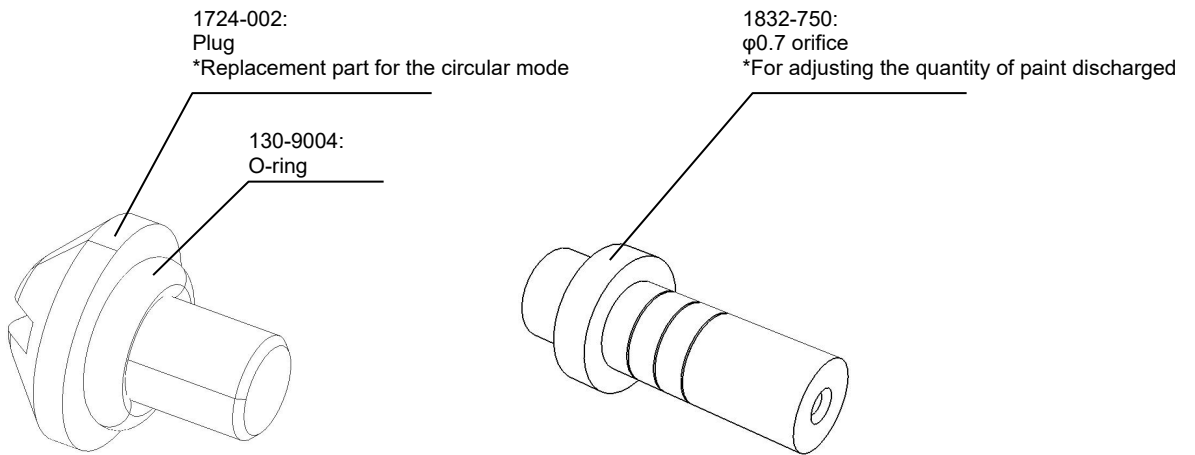

Accessory tool

35EE-1

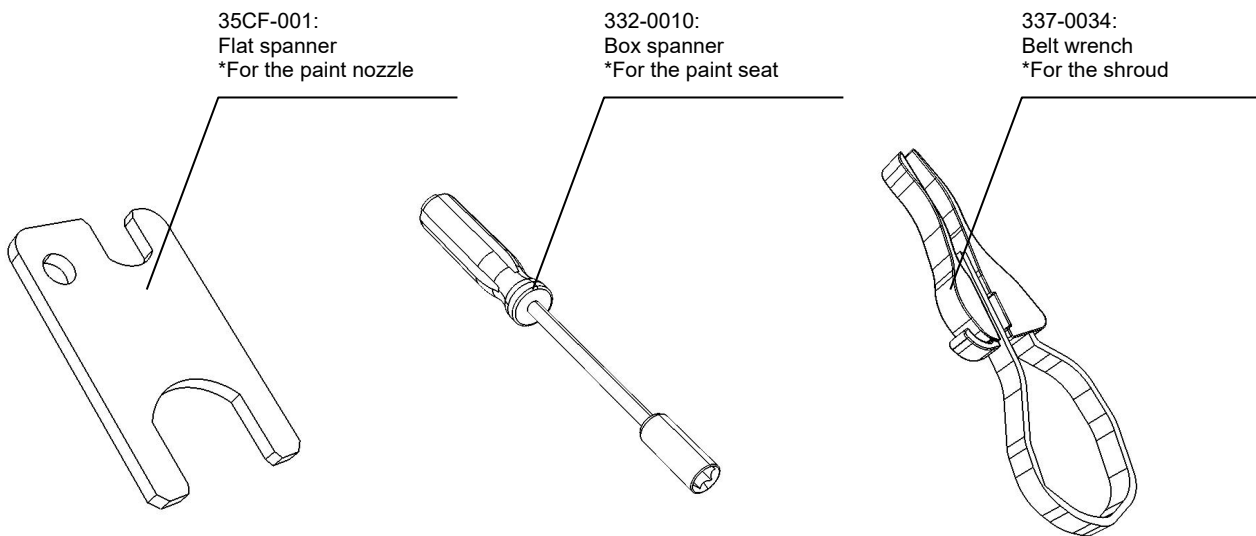



ASAHI SUNAC CORPORATION (the “Company”) shall provide the original purchaser (the “Purchaser”) with warranty service for a period of one (1) year from the date of purchase of the product, as follows:

- Should you find defects in design or workmanship with regard to parts, ship them back to the Company, with freight prepaid. The Company shall repair or replace the parts free of charge and reimburse the freight charges, provided that, as a result of an inspection and investigation of the parts conducted by the Company, the defects are deemed to be attributable to the factors within the Company’s responsibility.
- In the following cases, free after-sales service is not provided.
  1. Failure resulting from an inappropriate method of installing this equipment.
  2. Failure resulting from a use method not conforming to this instruction manual or mishandling.
  3. Failure resulting from insufficient maintenance management of this equipment and incorrect handling such as non-conformance to the procedures specified in this instruction manual.
  4. Failure resulting from unauthorized alteration or structure change of this equipment without the Company’s consent.
  5. Failure due to force majeure such as earthquake, disaster, flood disaster or lightening.
  6. Warranty for consumables worn or deteriorated even in the case where this equipment is used correctly.
  7. Repair after the machine has been used outside Japan, and shipping cost.
  8. In addition to the above, failure due to circumstances beyond our control.
- As for items such as parts purchased by the Company from another manufacturer, the warranty of that manufacturer shall apply.
- As for any parts deemed to be defective, the Company shall not be held liable for any expenses beyond the provision of repair or replacement parts free of charge.
- The Company shall not be held liable for any damage to the Purchaser caused by factors not attributable to the Company, such as misuse of product, etc.

【MEMO】

【MEMO】



- 
- When a transfer of title of this equipment takes place, please see to it that this Operation and Maintenance Manual is handed over to the new owner.
  - This equipment is manufactured in compliance with the Laws and Regulations of Japan. Therefore, use of this equipment is limited to Japan only. In the rare eventuality of this equipment being used outside Japan, compliance with the safety standards of the relevant countries is of course mandatory.
- 

20th Edition: February 16, 2026

## ASAHI SUNAC CORPORATION

HEAD OFFICE  
5050, SHINDENBORA, ASAHIMAE-CHO,  
OWARIASAHI, AICHI PREF. 488-0852, JAPAN  
PHONE +81-561-52-0717 FAX +81-561-54-8847

URL : [www.sunac.co.jp](http://www.sunac.co.jp)  
E-mail : [ctrd01@sunac.co.jp](mailto:ctrd01@sunac.co.jp)

Sales office



English



Chinese

20th Edition: February 16, 2026