

Operation and Maintenance Manual

Dual Electric Field Type Automatic Powder Coating Gun

ECDa

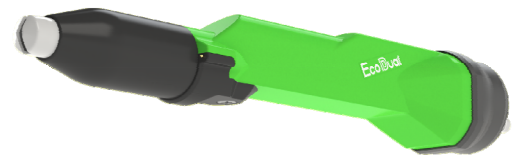

This manual contains important warnings and cautions. Be sure to read this manual carefully before using this machine. Always keep this instruction manual handy until the product is disposed of, if it is lost or soiled, request it from your dealer or us.

Introduction

Thank you for purchasing our product Dual Electric Field Type Automatic Powder Coating Gun <ECDa>.

Please be sure to read this operation manual carefully before using this product so that you can always use it under the optimum conditions.

In particular, please fully understand the items in the specifications and use them according to the correct usage.

This product is used in combination with an electrostatic controller (BPS900a).

Be sure to read the operation manual of the electrostatic controller carefully.

If you have any questions, please contact us by clearly stating the "product number" and "serial number" and contacting us on the back cover.



Please keep this operation manual in a safe place where you can easily refer to it.

Content	
1	For safe and correct use ······ 1
2	Equipment Overview ······ 7
	2.1 Names and Functions of Parts ······ 7
	2.2 Example of Coating Machine Installation ······ 8
	2.3 Accessories ······ 9
	2.3.1 Nozzle and Muzzle ······ 9
	2.3.2 Powder Hose ······ 12
	2.3.3 Cleaning Air Tube ······ 12
	2.3.4 Electrostatic Cable ······ 12
	2.3.5 Reciprocating Pipe ······ 12
	2.3.6 Mounting Brackets ······ 12
3	Specifications ······ 13
	3.1 Outer Shape ······ 13
	3.2 Product Specifications ······ 13
4	Preparing Equipment ······ 14
	4.1 Gun Cable Connection ······ 14
	4.2 Cleaning Air Tube Connection ······ 14
	4.3 Powder Hose Installation ······ 15
	4.4 Gun Installation to Reciprocating Pipe ······ 15
	4.5 Cover Installation ······ 16
	4.6 Nozzle Installation ······ 17
5	Paint Preparation and Paint Work ······ 19
	5.1 Paint Supply ······ 19
	5.2 Spray Distance ······ 19
	5.3 At Work Cancellation and at Work Completion ······ 19
	5.4 Gun Cable/Powder Hose Bundling and Safety Precautions ······ 20
6	Maintenance and Inspection ······ 21
	6.1 Nozzle Maintenance ······ 21
	6.2 Gun Maintenance ······ 22
	6.3 Consumable Parts ······ 22
7	Troubleshooting ······ 23
8	Replacing Parts ······ 26
	8.1 Nozzle Replacement ······ 26
	8.2 Joint Plate ASSY Replacement ······ 26
	8.3 Lower Pipe ASSY Replacement ······ 27
	8.4 DE Pad Replacement ······ 28
9	Component ······ 29
	9.1 ECDA ······ 29
	9.2 Component Assemblies ······ 30
10	Maintenance Log ······ 31
11	Warranty ······ 32

Please understand the contents of this instruction manual and be sure to follow the handling method. If you use it without following this instruction manual, **you may injure your body or damage your equipment and fire.**

The following safety precautions should be considered as minimum basic safety measures when using our products.

● **Precautions are displayed in the following two stages.**



WARNING

Hazards that can result in death or serious injury.



CAUTION

Danger that may result in minor or moderate injury or physical damage only.

● **Other important points are indicated as follows:**

NOTE

Observations to ensure the equipment's performance and functions are fully operational.

In addition, please observe all national and local laws and regulations related to fire, electricity, and safety, as well as the rules and regulations of your own company or business division.

« **Range of use suitable for the product** »

This product is an automatic spray gun designed to be installed in the coating booth equipped with an exhaust system and to spray for the powder paint.

If you use the product under conditions other than the above, it will be used improperly. Also, please be careful as it may cause an accident.

 **WARNING**

Fire and explosion



Preventing fire and explosion in coating shop

- **Do not use halogenated hydrocarbon solvents.**
The aluminum alloy contained in this product's components may undergo a chemical reaction and explode.
- **Do not use this product outside its specifications.**
Using it out of specification range may result in a fire hazard.
- **Provide adequate ventilation with ventilation equipment.**
Volatilized organic solvents and other substances may remain and ignite, creating a risk of fire.
- **Clean the coating room and exhaust system (ducts and fans) regularly.**
If the accumulated powder simply peels off, a spark may occur, which could cause a dust explosion.
In the unlikely event of a fire, paint residue etc. will make it easier for the fire to spread and result in greater damage.



Prevent fire and electric shock caused by faulty earthing

- **All conductive objects in the coating booth (paint containers, peripheral equipment, etc.) must be grounded with an earth wire.**
In an atmosphere ionized by high voltage, poorly grounded conductors can become charged, creating a risk of fire or electric shock due to spark discharge.
The earth should be **Class D grounding or higher** (ground resistance 100 Ω or less).
- **Always keep the workpiece earthed.**
Risk of fire or electric shock due to spark discharge from charged workpieces.
- **The injector and paint hose must be grounded with an earth wire.**
Static electricity can cause spark discharge, which can result in fire or electric shock.
When paint flows through the injector and paint hose, static electricity is generated and becomes charged.
- **The paint container must be grounded with an earth wire.**
The paint path can cause the paint container to become charged, a risk of fire or electric shock.
- **The electrostatic controller must be grounded with an earth wire.**
Static electricity can cause spark discharge, which can result in fire or electric shock.
Connect the earth wire with screws or other fasteners to prevent it from coming loose.

 **WARNING**

Fire and explosion



Prevent fire and electric shock caused by faulty earthing

- **Be sure to periodically remove any paint that has stuck to the hanger.**
If paint adheres to the contact part between the hanger and the object, there is a risk of fire or electric shock due to poor earthing.
The ground resistance value should be 1kΩ or less for metal (1MΩ or less for resin) (measurement voltage should be 500V or more).
- **Do not place any items in the coating booth that are not necessary for coating.**
Static electricity can cause spark discharge, which can result in fire or electric shock.
- **Paint operator must take precautions to prevent static electricity.**
Static electricity builds up on the human body, causing sparks to discharge, which may result in fire or electric shock.



Prevent fires caused by ignition of paints and solvents

- **When nozzle cleaning, turn off the power to the electrostatic controller.**
If high voltage is applied during nozzle cleaning, there is a risk of fire.
- **Do not bring any spark-producing devices, matches, lighters, etc.**
Risk of explosion or fire due to ignition of flammable materials.

Equipment misuse



Preventing accidents caused by poor maintenance

- **Any abnormal noise, vibration or high voltage leakage, immediately stop operation.**
Product damage may result in a fire hazard.
- **Do not operate if any parts are damaged or missing.**
Product damage may result in a fire hazard.

 **WARNING**

Human protection



Protection from high voltage

- **Please wear anti-static shoes.**
Static electricity builds up on the human body, causing sparks to discharge which may result in fire or electric shock.
- **Do not approach and touch the gun body while high voltage is applied.**
Touch with high voltage parts may result in electric shock.
- **The coating work floor must have an anti-static construction with a leakage resistance of 1 MΩ or less.**
There is a risk of electric shock to the operator.
The scope of the antistatic structure is the entire work floor in a closed paint room.
In an open paint booth, it is the area surrounded by 1.5m on either side of the booth opening and 2.5m in front of it.
To maintain the antistatic effect, clean the work floor when it becomes dirty.
- **Do not use this product if you have a pacemaker.**
The high voltage of this product may cause pacemakers to malfunction or stop functioning.



Protection from solvents, air and paint pressure

- **Do not spray paint towards person**
Harmful substances may cause serious injury, including inflammation and poisoning.
Pressurized paint can cause personal injury.
- **Wear protective glasses, a protective mask, and protective gloves*¹ when handling paint.**
Harmful substances may cause serious injury, such as inflammation or poisoning.
Carefully read the safety data sheet (SDS*²) of the paint you are using and take appropriate exposure prevention and protective measures.
*¹ When using protective gloves for skin absorption protection or to prevent dirt, it is necessary to prevent static electricity from building up on the human body.
Be sure to ground it properly. (Recommended protective gloves are those specified in JIS T8118, or earth bands, etc.)
*² SDS : Safety Data Sheet
- **Clean the coating room and exhaust device (ducts and fans) regularly.**
If the exhaust device does not function properly, harmful substances may cause serious injury, including inflammation and poisoning.

《Warning and precautions for safe use》

 **WARNING**

- **Do not use this product outside its specifications.**
Using it out of specification range may result damage to the product.
- **Do not immerse the coating machine, connection/extension cable or hoses in cleaning solvent.**
Electrostatic sprayer are electrical machines, immersing them in cleaning solvents may cause break down.
- **Connection/extension cable and hose should be hung from the ceiling or side walls and not dragged across the floor.**
It may cause damage such as scratches.
When using conductive paint, be sure to suspend the paint hose from an insulating material such as a rubber tube.
- **When cleaning the nozzle, never use a metal brush, use a bamboo brush or similar.**
It may damage the nozzle and result in poor coating.
The nozzle is an important part of the sprayer.
If you use a metal brush to damage the nozzle, it will become difficult to maintain uniform spray conditions.
- **Always keep a distance of at least 150mm between the tip of the nozzle and the work piece.**
The potential at the tip of the nozzle will decrease, causing poor coating results.
- **Check frequently for paint leaks, air leaks, and loose screw.**
- **Do not touch the electrode pins of the spray gun carelessly.**
The electrode pin may pierce the body and cause injury.
Be careful when handling the electrode pin as they are easily pierced.

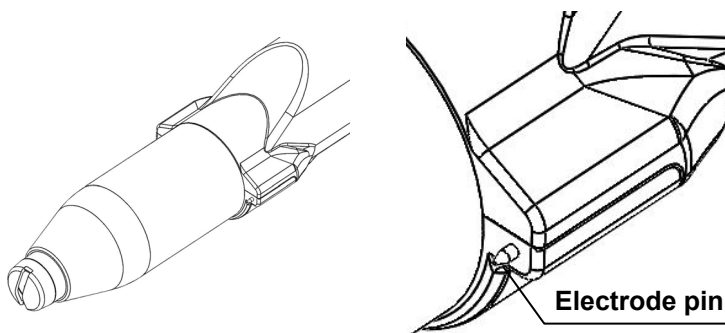

《Warning and precautions for safe use》

 **WARNING**

• **Do not install it like following.**

Electrostatic guns apply high voltage to the tip of the gun and the rear is earthed, make sure there are no obstacles on the main body (insulated part).

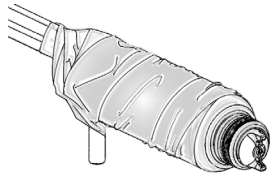

① If the gun is used with the dirt-proof sheet wrapped around it, moisture will accumulate inside, causing an overcurrent error.

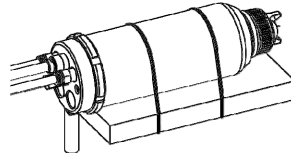

② If a metal plate is attached close to the gun body, insulation breakdown may occur between the charged part of the gun and the plate.

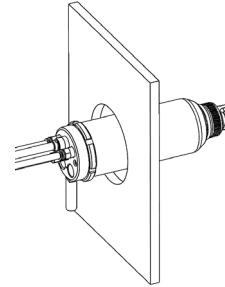

③ If the gun body is inserted through a hole in a metal plate, insulation breakdown may occur, just as in ②.

● **A fire extinguisher should always be kept near the work area.**

In case of a fire, make sure to have equipment that has been regularly inspected installed at all times.

● **When disposing of this product, please dispose of it in accordance with the laws of your country.**

2

Equipment Overview

2.1 Names and Functions of Parts

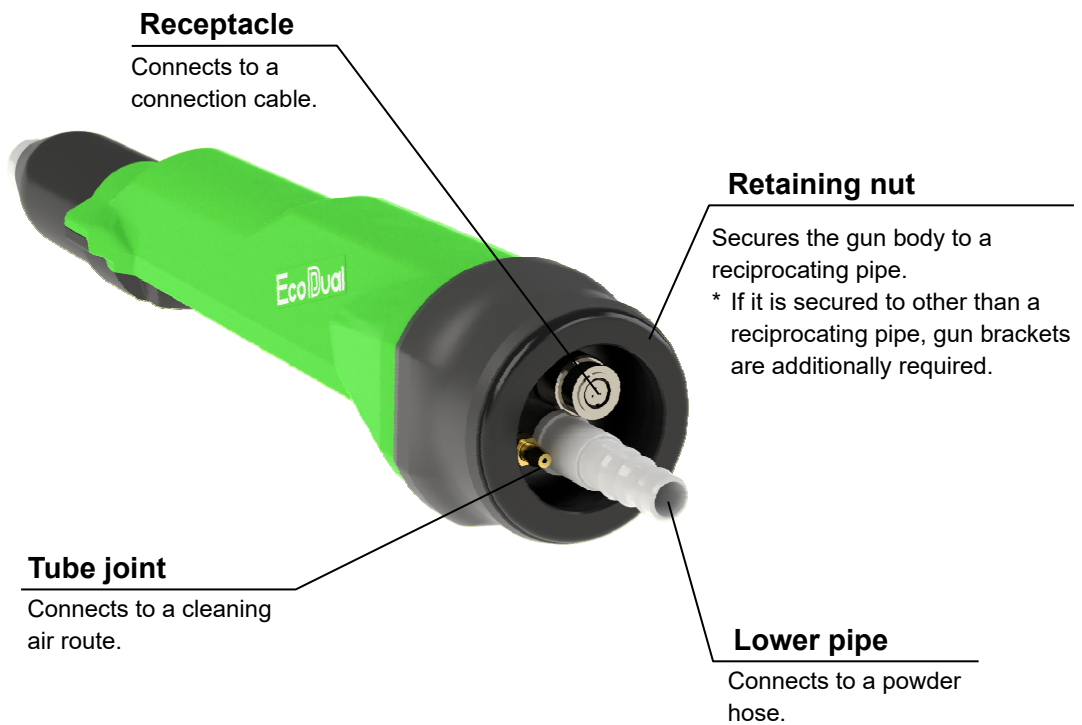
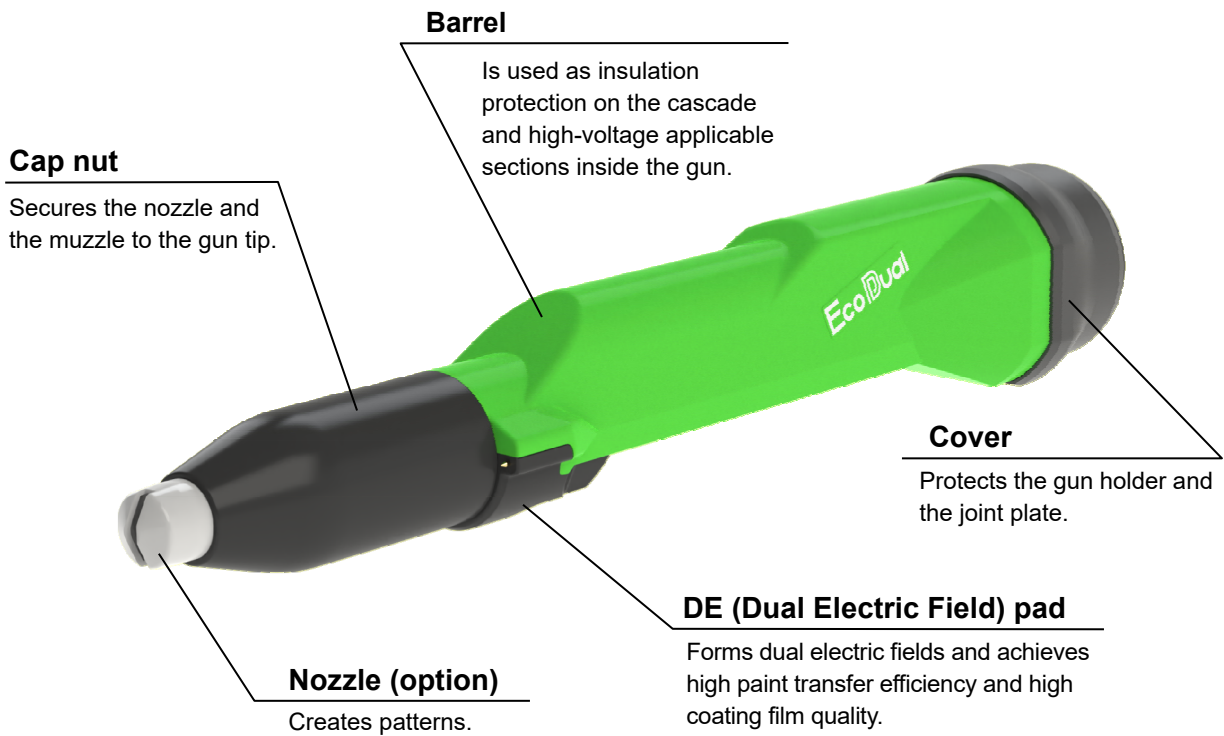

2.2 Example of Coating Machine Installation - With reciprocating pipe -

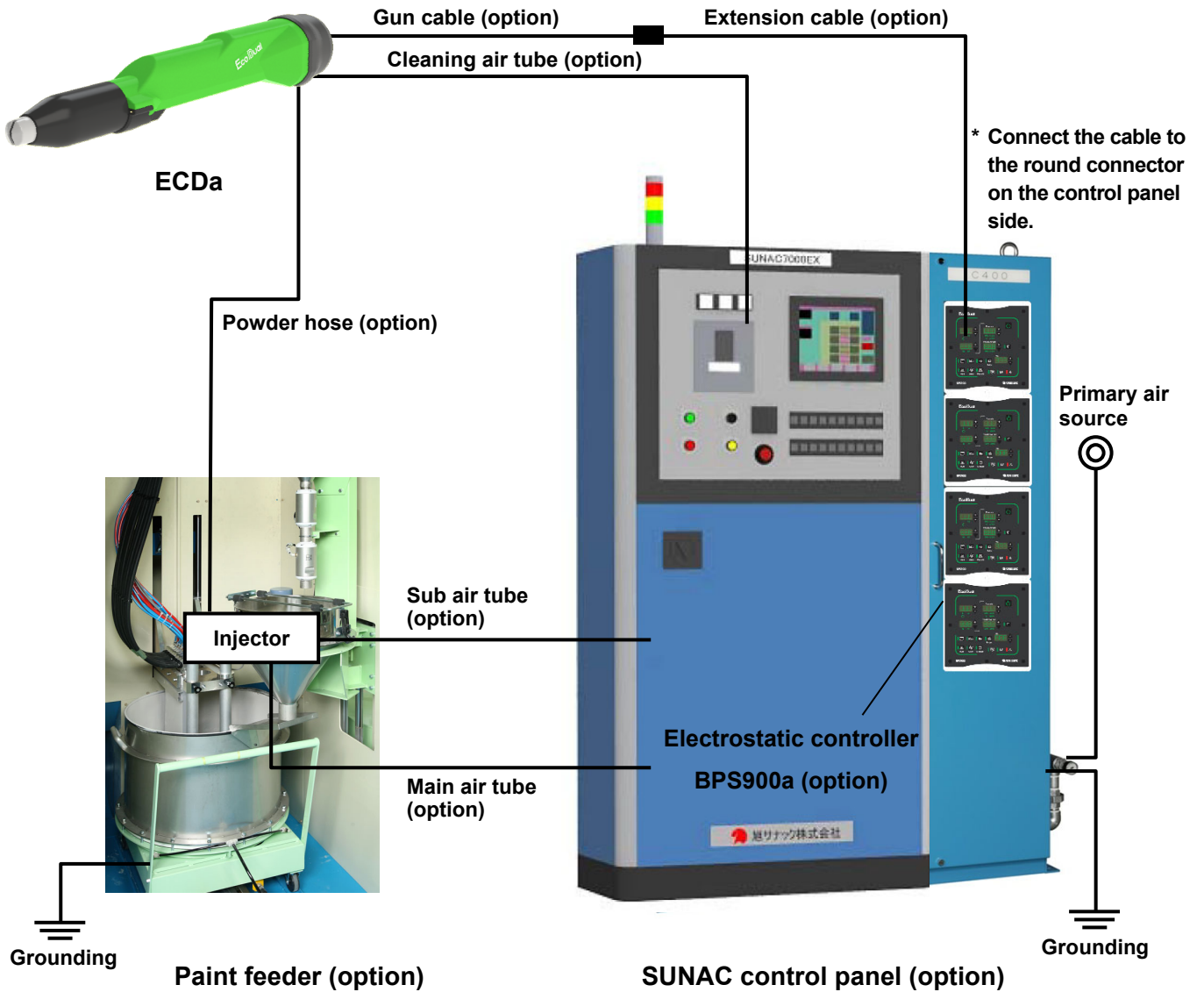

NOTE

Install the electrostatic controller (unit) outside the paint booth while keeping it away from the booth opening or the entrance/exit for 1.5 m or more.

⚠ WARNING

The coating machine does not include the nozzle. It is an optional part. Please additionally obtain the nozzle of a specification to your purpose.

2.3 Accessories

- The accessories are required for operation and use of the equipment.
Select the accessories suitable for your purpose and working conditions from the following and **obtain additionally.**

2.3.1 Nozzle and Muzzle (Model: PFX/PRX series): option

- These parts are intended to be mounted at the tip of the coating machine and help form spray patterns with forces of air.
- Select the air cap of a specification applicable to your purpose according to the table below.

! WARNING

Be sure to use the ECDa specific nozzle.
This may result in damage to equipment or unexpected accidents.

Image of nozzle and muzzle

Flat nozzle

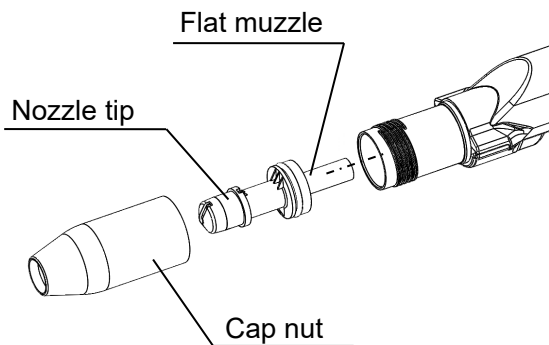

Round nozzle

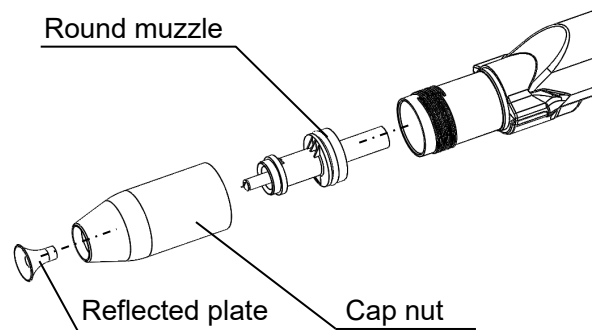

Nozzle selection reference

Flat nozzle (PFX)

Part Number	Part name	Effective pattern width
15E3-1	Flat nozzle SN	Approx. 130 mm
15E2-1	Flat nozzle N	Approx. 170 mm
15E4-1	Flat nozzle W	Approx. 200 mm
15E1-1	Flat nozzle SW	Approx. 230 mm
15E5-1	Flat nozzle SSW	Approx. 250 mm
15E6	Pattern cap	Approx. 130 mm, 170 mm, 200 mm (for flat nozzle W only)

*For paint distance of 200 mm

Round nozzle (PRX)

Part Number	Part name	Effective pattern width	Usage example
15E7-1	Round nozzle	-	Pipe inner surface, etc.

Image of pattern cap

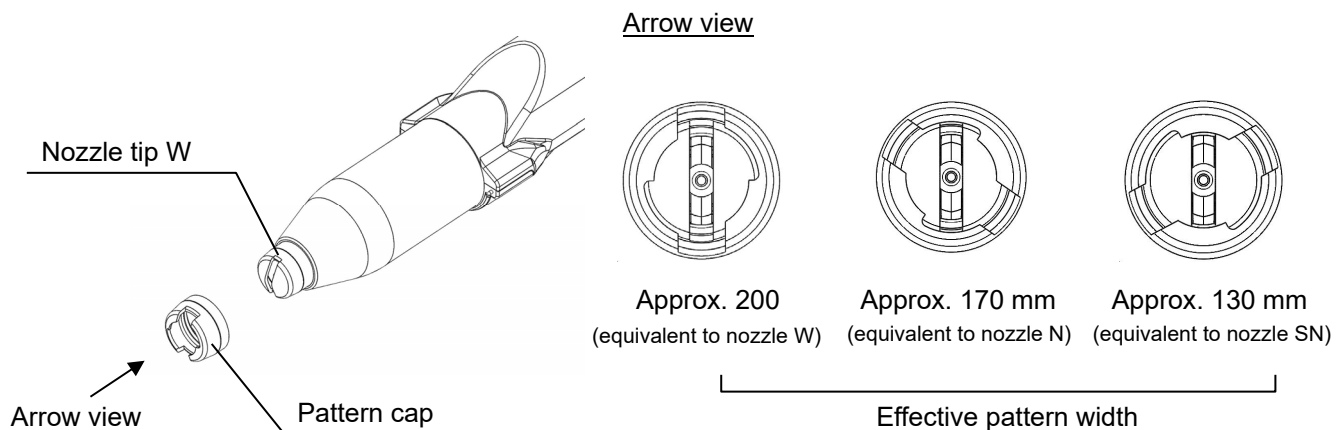

* The O-ring (130-6022) configured in the pattern cap is a consumable. If wear or damage is observed during cleaning or inspection, please replace it.

List of nozzle and muzzle part Nos.

Flat nozzle

15E1-1 , 15E2-1 , 15E3-1 , 15E4-1 , 15E5-1 , 15E6
 Nozzle SW , Nozzle N , Nozzle SN , Nozzle W , Nozzle SSW , Pattern Cap

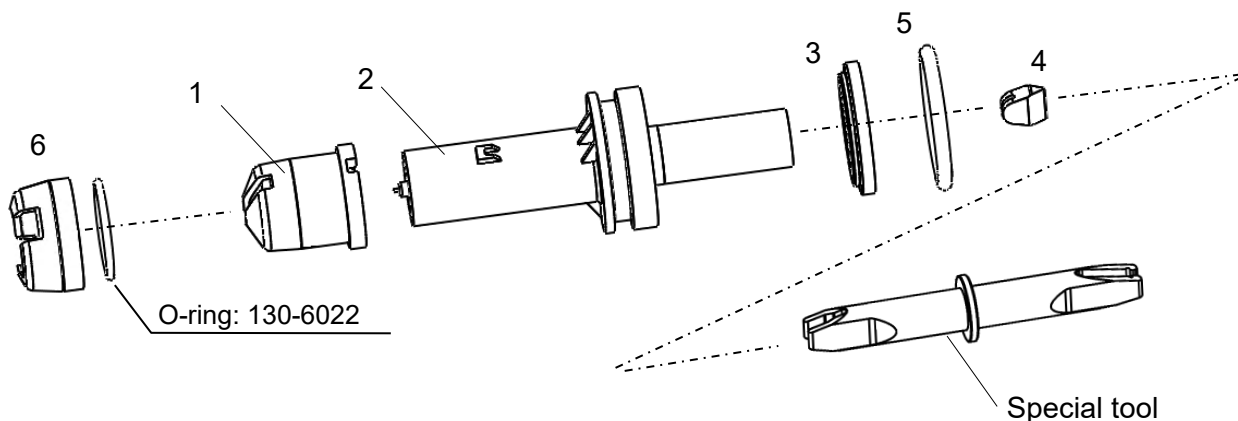

No.	Part Number	Part name	Q'ty	Remarks
1	15E3-001	Nozzle tip SN	1	Effective pattern width, approx. 130 mm
	15E2-001	Nozzle tip N	1	Effective pattern width, approx. 170 mm
	15E4-001	Nozzle tip W	1	Effective pattern width, approx. 200 mm
	15E1-003	Nozzle tip SW	1	Effective pattern width, approx. 230 mm
	15E5-001	Nozzle tip SSW	1	Effective pattern width, approx. 250 mm
2	15E1-101	Flat muzzle ASSY	1 set	A contact ring is also attached.
3	15E1-001-4	Contact ring	1	When the contact ring only is replaced
4	15E1-102	Holder rear end	1	
5	102-9025	O-ring	1	
6	15E6	Pattern cap	1 set	Only for nozzle W (option)
Tool	8906-102	Swap tool	1	For attaching and detaching the holder rear end

NOTE

- When selecting the most suitable nozzle for each work, please conduct a coating test before making your decision.
- The rear end of the holder may wear out in a short period of time depending on the paint. In that case, please use wear-resistant **15E1-004 (sold separately)**. However, wear-resistant specifications may cause paint welding or clogging, so be careful when using them.

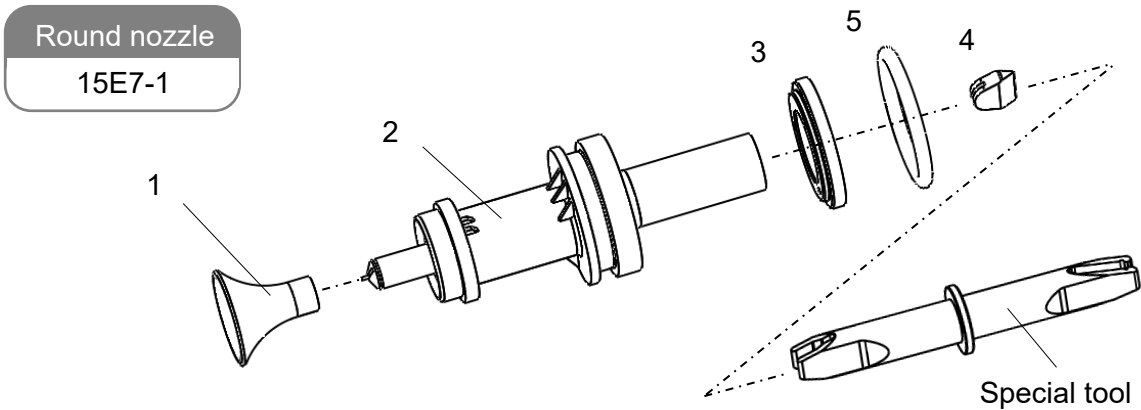

No.	Part Number	Part name	Q'ty	Remarks
1	15FF-003	Reflected plate $\Phi 16$	1	
	15FF-004	Reflected plate $\Phi 24$	1	
	15FF-005	Reflected plate $\Phi 32$	1	
2	15E7-101	Round muzzle ASSY	1 set	A contact ring is also attached.
3	15E1-001-4	Contact ring	1	When the contact ring only is replaced
4	15E1-102	Holder rear end	1	
5	102-9025	O-ring	1	
Tool	8906-102	Swap tool	1	For attaching and detaching the holder rear end

NOTE

- The rear end of the holder may wear out in a short period of time depending on the paint. In that case, please use wear-resistant **15E1-004 (sold separately)**. However, wear-resistant specifications may cause paint welding or clogging, so be careful when using them.

How to attach and detach

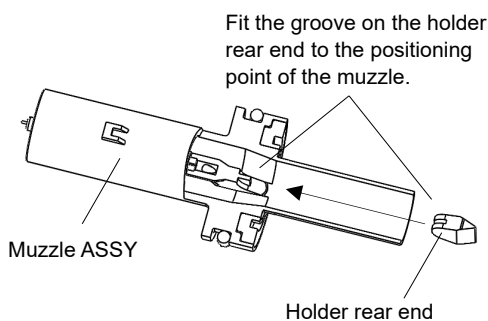

<Attachment of holder rear end>

Insert it using the no claw side of the swap tool.

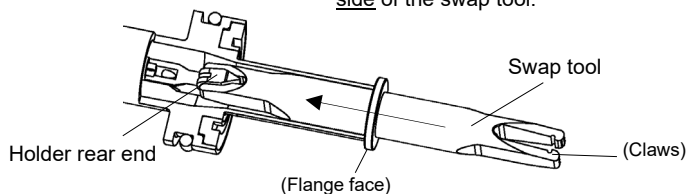

<Detachment of holder rear end>

Insert the claw side of the swap tool up to the flange face and pull out the tool with the holder rear end hooked.

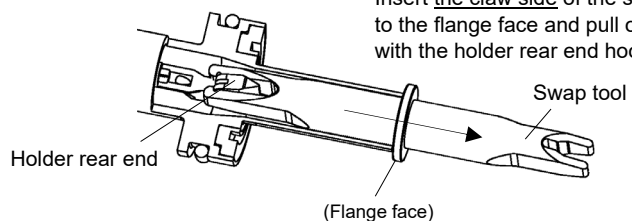

2.3.2 Powder Hose (option)

- The powder hose sends paint from the feeder to the paint machine. It uses a high-flexibility tube and is easier to handle.

Part Number	Part name	Specifications	Remarks
628-0000	SC black hose	Φ12.5 × 17.5	
640-0000	Powder hose	Φ11 × 16	Use the injector (AJ1) because it cannot be grounded.
641-0000	Powder hose	Φ12 × 18	

* Ask our staff for the length that you need.

* Minimum unit: 1 m

2.3.3 Cleaning Air Tube: option

- It sends air to the electrode and prevents paint from building up.

Part Number	Part name	Specifications
586-0000	Urethane tube	Φ4 × 6

* Ask our staff for the length that you need.

* Minimum unit: 1 m

2.3.4 Electrostatic Cable: option

- It supplies electric power to the coating machine body and extends the cable. (Up to 30 m)

Part Number	Part name	Specifications
2579	Gun cable	2 m (for reciprocating pipe)
2552	Connection cable	10 m
2575	Connection cable	20 m
2549	Extension cable	10 m
2549-1	Extension cable	20 m

2.3.5 Reciprocating Pipe: option

- Fixing pipe when connecting to reciprocating machine

Part Number	Part name	Specifications
8308-090	Reciprocating pipe	1 m

Example of connection

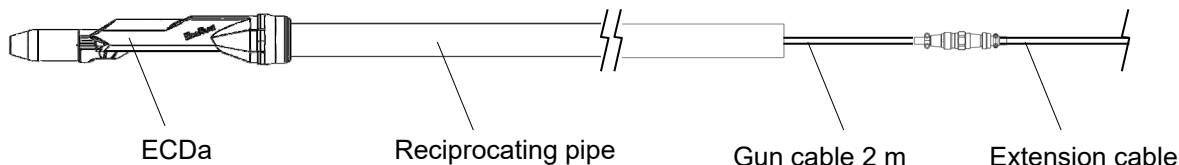

2.3.6 Mounting Brackets: option

- Fixing bracket when connecting with robot and fixing type

Part Number	Part name	Specifications
8907	Gun Bracket ASSY	

Example of connection

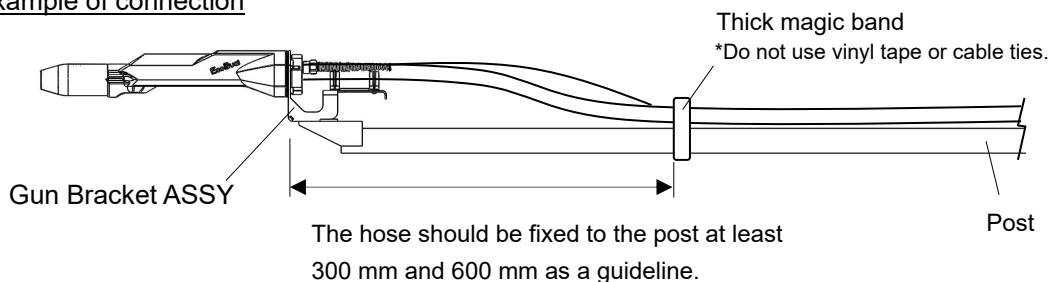

3

Specifications

3.1 Outer Shape

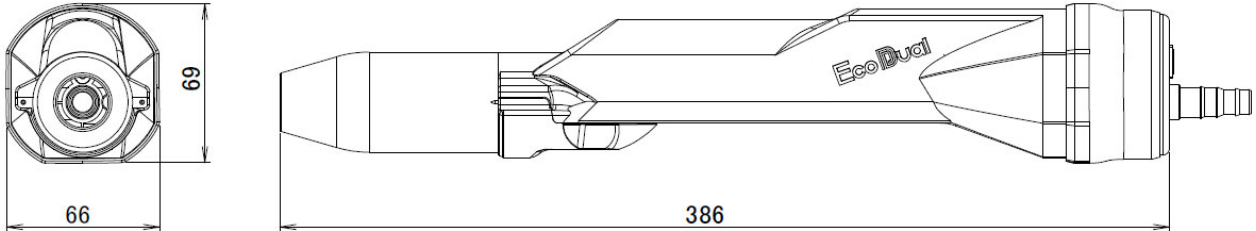

3.2 Product Specifications

Series name	EcoDual			
Name	Dual Electric Field Type Automatic Powder Coating Gun			
Model	ECDa			
Applicable paint	Powder paint			
Paint spray amount	Standard usage range: 50 to 350 g/min *It varies according to the injector, paint, or hose used for the work.			
Max. applied voltage	DC-80 kV			
Max. electric current	80 μ A			
Service environment	Temperature: 5 to 40°C Humidity: 40 to 80%			
Weight	517 g (except for nozzle, muzzle, and gun cable)			
Electrostatic controller	BPS900a			
Connection cable length	10 m (up to 30 m with extension cable)			
Supply air conditions	JIS B 8392-1:2012		Quality class 162	Quality class 131
	Number of contained solid particles (per 1 m ³) *Particle diameter: d	0.1 μ m < d \leq 0.5 μ m	20,000 or less	20,000 or less
		0.5 μ m < d \leq 1.0 μ m	400 or less	400 or less
		1.0 μ m < d \leq 5.0 μ m	10 or less	10 or less
	Water content		1.37 g/m ³ or less (Dew point at atmospheric pressure -17°C)	0.144 g/m ³ or less (Dew point at atmospheric pressure -42°C)
Oil content		0.1 mg/m ³ or less	0.01 mg/m ³ or less	
* Please arrange the quality class 162 or higher for compression air quality to supply to our coating machine (Quality class 131 recommended).				

4

Preparing Equipment

The following procedure shows how to prepare when you firstly use the equipment.

4.1 Gun Cable Connection

Connect the gun cable to the receptacle fixed to the joint plate.

* Cable tilt may cause poor connection. Please check that it is securely tightened to the end.

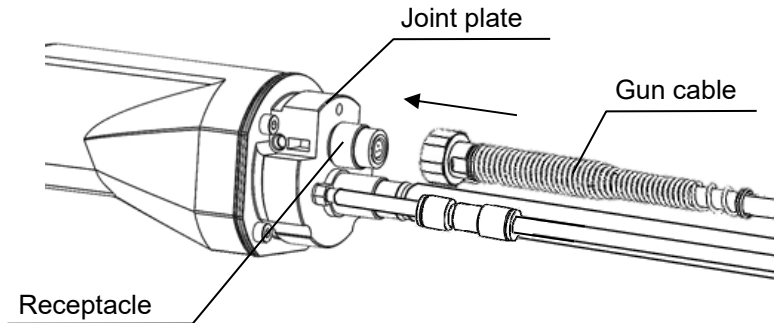

CAUTION

Risk of paint failure or equipment damage.

Wipe the connector with a clean cloth for any contamination.

4.2 Cleaning Air Tube Connection

Connect the cleaning air tube that supplies cleaning air to wash the nozzle to the quick joint connected to the joint plate. (Applicable tube inner diameter = $\Phi 4$ mm/outer diameter = $\Phi 6$ mm)

Be sure to supply air to maintain cleaning air function. (Recommended air flow rate: 6 to 8 L/min)

* Before using cleaning air, make sure that a porous plug is attached to the gun tip.

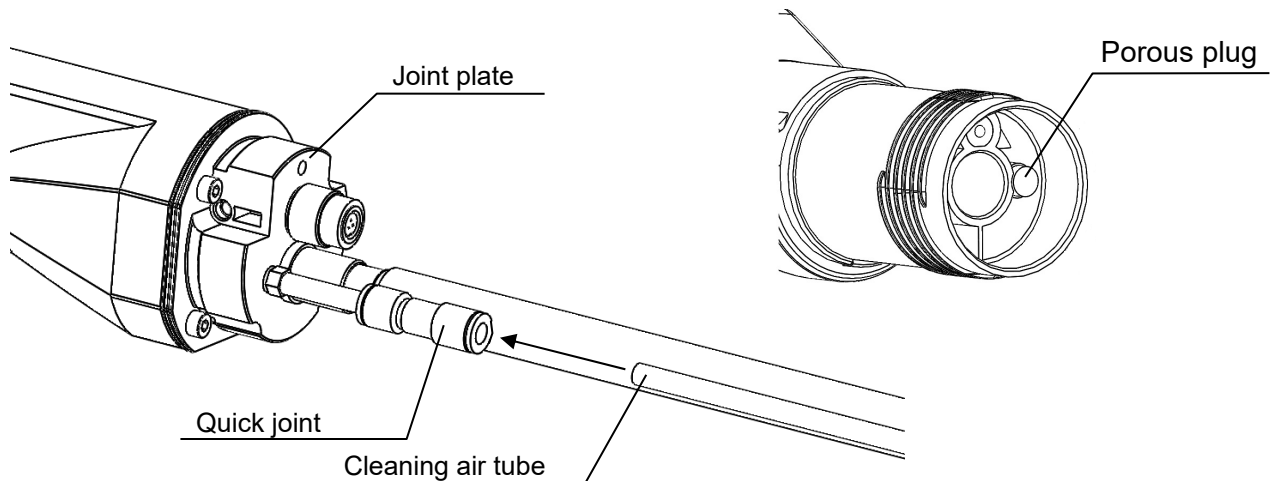

4.3 Powder Hose Installation

Connect the powder hose that sends paint to the lower pipe ASSY fixed to the joint plate. (Applicable hose inner diameter $\Phi 11$ or $\Phi 12$, SC black hose $\Phi 12.5$)

* Insert the powder hose to the recommended position, but do not force it in too deep. This may cause damage to parts.

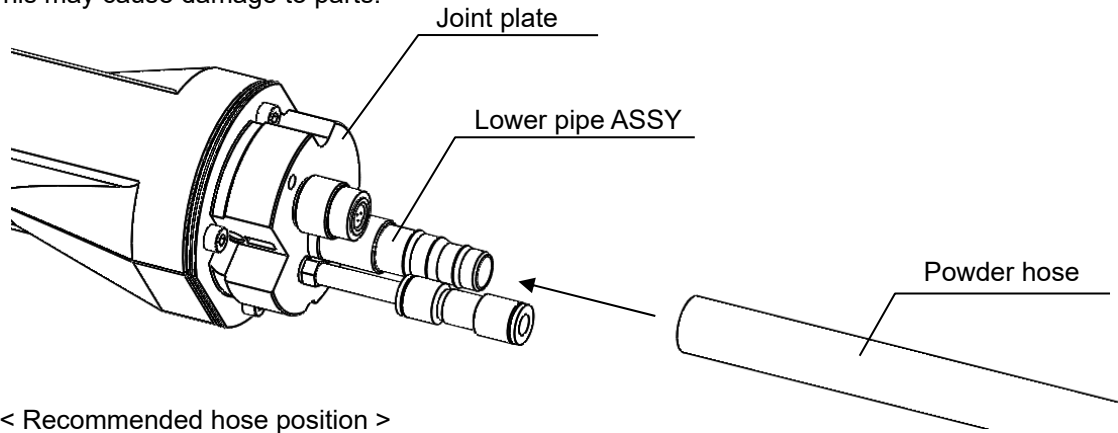

< Recommended hose position >

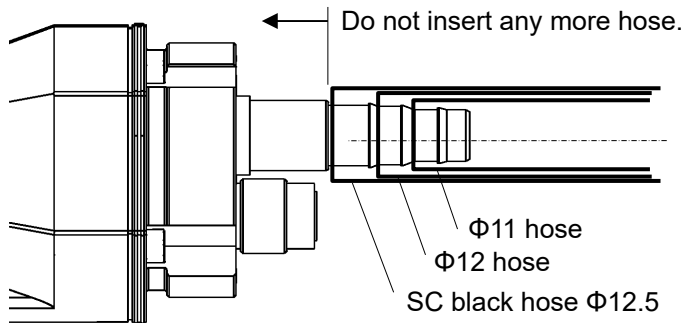

4.4 Gun Installation to Reciprocating Pipe

Put a retaining nut through the reciprocating pipe (option)

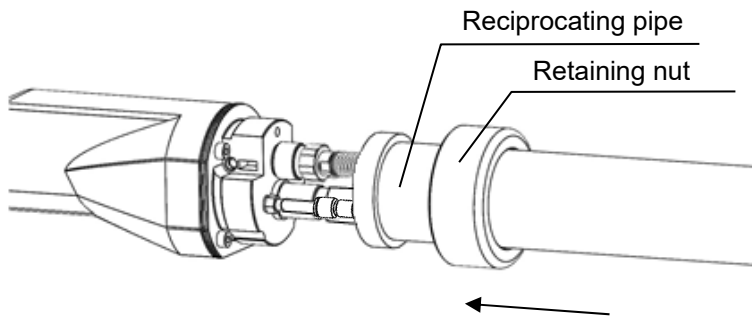

Fasten the retaining nut to the screw section of the joint plate to fix the gun.

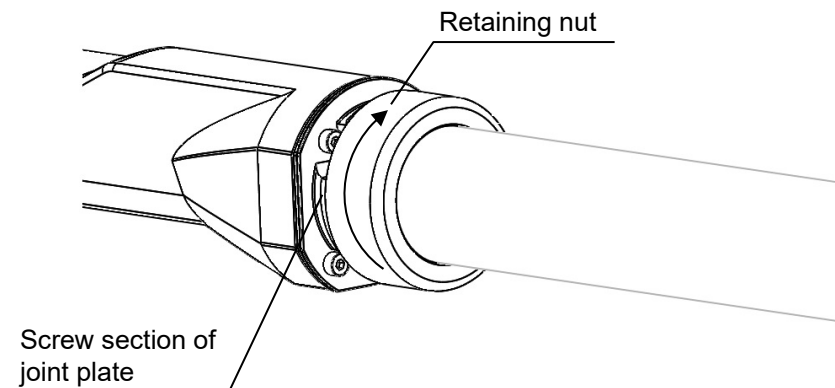

4.5 Cover Installation

Pass the cover through the reciprocating pipe.

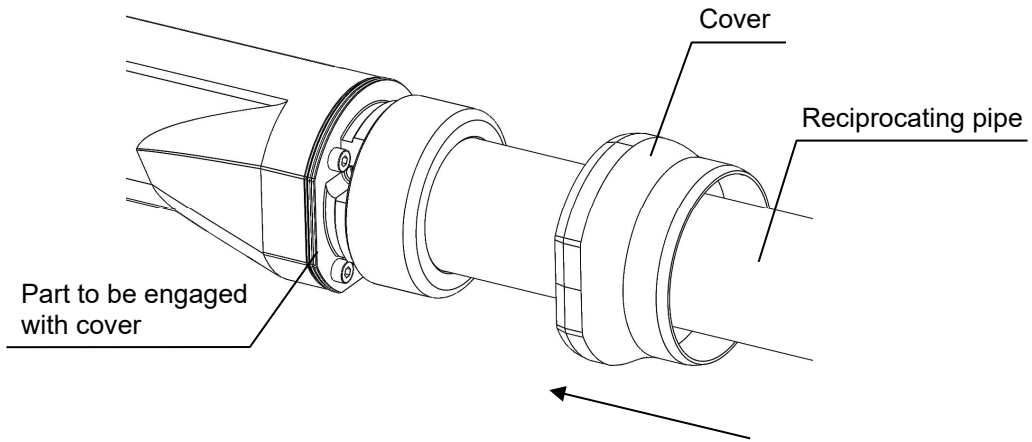

Mount the cover on the external side of the joint plate.

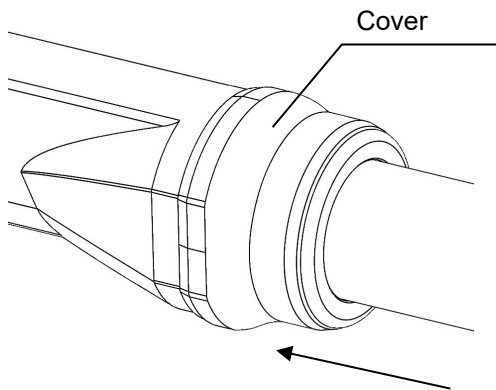

* The cover has the top side and the bottom side. Mount in the direction where the shapes match.

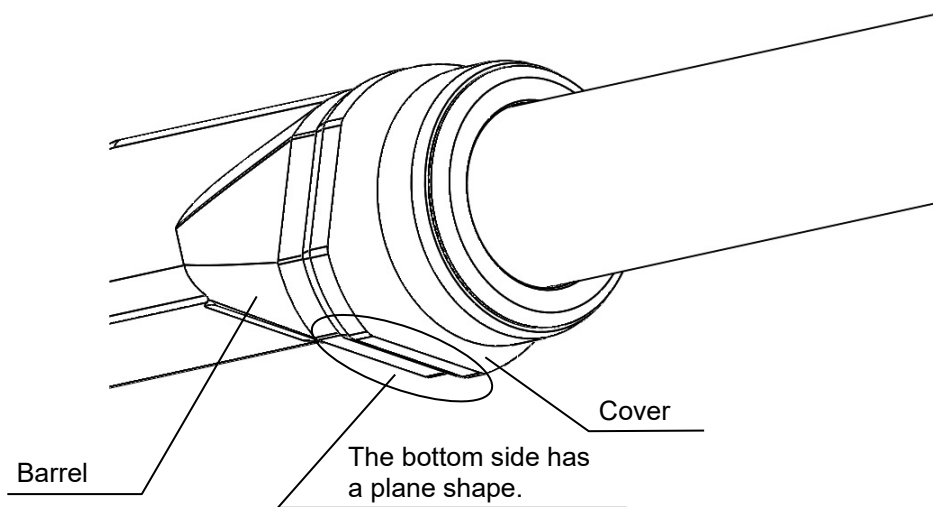

4.6 Nozzle Installation

- (1) Before mounting the nozzle, check that the contact ring of the muzzle and the holder rear end are suitably mounted.

**CAUTION**

Risk of paint failure or equipment damage.
When installing the muzzle on the automatic gun, check that it is correctly installed so that the groove of the contact ring comes to the front side.
(Refer to the figure below.)

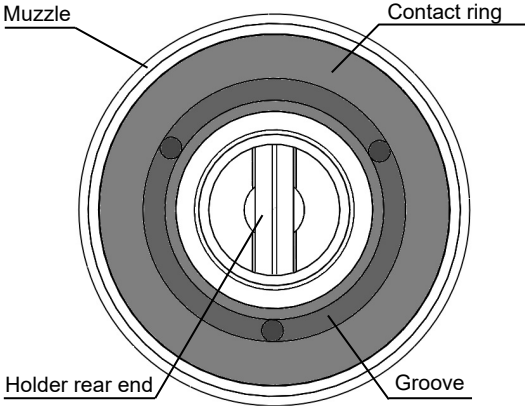

<Correct installation>

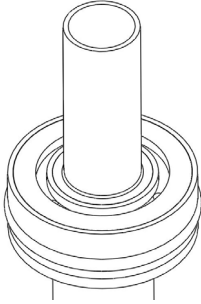

<Incorrect installation>

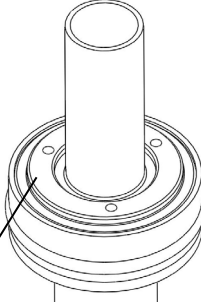

The contact ring is sticking out from the muzzle.

- (2) Check that there is no foreign object between the contact ring at the muzzle side and the gun contact section.

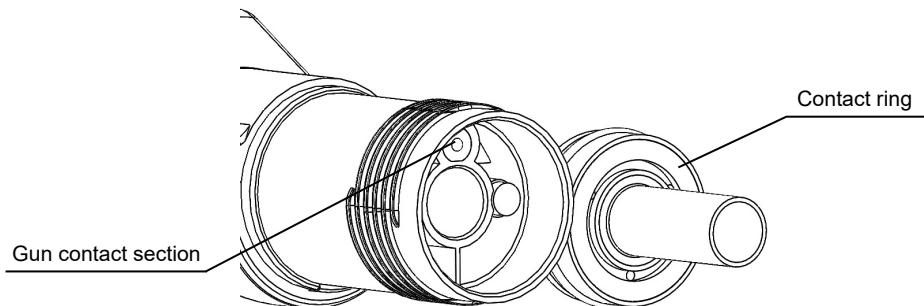

- (3) Insert the muzzle to the gun tip.

Flat nozzle

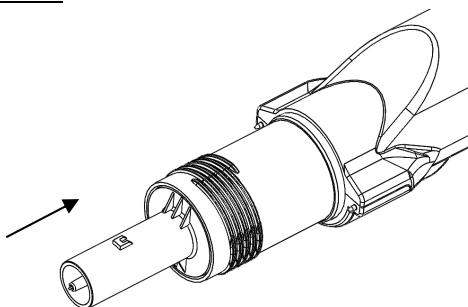

Round nozzle

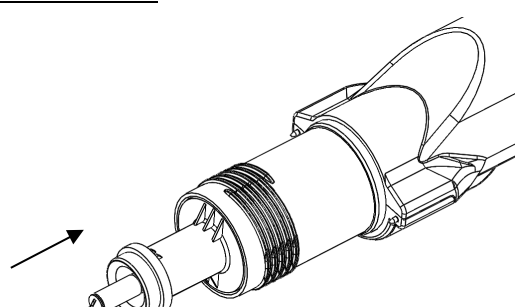

(4) Mount the nozzle tip if a flat nozzle is used.

* When installing, align the nozzle tip groove with the muzzle protrusion.

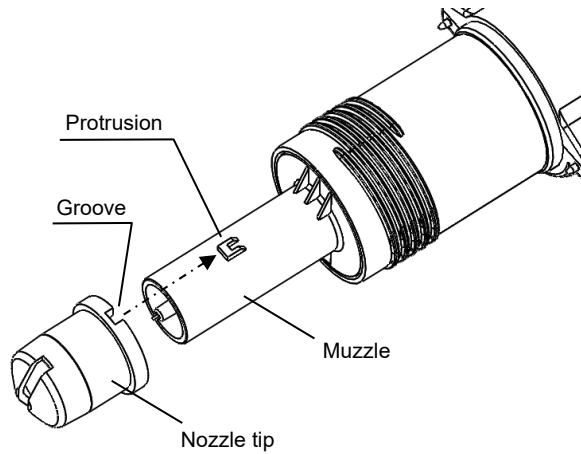

(5) Fasten the cap nut in to fix the nozzle tip.

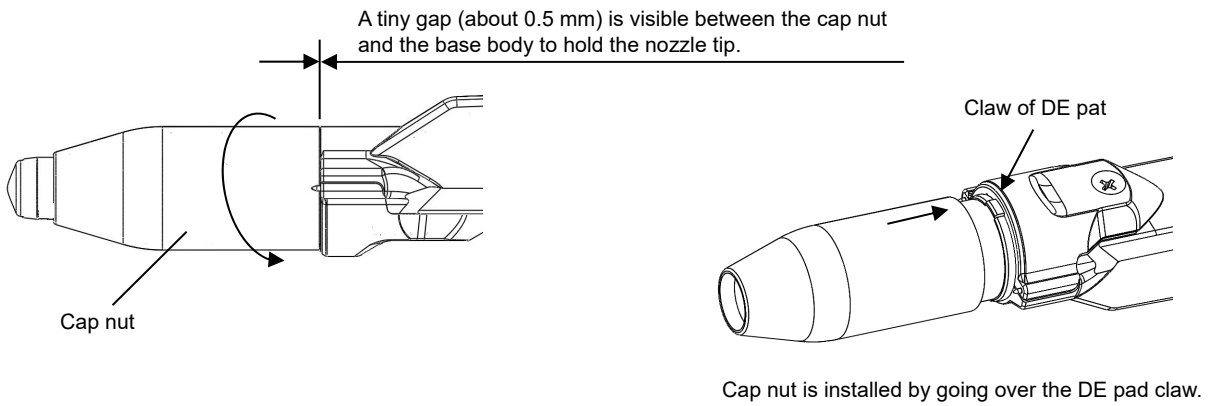

(6) Install a reflected plate to the electrode holder lastly if a round nozzle is used.

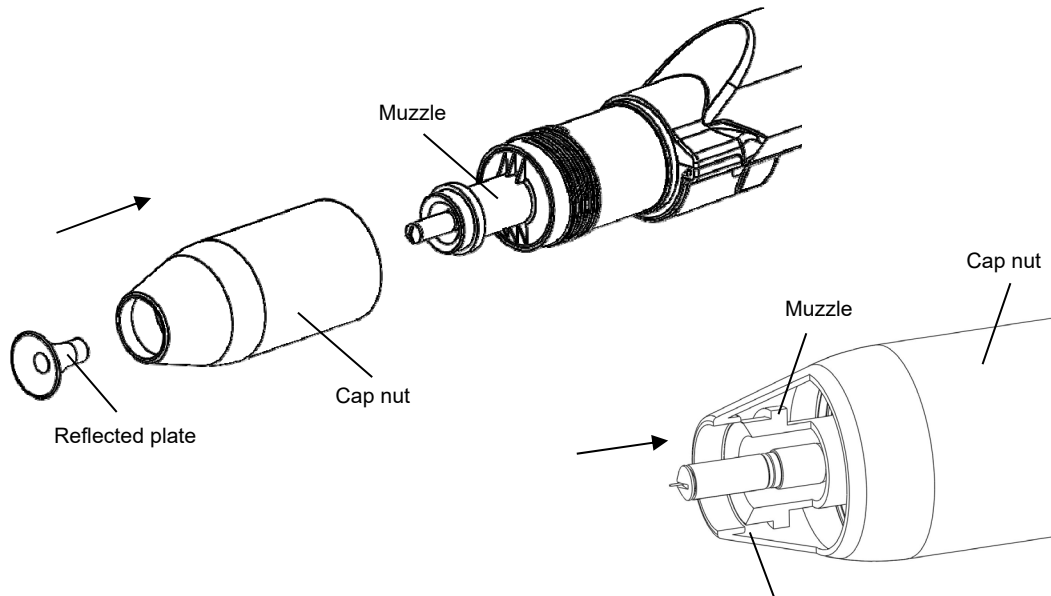

CAUTION) There is little clearance between the cap nut and the muzzle, so forcefully tightening the cap nut may cause interference and damage. View the gun from the front and tighten the cap nut while making fine adjustments.

5

Paint Preparation and Paint Work

5.1 Paint Supply

Supply paint from the powder paint feeder.

NOTE

Refer to the instruction manual of your paint feeder for how to supply powder paint to the gun and how to set up the supply.

CAUTION

Check carefully when using any of the following paints.

- High specific gravity paint may reduce discharge.
- Paint containing hard pigments may wear the inside of the gun's paint path and the parts more quickly.
- Fine particle paint tends to stick in the paint path of the gun, so check the path when preparing coating.

5.2 Spray Distance

Too far spray distance reduces electrostatic effects while powder paint particles are blown by impacts of transfer air in too close distance. The paint transfer efficiency declines in either case. Moreover, electrostatic sparks may be generated if the gun is rapidly brought closer to the object to be coated while high voltage is applied.

Paint in a spray distance suitable for the voltage of the gun tip.

(The spray distance should be 200 to 300 mm as guideline.)

WARNING

Risk of ignition with electrostatic sparks

- Maintain a suitable spray distance during electrostatic paint works. Pay particular attention not to bring the gun rapidly close to a grounding conductor.
- Pay particular attention when you use powder paint containing metallic pigments or other low resistive materials. Clean the gun tip (around the discharge electrode) or a paint path inside the gun frequently to prevent metallic pigments from sticking or building up. Also, refer to recommended conditions or usage procedures from a paint manufacturer.

5.3 At Work Cancellation and at Work Completion

(1) Use air to clean inside the powder hose and leave no paint inside.

(2) Stable spray patterns cannot be achieved with paints attached on the nozzle or the electrode.

Clean regularly.

WARNING

Risk of electrification

- **Be sure to check that voltage is not applied, before cleaning the nozzle.**
- **Ground all metals in the paint booth.**

NOTE

Refer to the instruction manual of your automatic paint system for the procedures at paint work cancellation or completion.

5.4 Gun Cable/Powder Hose Bundling and Safety Precautions

Bundle and secure the gun cable, powder hose, and cleaning air tube with the magic cable tie (part No.: 316-0177), etc. Use cable racks or other means to prevent a bend around the outlet of the reciprocating pipe or other sections where the pipe can be bent down abruptly.

Bundle them loosely without tightening too much.

CAUTION

If the gun cable, air hose, or powder hose needs to be bundled up with a tape, slightly loosen the cable so that it is not pulled with tension. If the gun cable is pulled with tension and used, that may lead to disconnection.

Do not use a metal product for bundling.

CAUTION

If the powder hose is bent and used, powder paint discharge may become instable.

6

Maintenance and Inspection

6.1 Nozzle Maintenance

Periodic inspection is required for the items of the table below.

The inspection timing is only for reference and may vary according to service situations.

Inspection item	Inspection method	Inspection timing
Inspection of attached paint or wear of flat nozzle	(1) Turn off the power of the electrostatic controller. (2) Remove the nozzle tip. (3) Inspect paint attached or wear on the nozzle tip. * Clean paint on the nozzle tip if any found. * Replace the nozzle tip if it is significantly worn out. (4) Inspect paint attached or wear on the electrode holder. * Clean paint on the electrode holder if any found. * Replace the rear end of the electrode holder or muzzle ASSY if the electrode holder is significantly worn out. (5) Inspect paint attached on the discharge electrode. * Clean paint on the discharge electrode if any found.	At work completion or at occurrence of coating film failure or discharge failure
Inspection of paint attached or wear on the round nozzle	(1) Turn off the power of the electrostatic controller. (2) Remove the round nozzle. (3) Inspect paint attached or wear on the reflected plate. * Clean paint on the reflected plate if any found. * Replace the reflected plate if it is significantly worn out. (4) Inspect paint attached or wear on the electrode holder. * Clean paint on the electrode holder if any found. * Replace the rear end of the electrode holder or muzzle ASSY if the electrode holder is significantly worn out. (5) Inspect paint attached on the discharge electrode. * Clean paint on the discharge electrode if any found.	At work completion or at occurrence of coating film failure or discharge failure

WARNING

Risk of electrification

Be sure to turn off the power of the electrostatic controller before nozzle inspection.

6.2 Gun Maintenance

Inspect at completion of paint works as follows.

- (1) Turn off the power of the electrostatic controller.
- (2) Clean paint on the gun with air blow, etc.

WARNING

Risk of electrification

Be sure to turn off the power of the electrostatic controller before gun inspection.

WARNING

Risk of personal injury or accident

- **The connection cable serves as grounding and a control line for the gun as well as power supply to the gun. If it is used with damage, that may lead to fire accident or electric shock as it can be poorly connected.**
- **Check that it is not bent or damaged.**

6.3 Consumable Parts

Prepare your spare parts according to use situations, referring to the rank category of the following consumable list.

Rank classification	Part name	Part Number	Configuration unit	Page
A	DE pad	9230-1	Gun body	28
B	Holder rear end	15E1-102	Flat muzzle/ Round muzzle	10·11
	Lower pipe ASSY	9235-1		27
C	Retaining nut	8308-001	Gun body	15
	Cover	8312-002		16
	Cap nut	8311-007		18
	Joint plate ASSY	9233-1		26
D	O-ring	130-9048	Joint plate ASSY	30
	O-ring	130-1003		
	O-ring	101-9009	Lower pipe ASSY	

Rank A: Daily replacement parts

Rank B: Parts are consumed in a mid or long term.

Rank C: Parts may be damaged or lost during works.

Rank D: Parts need to be replaced at disassembly.

* Daily replacement: Please check regularly and replace if even just one of the electrode pins is worn out or missing.

* Medium to long term: Some parts may be consumed in a short period of time depending on paint, so check the consumables regularly.

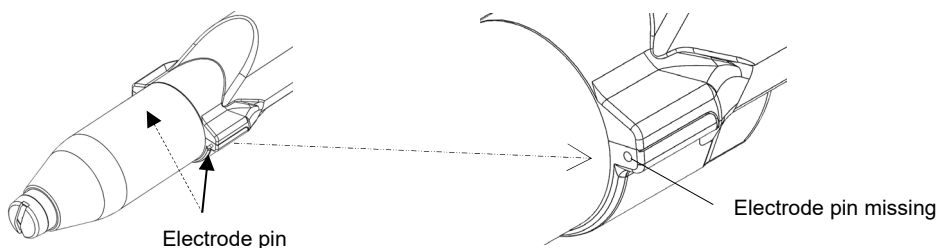

7

Troubleshooting

Multiple events or causes are seen simultaneously, depending on situations of problems.

Check symptoms carefully before taking measures.

Symptom of problem	Cause	Countermeasure
Powder paint does not discharge	Source pressure is not supplied to filter regulator.	Supply the source pressure to the filter regulator.
	Poor connection of air tube to source pressure.	Firmly insert into the filter regulator or the joint of the back side of the electrostatic controller.
	Supply air of the filter regulator is little.	Set to 0.5 MPa (dynamic pressure).
	Filter regulator failure.	Replace the filter regulator.
	Electromagnetic valve failure.	Replace the electromagnetic valve.
	Poor connection of the gun cable.	Firmly insert and fix to the gun and the connector of the control panel.
	Gun cable failure.	Replace the gun cable.
	Poor connection of the main or sub air tube.	Securely insert into the injector or the joint on the back of the electrostatic controller.
	Poor connection of the powder hose.	Firmly insert to the gun or the hose joint of the injector.
	Clogging in the gun, powder hose, or injector.	Clean or replace the gun, powder hose, or injector.
	Electrostatic controller failure.	Repair or replace the electrostatic controller.
Gun failure.	Repair or replace the gun.	
Instable discharge patterns or discharge rate.	Wear of the nozzle tip.	Replace the nozzle (flat, reflector).
	Wear of the holder rear end.	Replace the holder rear end.
	Injector insert sleeve wear.	Replace the insert sleeve.
	Clogging in the gun, powder hose, or injector.	Clean or replace the gun, powder hose, or injector.
	Wet paint or hardened paint.	Replace the paint.
	Poor connection of the main or sub air tube.	Firmly insert to the injector or the joint of the control panel.
	Poor connection of the powder hose.	Firmly insert to the gun or the hose joint of the injector.
	Low paint in paint tank.	Add paint to the paint tank.
Split discharge pattern	Paint attached on the nozzle or the electrode of the gun.	Clean the nozzle or the electrode.
	Nozzle wear.	Replace the nozzle (flat, reflector).

Symptom of problem	Cause	Countermeasure
Low paint transfer efficiency. Poor paint fixing.	Grounding failure.	Firmly mount ground wires to the electrostatic controller and the control panel. Firmly mount to the booth where Class D grounding is applied or a steel column with electric resistance of 100 Ω or less. Clean coating film peel-off on hangers or jigs of the object to be coated.
	The gun voltage is low.	Increase the gun applied voltage (kV) with the electrostatic controller.
	Too much air.	Decrease the air flow rate with the electrostatic controller.
	Faulty gun (high-voltage generator).	Repair or replace the gun.
	Nozzle installation failure.	Firmly mount the nozzle on the tip of the automatic gun and fasten the cap nut.
	Electric current fuse disconnection of electrostatic controller gun.	Replace the electric current fuse of the gun.
	Electric leak from gun.	Clean, repair, or replace the gun.
Poor paint finish.	High discharge rate.	Decrease the discharge rate (%) with the electrostatic controller.
	High gun voltage.	Decrease the gun applied voltage (kV) with the electrostatic controller.
	Close paint distance.	Increase the coating distance.
	Incorrect electric current setting.	Select according to shapes and paint conditions of the objects to be coated.
	Wet paint or hardened paint.	Replace the paint.
[Gun electric current value] (1) The indication remains as 0 μA.	Poor connection of the gun cable.	Firmly insert and fix to the gun or the connector of the control panel.
	Gun cable failure.	Replace the gun cable.
	Faulty gun (high-voltage generator).	Repair or replace the gun.
	Grounding failure.	Firmly mount ground wires to the electrostatic controller and the control panel. Firmly mount to the booth where Class D grounding is applied or a steel column with electric resistance of 100 Ω or less. Clean coating film peel-off on hangers or jigs of the object to be coated.
	Electrostatic controller failure.	Repair or replace the electrostatic controller.

Symptom of problem	Cause	Countermeasure
(2) Gun electric current not increasing.	Low setting value for gun electric current.	Increase the gun current setting with the electrostatic controller.
	Faulty gun (high-voltage generator).	Repair or replace the gun.
	Grounding failure.	Firmly mount ground wires to the electrostatic controller and the control panel.
		Firmly mount to the booth where Class D grounding is applied or a steel column with electric resistance of 100 Ω or less.
	Clean coating film peel-off on hangers or jigs of the object to be coated.	

8

Replacing Parts

See the procedures below for parts replacement and repair.

! WARNING

Risk of personal injury or accident by unexpected motions of the coating machine
Be sure to shut off compressed air that is supplied to the gun before parts replacement or repair. Turn off the power of the electrostatic controller and eject and clean paints from the paint route.

8.1 Nozzle Replacement

- (1) Refer to 4.6 Nozzle installation in Chapter 4 "Preparing Equipment" and remove and replace the nozzle.

8.2 Joint Plate ASSY Replacement

- (1) Remove the four hex. socket head cap screws fixing the joint plate ASSY and pull the plate back.
 - * Do not pull it forcibly because the cable may be disconnected.

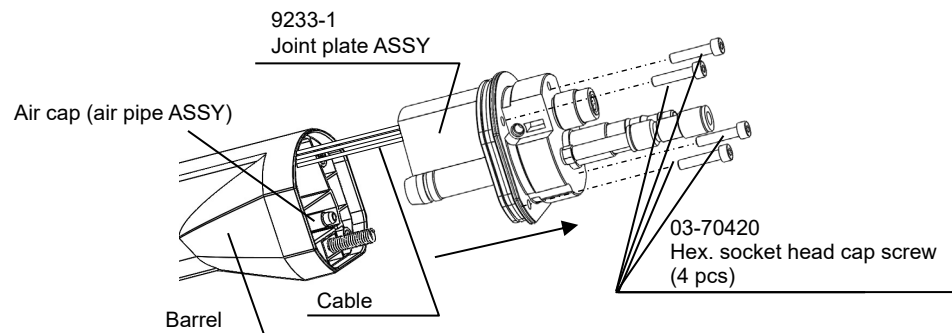

- (2) When installing, insert the joint plate ASSY into the barrel and tighten the hex. socket head cap screws not to press the cable and air cap.

* The risk of pressing can be reduced by pulling out the air pipe ASSY once and then temporarily inserting it into the air cap hole.

<Air pipe ASSY is fully inserted>

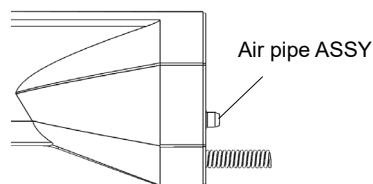

<Temporary inserted state>

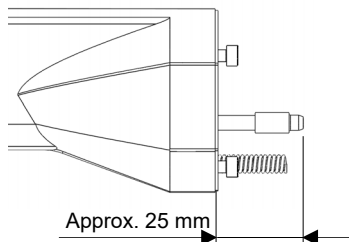

Stow the cables in the barrel without pressing them.

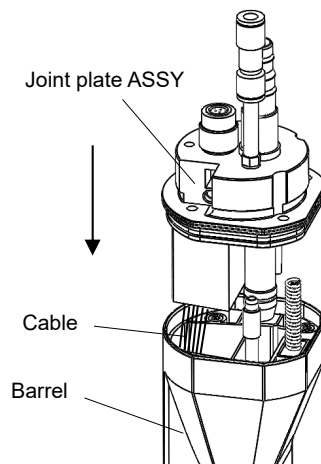

Fix the position of the spring and then insert the air cap into the hole of the joint plate ASSY as adjusting it with your fingers.

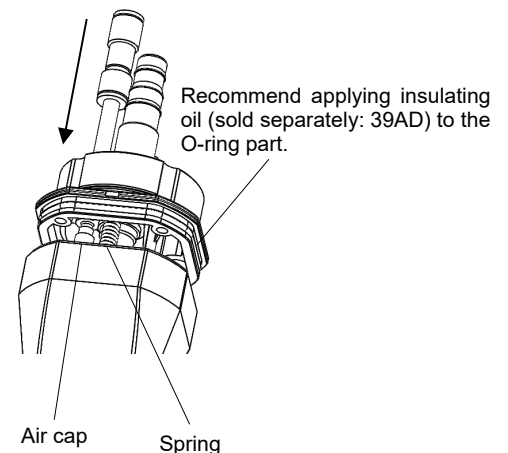

* Even if the air pipe ASSY is completely disengaged, it will be inserted by the joint plate ASSY to its proper position.

If the connector (black) comes off, please note the following when reattaching it.

⚠ CAUTION

Please note the following when inserting the connector (black) into the cascade.

First, pass the packing and connector packing through the connector (black). Hold the connector so that the three wires are on the top (orange, red, and brown from the left), and hold the cascade in the direction shown in the diagram below. Insert 8 pin heads into the 8 holes in the connector that do not have mis-insertion prevention plug, and make sure it inserted all the way to the base. If you insert it in the wrong direction, the device will not function properly. Insert it forcibly, the parts will be damaged.

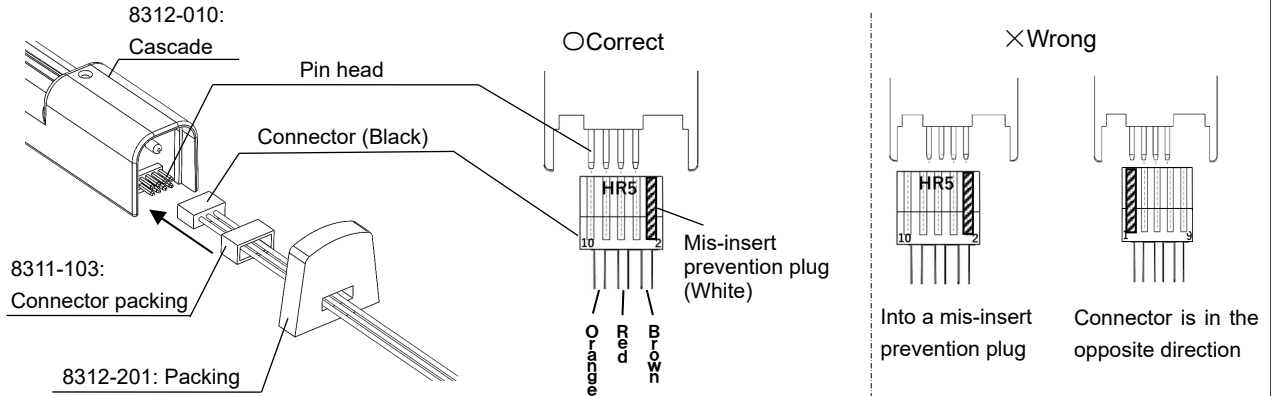

8.3 Lower Pipe ASSY Replacement

- (1) Remove the joint plate ASSY and remove the lower pipe ASSY by removing the snap ring that secures it.

Replace the O-rings (101-9009; 2 pcs) attached to lower pipe ASSY if damaged.

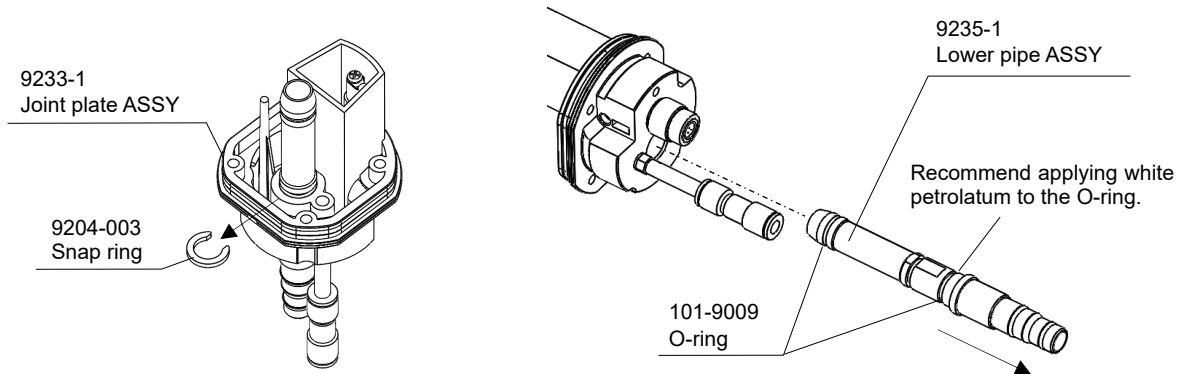

- (2) Insert the replaced lower pipe ASSY into the joint plate and fix it with the snap ring. After fixation, attach the joint plate ASSY to the barrel as in 8.2 (2).

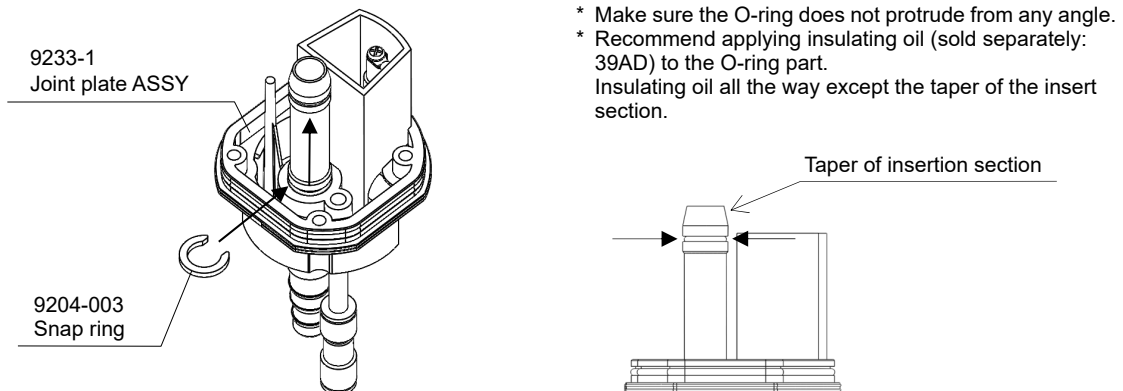

8.4 DE Pad Replacement

(1) Remove the DE pad from the gun body after removing the cap nut and resin screw.

When installing, make sure the DE pad spring touches the round terminal on the gun body.

*The cap nut holds the claw of the DE pad.

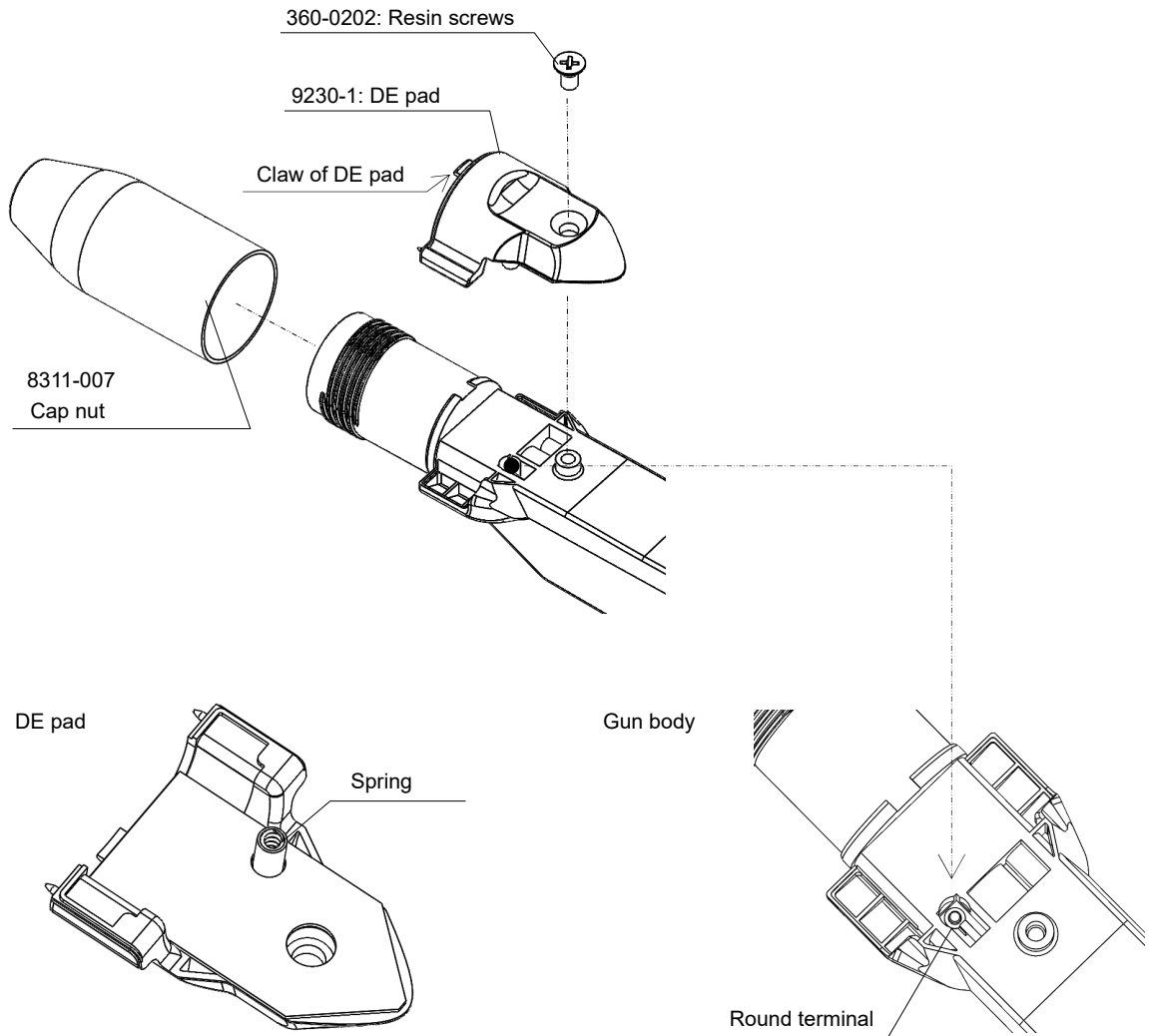

9

Component

9.1 ECDa

ECDa

8312-3

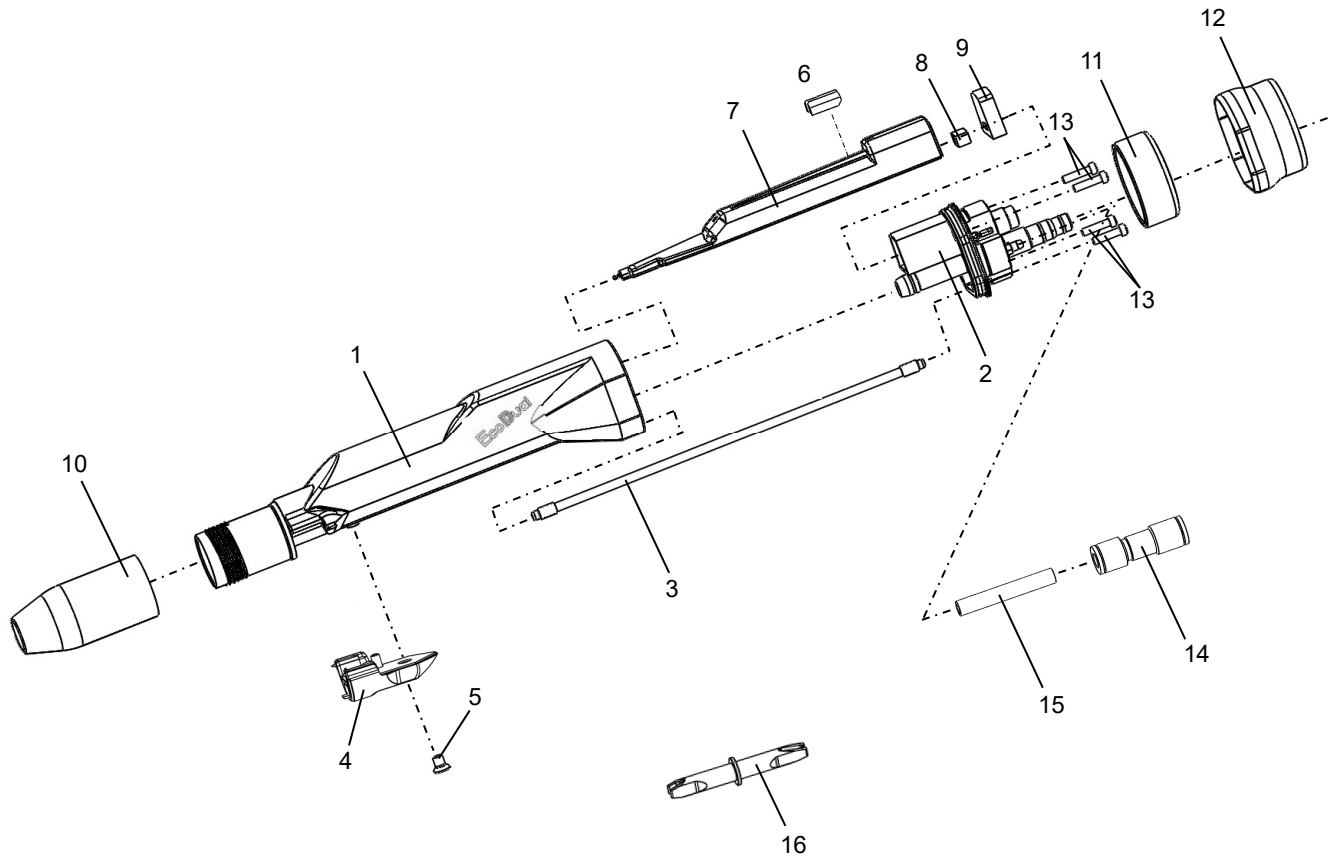

No.	Part No.	Part name	Q'ty	Remarks
1	9232-2	Barrel ASSY	1 set	
2	9233-1	Joint plate ASSY	1 set	
3	9234	Air pipe ASSY	1 set	
4	9230-1	DE pad	1	
5	360-0202	Resin screw	1	
6	8311-009	Cascade retainer	1	
7	8312-010	Cascade	1	
8	8311-103	Connector packing	1	

No.	Part No.	Part name	Q'ty	Remarks
9	8312-201	Packing	1	
10	8311-007	Cap nut	1	
11	8308-001	Retaining nut	1	
12	8312-002	Cover	1	
13	03-70420	Hex. socket head cap screw	1	M4×20L
14	380-0600	Quick joint	1	
15	586-00004	Urethane tube	1	40 mm
16	8906-102	Swap tool	1	Special tool

9.2 Component Assemblies

Joint plate ASSY

9233-1

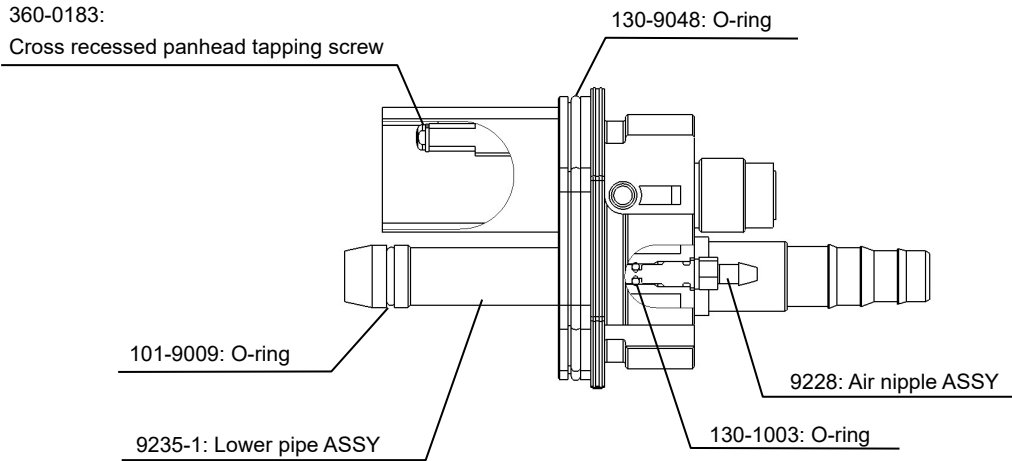

* When replacing (purchasing) the lower pipe assy, please also replace 101-9009 O-ring.

Air pipe ASSY

9234

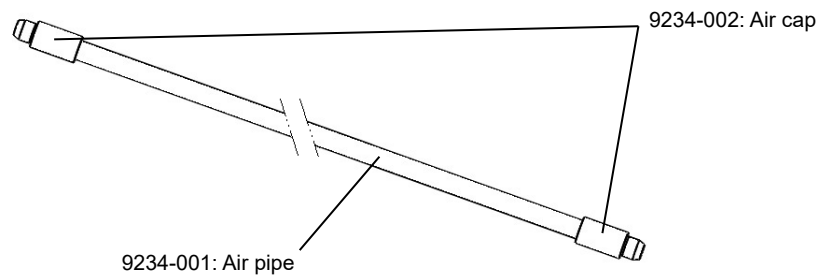

Lower pipe ASSY

9235-1

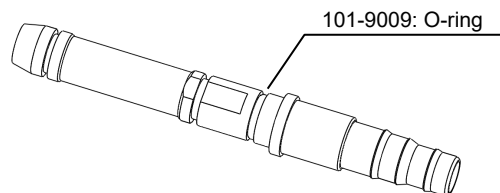

ASAHI SUNAC CORPORATION (the “Company”) shall provide the original purchaser (the “Purchaser”) with warranty service for a period of one (1) year from the date of purchase of the product, as follows:

- Should you find defects in design or workmanship with regard to parts, ship them back to the Company, with freight prepaid. The Company shall repair or replace the parts free of charge and reimburse the freight charges, provided that, as a result of an inspection and investigation of the parts conducted by the Company, the defects are deemed to be attributable to the factors within the Company’s responsibility.
- In the following cases, free after-sales service is not provided.
 1. Failure resulting from an inappropriate method of installing this equipment.
 2. Failure resulting from a use method not conforming to this instruction manual or mishandling.
 3. Failure resulting from insufficient maintenance management of this equipment and incorrect handling such as non-conformance to the procedures specified in this instruction manual.
 4. Failure resulting from unauthorized alteration or structure change of this equipment without the Company’s consent.
 5. Failure due to force majeure such as earthquake, disaster, flood disaster or lightning.
 6. Warranty for consumables worn or deteriorated even in the case where this equipment is used correctly.
 7. Repair after the machine has been used outside Japan, and shipping cost.
 8. In addition to the above, failure due to circumstances beyond our control.
- As for items such as parts purchased by the Company from another manufacturer, the warranty of that manufacturer shall apply.
- As for any parts deemed to be defective, the Company shall not be held liable for any expenses beyond the provision of repair or replacement parts free of charge.
- The Company shall not be held liable for any damage to the Purchaser caused by factors not attributable to the Company, such as misuse of product, etc.

-
- When a transfer of title of this equipment takes place, please see to it that this Operation and Maintenance Manual is handed over to the new owner.
 - This equipment is manufactured in compliance with the Laws and Regulations of Japan.
In the rare eventuality of this equipment being used outside Japan, compliance with the safety standards of the relevant countries is of course mandatory.
-

13th Edition: March 27, 2026

ASAHI SUNAC CORPORATION

HEAD OFFICE
5050, SHINDENBORA, ASAHIMAE-CHO,
OWARIASAHI, AICHI PREF. 488-0852, JAPAN
PHONE +81-561-52-0717 FAX +81-561-54-8847

URL : www.sunac.co.jp
E-mail : ctrd01@sunac.co.jp

Sales office



English



Chinese

13th Edition: March 27, 2026