

Operation and Maintenance Manual

PNEUMATIC DIAPHRAGM PUMP

Model PD40
(Standard Type)

Model PD40L
(Fine Cleaning Type)



PD40



This manual contains important information on warnings and cautions. Read the manual thoroughly before starting to operate the pump, and follow the instructions.

Always keep the manual handy until such time as the pump is no longer being used.

If your manual is lost or worn badly, do not hesitate to contact our agency which is closest to you, or the Asahi Sunac Corporation, directly, and ask us to send you a new one.

Thank you for buying our product.

Dear Valued Customer,

Thank you for buying our product, PD40.

Please read this manual carefully before starting to operate the pump. Please pay particular attention to major specifications, warnings and precautions, including prohibited items. Use the pump appropriately and with care, following the instructions. We hope that by doing so you win benefit from use of the product over a long period of time.

The pump is geared to industrial painting. It is for use only by those who are familiar with its workings and have undergone proper training; persons without such knowledge should not be allowed to operate the pump.

Should you have any questions with regard to the manual, please give us the "Model Name" and "Serial Number" of your equipment, so that we may be able help you with your questions. You can reach us at any of the addresses, phone numbers and fax numbers shown on the back cover.

Thank you,
Asahi Sunac Corporation

Contents



1	For Your Safety	1
2	Equipment specifications and components	4
3	Before You Start : General Precautions	5
4	Operation: Procedures and Precautions	6
5	Maintenance and Periodic Inspections	9
6	Useful Tips	9
7	Tear-Down Inspection and Replacement of Parts	10
8	Troubleshooting	13
9	Exploded Diagram and Part Names	14
10	Maintenance Log	18
11	Warranty	19

Please read and understand this manual. Always follow the instructions in it. Failure to do so may **result in injury to the user, or damage to equipment.**

The manual contains only minimum safety precautions and no implication is intended that other measures are unnecessary. Needless to say, regulatory and corporate safety rules and regulations must invariably be observed.

Shown below are minimum basic safety precautions in connection with use of our product:

● **The safety precautions are divided into three (3) categories, based on the degree of severity of the hazard:**

	WARNING	Indicates a potentially hazardous situation which, if not avoided by following the instructions given, could result in injury.
	CAUTION	Indicates a potentially hazardous situation which, if not avoided by following the instructions given, could result in damage to equipment.
	NOTE	Indicates general safety rules, including key practices and useful tips

※ A potential hazard classified into the CAUTION category could still bring about serious results, depending on the circumstances. Always follow precautionary instructions issued to protect you and the equipment from potential injury or damage.

WARNING

Potential Hazards: Misuse

<<General safety precautions>>

- Never attempt to change component parts or modify the pump without prior consultation with Asahi Sunac. Any attempt to do so may result in equipment failure.
- Conduct periodic, and thorough inspections of the equipment, and repair and replace parts, as required.
- When spraying, ALWAYS use Personal Protective Equipment, such as protective goggles, working clothes, and/or means for breathing protection, as recommended by a manufacturers of paints or solvents. Depending on the chemical contents of the paint or solvent, and the ventilation system used, a different type of Personal Protective Equipment may be required. Please consult with the maker of the paint, or solvent concerned.
- Never leave the pump unattended while it is running. Keep children, and other unauthorized people well away from the painting equipment.

<<Compatibility of paint and solvent>>

Make sure that any fluid, any mixture of paint and solvent used, is chemically compatible with the material of the part of the pump with which it is likely to come into contact. Before use, carefully consider makers, and confirm whether or not it is compatible.

WARNING

Potential Hazards: Fires and Explosions

<<Sources of fires>>

As liquid paint flows through pumps and hose, static electricity is generated.

If painting equipment is not properly grounded, sparking may occur due to static electricity.

If sparks come into contact with spray paint particles, floating dust, or other inflammables the sparks could cause a fire or an explosion, possibly causing serious injury to the user and/or damage to the equipment.

- Provide good ventilation in the vicinity of spraying operations.
- Never conduct painting operations in the vicinity of a source fire, a pilot lamp, or other inflammables.
- When cleaning the painting system,
Always: Remove the nozzle, Point the tip of a spray gun at a grounded metal paint can,
Keep part of the gun in contact with the can, and
Pull the trigger for cleaning.
- Ensure that the painting equipment and workpiece are properly grounded. If they are not grounded, a fire or an explosion could result, caused by static electric discharge or sparking.
- Interrupt painting operations at once if you feel static electric shock, no matter how slight it might be. Check the equipment for grounding. Don't resume operations until you clarify the cause, and take appropriate countermeasures.
- Always keep handy a powerful fire extinguisher in the spray painting area.

<<Grounding>>

To remove potential static electricity hazards, ensure that the pump, the workpiece, and all other items within the painting system (including other equipment in use near by) are grounded. If you find something that is not properly grounded, ground it in accordance with the grounding methodology specified by Electrical Equipment Technical Standard (Class D or equivalent). The grounding method for each item within the painting system is as follows:

- Pump
Connect a ring crimp terminal (that comes with the equipment) to the pump grounding terminal (⊕), and then connect the other clip to a Class D grounding object.
- Air compressor
Arrange grounding in accordance with the maker's instructions.
- Painting hose
Use a properly grounded hose.
When using an extension hose, ensure that it is securely grounded.
- Spray gun
A spray gun connected to a hose and pump that have been properly grounded, is itself deemed to be properly grounded.
- Workpieces
Always remove dirt from hangers and grounding clips in order to keep workpieces grounded.
- Paint container
Among paint containers, only those made of a conductive metal should be placed on a grounded floor or table. For details, refer to the local regulatory requirements, and comply.
- Cleaning solvent can
Among the solvent cans, only those made of a conductive metal should be placed on a grounded floor or table. Do not place the conductive metal can on a non-conductive sheet, such as paper or corrugated fiberboard. Before you pull the trigger for pump cleaning, or to reduce pressure, ensure that the metal portion of the gun is in contact with the grounded container, and securely supported.

WARNING

<<Solvents>>

- Never use a halogenated hydrocarbon solvent: When such a solvent comes into contact with an aluminum, or plated, portion of the painting equipment, it will react chemically in a way that is very dangerous.
- Further, such a solvent may explode upon coming into contact with an aluminum, or plated, portion of a pressure vessel (pump, heater, filter, valve, gun, etc.), on occasions leading to death or injury.

● Some examples of halogenated hydrocarbon solvents

Chlorines	Trichloroethylene, Tetrachloroethylene, Ethylene chloride
Bromines	n-Propyl Bromide
Carbon-fluorines	HCFC-225, HFC-43-10mee, HFE-449s1(HFE-7100)

(Please note that the above examples do not cover all halogenated hydrocarbon solvents. Please contact a paint maker for further details.)

WARNING

In an atmosphere contaminated with paint- or spray-mist, you may suffer from respiration difficulties or you may even be intoxicated from organic solvents contained therein.

- Do not use the painting system in a room, tunnel, tank, etc., where ventilation is poor.
When you do use it, make sure that no people or livestock are within a vicinity where they may be affected.

2

Equipment specifications and components

Model	PD40	PD40L
Pressure ratio	1:1	
Fluid displacement	60mL/cycle	
Maximum output	20L/min (Liquid: water, per pump)	10L/min (Liquid: water, per pump)
Normal flow rate ※	1.8L/min	0.9L/min
Maximum air pressure	0.7MPa	
Maximum paint outlet pressure	0.7MPa (at pump outlet)	
Maximum fluid temperature	60°C	
Noise	72dB/A (at 0.7MPa)	
Air intake diameter	G1/4(PF1/4)	
Paint outlet diameter	Pump outlet diameter Rc3/8(PT3/8) (Low pressure regulator outlet diameter G1/4 (PF1/4))	
Suction hose I.D.	φ12.7mm	φ6mm
Weight	8.5kg	
Dimensions	690mm (H) x 470mm (W) x 540mm (L)	

※ If you operate beyond the normal flow rate, the consumable parts may need replacement early. In addition, it may cause spray defect and abnormal parts wearing due to the cavitations depending on the kinds of paints.

● **Pump output diagram** { — Pump only (PD40)
 { Pump only (PD40L)}

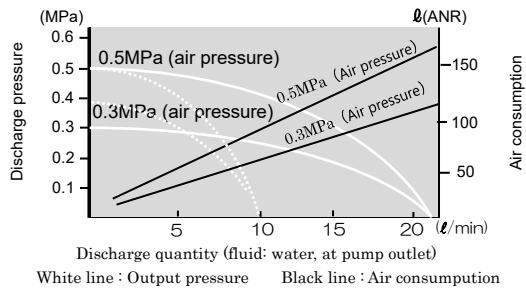

● **Standard component parts**

Pump body	1 set
Low pressure regulator	1 set
Air regulator	1 set
Suction hose	1 set
Return hose	1 set
Stand	1 set

● **Standard components and names of parts**

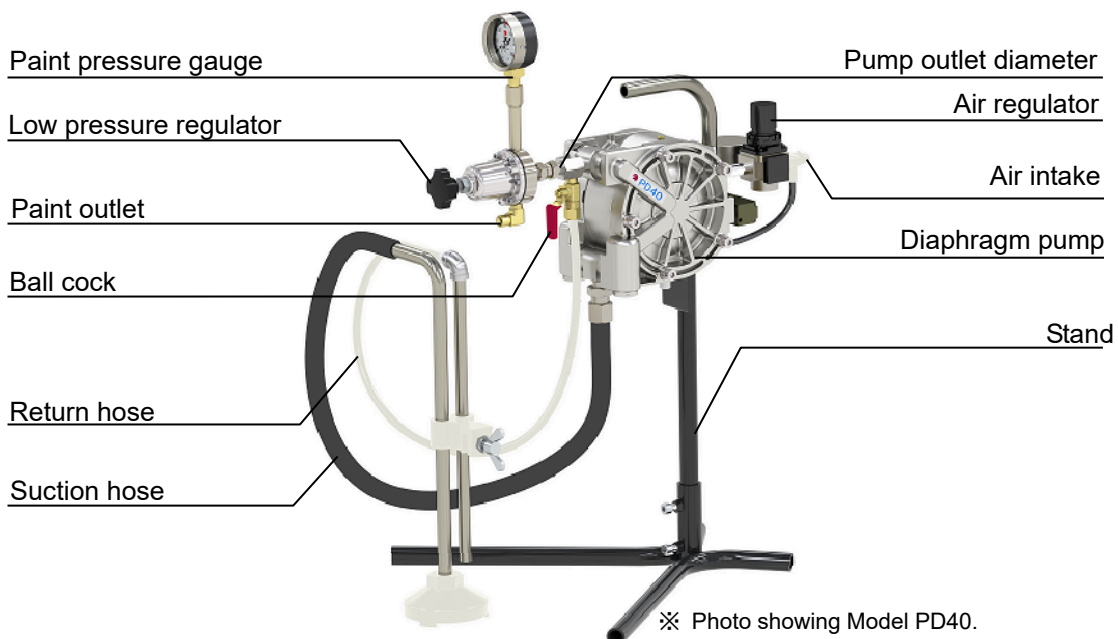

※ Photo showing Model PD40.

※ A hexagonal bar wrench (6 mm) is included as a tool for assembling the stand. (Reference: P.6)

3

Before You Start: General Precautions

- ① This diaphragm pump uses compressed air as a power source.
The compressor should have a capacity no smaller than 1.5KW (2PS)
- ② Power source air should be free of dust or impurities, which need to have been removed by means of air dryer or an air filter, etc.
- ③ When using oil-free air, in which oil has been removed by an oil-mist separator or a mist filter, be sure to install a lubricator * (oiler) in the air supply line for continuous lubrication.

* Lubricator (oiler) part No.: 302-0007

●Specified oil JIS K2213-Class 2

Similar to SAE-10	Turbine oil ISO VG32
Idemitsu Kosan	Daphne Turbine Oil 32
Cosmo	Cosmo Turbine Super 32
Showa Shell	Turbo Oil T32
JX Nippon Oil & Energy Corporation	Turbine Oil 32
Mobil	Mobil DTE Oil Light

- ④ Pressure drop may occur when a compressor is installed in a place far removed from where air is used. Arrange an optimum layout in, taking into accounts the compressor capacity and the place in which it is to be installed.

NOTE

For proper operation, the equipment requires a compressed air pressure of no less than 0.3MPa.

- ⑤ The construction of this diaphragm is simple and not many parts are used. However, if you find that the pump is not functioning in the way it should, or displaying symptoms of failure, make an adjustment or repair in accordance with “Tear Down Inspection and Parts Replacement (pages 8 – 10)” and “Troubleshooting (Pages 11).”
Having done all this, if you find that the problem is still unresolved, do not do anything further on your own initiative, but rather call immediately our local agency, or Asahi Sunac directly for complete repair at our factory.
- ⑥ For a paint that deposits quickly, stir well before use, or use a stirrer.
- ⑦ Once a painting operation has been completed, you can either leave paint in the pump or remove it completely from the pump by means of cleaning. If you clean it, clean it completely. If you don't, just don't do anything. Leave it alone. In any case, don't clean the pump in a half-baked fashion. That is the worst thing you could do to the pump: the residual paint in the pump, left over from cleaning, would eventually harden, hampering suction capability and leading to a deterioration in painting performance.
- ⑧ Because of the way that the pump is constructed, no paint containing bone materials in it should be used.
- ⑨ Please note that, when using a paint with highly abrasive grains, such as a zinc-rich paint, there may be occasions where the life of ball, seat and diaphragm gets shorter than otherwise.
- ⑩ A snap-action type pilot valve is used for this pump. For this reason, when the pump stops at a stroke end (the right end or the left end), the pilot valve air will be continuously discharged. This does not mean that there is a failure, it is perfectly normal.

CAUTION

Please do not remove the suction filter or filter. There is a possibility of the diaphragm damage by the foreign matter mixing when removing and using it.

CAUTION

Please use the socket (3206-009-1) for the pump exit Rc(3/8). When a small fitting of screw effective diameter is used, the movement of the ball (3701-022) is obstructed, and it causes pump defective operation.

4

Operation: Procedures and Precautions

① Unpacking, mounting and hooking up

The Diaphragm Pump Model PD40 is for operation, and has been thoroughly inspected at the Asahi Sunac Plant. The only things you have to do is set up a stand and to connect a hose and gun, and you are all set to go. Having said that, when you receive shipment from us, you should inspect the equipment and parts immediately following unpacking, for they may have been subjected to vibration in transit. Check to see if there has been any damage to the equipment or parts, if any portions have become loose, or if any parts are missing. If you discover any damage or that parts are missing, please get in touch with our agency, or with Asahi Sunac direct.

(1) Upon unpacking, check the equipment and parts against the packing slip.

For your reference, page 4 shows a typical packing slip with standard parts.

(2) Assemble the stand.

Follow these steps.

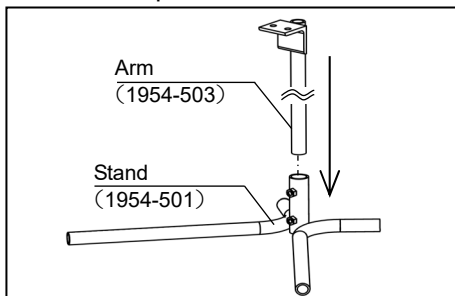

1. Insert the arm into the hole of the stand.

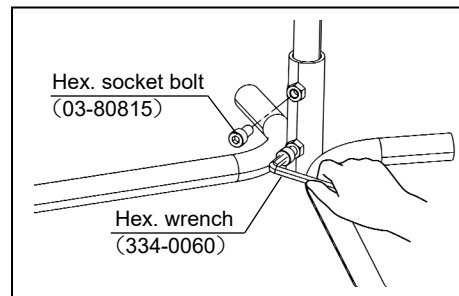

2. Insert the hex socket bolt and tighten using a hex wrench.

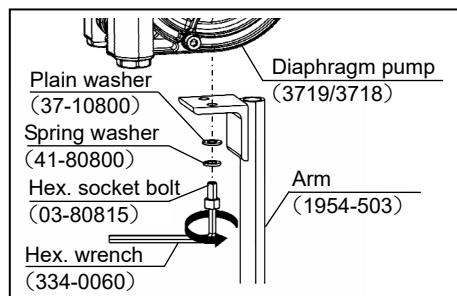

3. Secure the diaphragm pump and arm.

Insert the flat washer, spring washer and hexagon socket head cap screw and tighten them using a hexagon bar wrench.

(3) Attach the low pressure regulator securely to the paint outlet joint referring to the picture on page 4.

(4) Hook up the paint hose to the paint outlet of the low pressure regulator, and then the spray gun to the hose.

(5) Turn the air regulator handle counterclockwise, loosening it to the maximum extent possible.

② Method of operation

Clean the inside of the equipment with solvent (cleansing thinner). Operate each function to check that if everything is OK.

⚠ WARNING

Check the paint passage for leaks. If you find any leak, turn the air regulator handle counterclockwise immediately, shutting off the air pressure. Then re-tighten the joint at which you have noticed the leak.

⚠ CAUTION

When you use thinner, turn on the ventilator.

If you find foreign matters in solvent, remove it. Foreign matters inside the pump will cause clogging and painting failure. Please follow the following procedure to prepare for operations.

- (1) Pour around 3 liters of solvent into a paint can (container). And put the suction member into it.
- (2) Open the ball cock.
Slowly turn the air regulator handle clockwise (open). As compressed air starts coming in, the pump will be set in motion. Let solvent discharge from the return hose for two to three minutes. Then, shut off the ball cock.

CAUTION

In order to prevent an air regulator from getting damage , unlock the handle of air regulator before operate.

CAUTION

Set the air regulator at about 0.1 MPa.

- (3) Point the spray gun into the paint can and pull the trigger. As solvent runs through the pump and paint hose, it will take any air with it along the way, making them air-free inside (air will be discharged as bubbles). Once cleaning has been completed, pull off the suction member. Open the ball cock, letting the pump run idly, removing all remaining solvent through the return hose. Close the air regulator by turning the handle counterclockwise. The above constitutes the setting up of equipment for a painting operation.

③ Operating procedure

- (1) Pour paint into a paint container.
- (2) Open the ball cock.
- (3) Slowly open the air regulator by turning the handle clockwise, setting the pump in motion.

NOTE

Set the air regulator at about 0.1MPa.

- (4) When paint comes out of the return pipe, close the ball cock.
- (5) Set the air regulator to an operating pressure.
Also set the low pressure regulator to an operating pressure -- by turning the handle clockwise until the regulator opens to the extent that is just right for the operating pressure.

NOTE

**Recommended pressure setting for normal operations:
Air regulator at 0.3MPa or more: Low pressure regulator at 0.1~0.15MPa.**

When paint viscosity is high or when you want to feed paint at a higher rate, set the air regulator to a pressure higher than normal.

CAUTION

- ① **Air purging or pressured paint feeding from the suction side of PD40·L, the paint may enter the air chamber and the pump may stop.
When performing air purging or pressured paint from the suction side, set the pressure to 0.02MPa or less.**
- ② **When paint supply runs out in the middle of operation, the system sucks air in place of paint and paint spraying operation will be disrupted with the pump running idly.
After lowering the air pressure of the air regulator and replenishing the paint, bleed the air from the ball cock and gun, and restore the pressure setting before starting work.**

④ Interrupting operation

To interrupt operation for a while,

- (1) Close the air regulator by turning the handle (counterclockwise) and stop the pump.
- (2) Make sure that air pressure is removed from the ball cock and gun.

WARNING

**Paint may flow backward, so relieve pressure from the ball cock or gun tip when operation is interrupted.
If pressure cannot be released at line, take measures such as placing a check valve to prevent backflow.**

CAUTION

When you start a diaphragm pump for the first time in a day, or when you shut it down at the end of the day's work, use the air regulator – open for starting up and close for shutting it down. Never start the compressor with the diaphragm compressor regulator valve open: should you do so, the air valve might fail, causing the pump to fail.

⑤ Changing paint colors and cleaning

- (1) -Open the ball cock.
-Remove the suction filter or filter from the paint can.
-Run the pump without a load to expel any paint that has remained inside the pump.
-Close the ball cock.
-Pull the trigger of the spray gun, expelling any paint that has remained inside the hose.
- (2) -Once paint has been expelled from the system, put the suction member into the cleansing liquid tank.
-Open the ball cock to circulate cleansing liquid for flushing.

⑥ Post-operation procedure

Having interrupted operation following the procedure as per ④, there are two kinds of post-operation procedures, (1) and (2), to choose from depending on the shutdown period and type of paint used.

WARNING

**Paint may flow backward, so relieve pressure from the ball cock or gun tip when operation is finished.
If pressure cannot be released at line, take measures such as placing a check valve to prevent backflow.**

- (1) Leave the system filled with paint.
Because no air is trapped in the paint passage, oil is kept in the system as if it were being kept in a paint can for storage, thus preserving it free from solidification. However, if the kind of paint you are using is one that deposits quickly, such as a two-liquid paint, do not keep it in the system too long. You would be better off following Procedure (2).
- (2) Keep the system paint-free.
Flush the system with cleansing solvent, thoroughly: paint, if left out, will deposit and solidify with time, no matter how small the amount is. Keep the system filled with cleansing solvent until you use the system again.

CAUTION

However, when you shut down the system for a long period of time, after flushing with water, you should also flush the system with an organic solvent. When the period of shut down is over, fill the system again with organic solvent.

5

Maintenance and Periodic Inspections

① Maintenance

- (1) Daily maintenance operations
Cleaning of gun and suction filter or filter.
- (2) 100-hour maintenance operations
Cleaning of pump and low pressure regulator
- (3) 1000-hour maintenance operations
Inspection of diaphragm, ball and valve seat

② Perishable parts replacement frequency

(1) Wet parts

Replacement frequency based on typical discharge rate at 1 liter per minute
(Valve shifting clicking sound every 2 seconds)

The numbers of parts are taken from the lists of parts in this manual.

Unit: hour

Index number	Part No.	Part name	Standard paint	Abrasive paint (ceramics, zinc, etc.)
16-6	3714-006	Diaphragm	3000 - 5000	1000 - 2000
16-16	3714-016	Seat	3000 - 5000	500 - 1000
16-17	3717-017	Valve seat	5000 - 10000	1000 - 2000
16-18	3701-022	Ball (discharge)	2000 - 4000	500 - 1000
16-18	3701-022	Ball (suction)	5000 - 10000	1000 - 2000

When changing valve seats, change O-rings (101-6012, 101-6014), as well.

(2) Air valve replacement parts

The numbers of parts are taken from the lists of parts in this manual.

Unit: hour

Index number	Part No.	Part name	Unlubricated	Lubricated
16-9	3711-009	Slider	10000	10000
16-13	3711-013	Bushing	10000	10000
16-23	314-0015	Air valve	3000	10000
16-26	130-6014	O-ring	3000	10000

The maintenance schedule described above is based on normal operating conditions. Depending on the frequency of color change and pressure setting, the inspection and frequency of replacement of parts may vary: use your own discretion for appropriate frequency.

The parts marked with ※ are perishable parts, and we recommend that you carry an inventory at all times.

6

Useful Tips

- ① When using a kind of paint that quickly deposits, such as a metallic paint, etc., slightly open the ball cock for stirring the paint, making use of short circulation.
- ② When feeding a high viscosity paint, remove the low pressure regulator to step up feeding pressure to the maximum pump output pressure (0.7MPa).

Inspect periodically diaphragms, balls, and valve seats, etc.

When you discover excessive wear or fatigue, replace the parts in accordance with the procedures shown below. Before you get down to inspection or replacement of parts, clean the pump thoroughly. And then take the parts apart.

⚠ CAUTION

Tear down inspection and replacement of parts should be carried out only by those who are well acquainted with the ways in which they should be conducted, and strictly follow the procedures designated.

① Inspection and replacement: Suction valve, ball, and valve seat

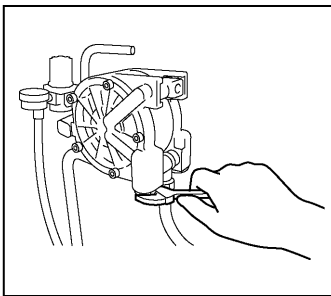

① Remove the valve seat with a 27mm spanner. There is one for each side, Left side and Right side.

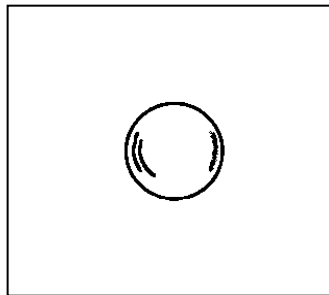

② Check the ball for deposition of foreign matter (paint, etc.), damage, and wear (see if diameter is too small in relation to normal ball diameter, 14.2mm). Replace, as required.

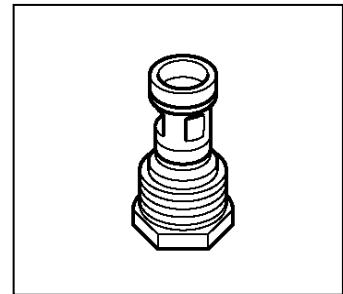

③ Check valve seat for deposits (paint, etc.) on paint passage and for damage on seat surface. If there is a deposit, clean. If there is minor damage, polish with #400 water-proof emery paper. (Polish uniformly all round). If damage is too extensive to repair, replace.

② Inspection and replacement: Discharge valve, ball, and seat

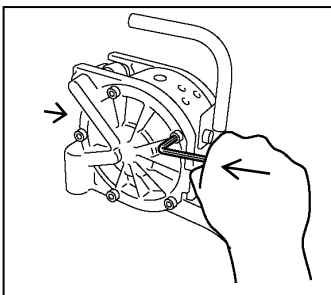

① Detach the flanges from the pump body by removing 10 flange mounting screws on both right and left sides using a 6mm hexagonal wrench. When they don't come off easily, insert a flat-tipped screwdriver into the notches shown by arrows and remove.

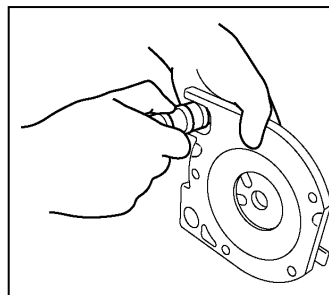

② Remove manifold from flange.

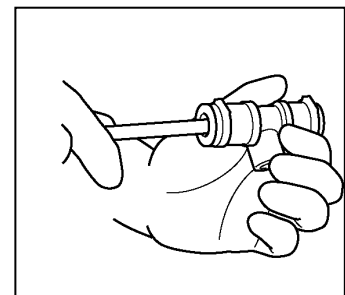

③ Push ball from one end with pencil or stick. Seat at the other end will come off with the ball. Put the ball in from the end where seat just came off and push it with a pencil or stick. Seat at opposite end will come off.

③ Inspection and replacement: Diaphragm

Removing Diaphragm

Remove flanges in accordance with the procedures per ① and ② for check valve inspection and replacement. Now, you are ready for diaphragm inspection. Check it for damage, cracks, etc.

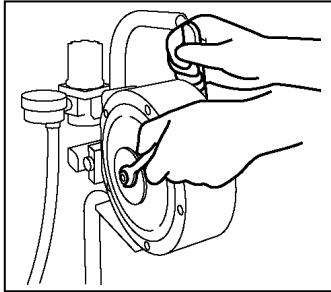

① Using two 10mm spanners on M6 nuts on both sides, remove one of the nuts.

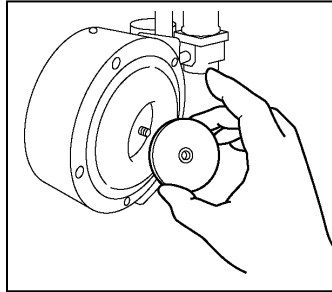

② Remove the disk, the diaphragm, and then the other disk from the side from which you have removed the nut.

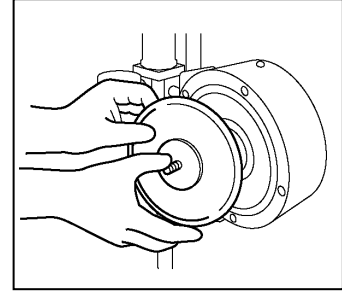

③ Remove the diaphragm on the opposite side together with the shaft.

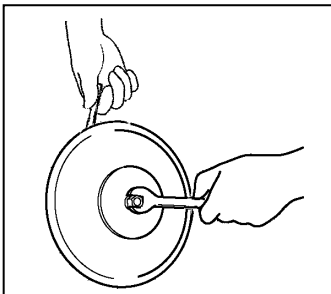

④ Put a spanner over the two opposing flat faces of the shaft nut and turn it to remove the nut.

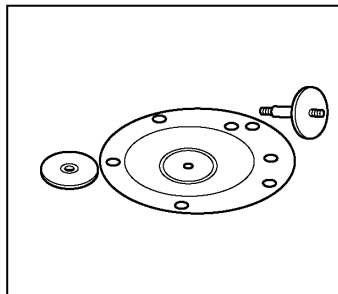

⑤ Remove the disk, then the diaphragm, and then the other disk.

Attaching Diaphragm

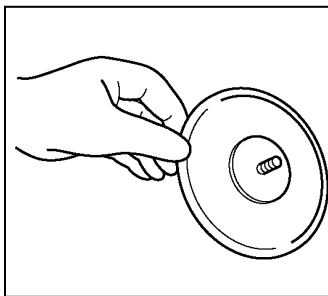

⑥ Mount parts onto the shaft in the following order: Disk, O-ring, diaphragm, other O-ring, then disk. After that, mount the spring washer and M6 nut, which for the time being should then be tightened lightly.

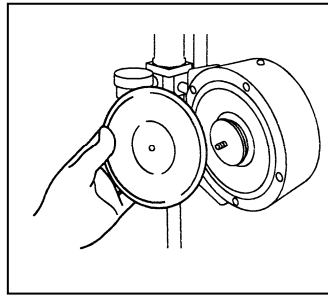

⑦ Put the diaphragm as assembled on the shaft onto one side of the pump body. Then, from the other side, install parts in the following order: disk, O-ring, diaphragm, other O-ring, disk, spring washer, and M6 nut, which for the time being should then be tightened lightly. When installing the diaphragm, make sure that the diaphragm sphere is facing the outer side.

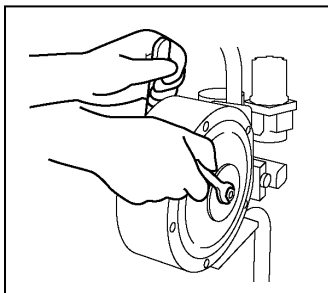

⑧ Tighten M6 nuts with two spanners. (Tightening torque: 1000N · cm) If tightening torque is not proper, trouble may result, such as a fluid flowing into the air passage.

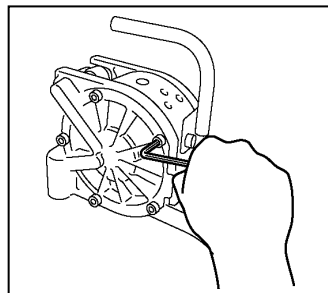

⑨ To wrap up re-assembling, mount both (Left side and Right side) flanges. (Tightening torque: 3000N · cm) If tightening torque is not proper, fluid may leak from the flange portion.

④ Inspection and replacement: Pilot valve (slider)

※Conduct an inspection only when the pump has failed.

(1) When the pump has failed, first of all, check the air valve (14-23) to see if it has stopped.

Re-open the air regulator by moving air valve control from side to side and supply compressed air.

When the slide control is too heavy, or when there is leak from mufflers (14-19) all the time, replace.

(2) When there is a continuous air leak from the muffler (14-7) on either side of the manifold (14-4) (on which the air valve is mounted), or when the air valve (14-23) frequently fails, pilot valve wear may be suspected. Inspect and repair in accordance with the following procedures:

① Shut off supply of the air to the air intake.

② Remove the diaphragm in accordance with the diaphragm inspection and replacement procedure (page 9).

③ Remove the housing (14-14), and replace the O-ring (14-26) within housing.

④ Remove the housing (14-14), and pull out of the shaft (14-10).

⑤ Replace the slider (14-9) located in the middle of the shaft (14-10) that has been pulled out.

Apply grease to the shaft (14-10), the slider (14-9), and the collar (14-11). And then, put them back on.

* A set of two numbers connected with a hyphen in parentheses () represents the page number on which the part is shown (the number before the hyphen), as well as the index number of the same part (the number after the hyphen) appearing on that page.

A set of two numbers connected with a hyphen in parentheses () represents the page number on which the part is shown (the number before the hyphen) as well as the index number of the same part (the number after the hyphen) appearing on that page.

Symptom	Probable cause	Remedy
1. No paint fluid pressure	① Failure to open air regulator (14-15-9)	① Open completely (clockwise)
	② Defective pressure gauge (14-15-13)	② Replace it with a new one
	③ Hardened paint on ball (16-18) in pump due to insufficient post-operation cleaning	③ Thoroughly clean with thinner. If it does not work, take pump apart and clean.
	④ Air valve (16-23) failure	④ Move air valve slide control from side to side. If it does not work after repeated attempts, replace.
2. No paint discharge, even when pump is still operating	① Clogged suction filter (14-8) or filter (15-8).	① PD40: Clean suction filter screen (17-3). PD40L: Clean filter (15-8).
	② Ball (16-18) stuck to seat (16-16) or valve seat (16-17), and will not detach.	② Clean seat (14-16) and valve seat (14-17)
3. Paint discharge tapering off	① Clogged suction filter (14-8) or filter (15-8).	① PD40: Clean suction filter screen (17-3). PD40L: Clean filter (15-8).
	② Clogged low pressure regulator (14-15-6)	② Take low pressure regulator apart and remove foreign matter by cleaning
	③ Clogged paint passage	③ Take it apart and clean
4. Pump does not run at uniform rate	① Clogged suction filter (14-8) or filter (15-8).	① PD40: Clean suction filter screen (17-3). PD40L: Clean filter (15-8).
	② Defective slider (16-9) seat, with continuous air leak from muffler (16-7)	② Take slider apart and clean. If you find damage on slider (16-9), replace
5. Pump failing to come to a stop after spraying has stopped	① Empty paint can (container)	① Replenish paint
	② Leak from pain passage	② Bring paint fluid pressure down to zero by turning air regulator counterclockwise, then retighten socket head cap screw with washer (16-32). (Tightening torque: 3000N · cm)
	③ Defective seat (16-16) or valve seat (16-17)	③ Clean or replace seat or valve seat
6. Air leak from muffler (18-7)	① Defective slider (16-9)	① Take slider (16-9) apart and clean. If you find damage or wear on sealed portion (black portion) of slider, replace.
	② Excessive wear of O-ring (16-26) within housing	② Replace O-ring.
7. Air gets in from outlet	① Broken diaphragm (16-6)	① Replace diaphragm When there is paint deep inside the air valve, clean the paint passage, thoroughly dry, and then replace the air valve (16-23).
	② Hexagonal nuts (16-36) of disks (16-15) that hold diaphragm from sides, loose	② Tighten hexagonal nuts If there is a paint leak from the exhaust muffler, replace the air valve (16-23).
	③ Flange (16-2, 3)- mounting hexagonal socket screws (16-32) loose	③ Tighten hexagonal socket screws. (Tightening torque: 3000N · cm)

Low pressure regulator

Symptom	Probable cause	Remedy
Paint pressure does not go up	① Clogged fluid passage	① Take it apart and clean.
	② Defective pressure gauge (13)	② Replace pressure gauge. (13)
Paint pressure does not come down	① Foreign materials on valve seat (5)	① Detach the valve (5) and remove foreign objects by air blow.
	② Worn valve (5)	② Replace valve (5).
Paint leaks from regulator handle	Broken diaphragm (4)	Replace diaphragm
Paint pressure fluctuates	Pump pressure too low	Set pressure higher (0.15~0.7MPa).

NOTE: Due to continuous improvements and modifications, the configurations and specifications of the equipment specified herein are subject to change without prior notice.

9

Exploded Diagram and Names of Parts

PD40

40362-1

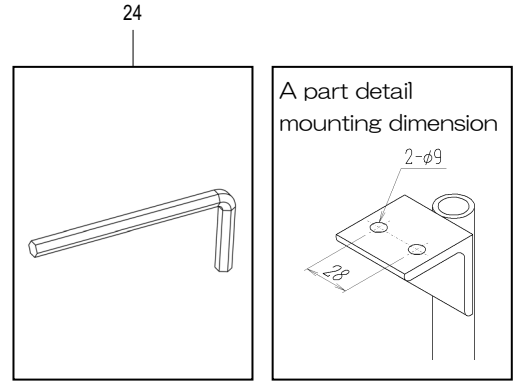
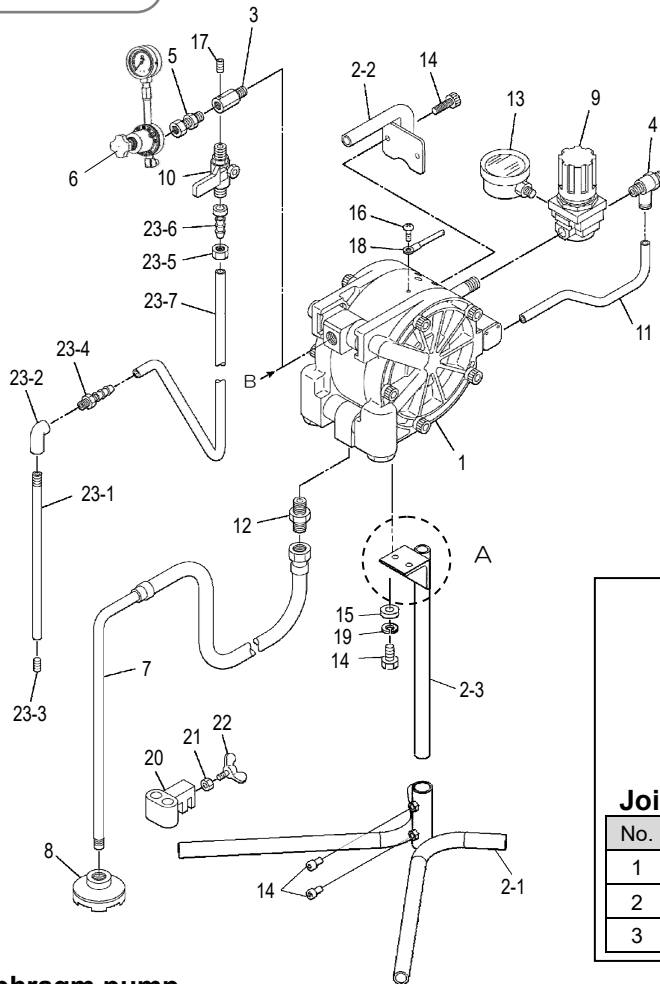

Joint for two spray gun(Optional)

No.	Part number	Part name	Qty	Remarks
1	3923-001	Fork joint	1	
2	287-2003	High-pressure nipple	1	
3	3204-122	Union joint	2	

Diaphragm pump

No.	Part number	Part name	Qty	Remarks
1	3719	Diaphragm pump (main body)	1set	
2	1954-5	Stand	1set	
2-1	1954-501	Stand	1	
2-2	1954-102	Handle	1	
2-3	1954-503	Arm	1	
3	3206-009-1	Socket	1	
4	3201-029	Hose joint	1	
5	3204-122	Union joint	1	
6	0767-1	AR70 low pressure regulator	1set	
7	5601-1	Suction hose	1set	※1
8	0501	Suction filter	1set	
9	301-0025	Air regulator	1	
10	325-0003	Ball cock	1	
11	40397-014	Air tube	1	
12	247-2304	Hose joint	1	
13	305-0003	Pressure gauge	1	
14	03-80815	Hex. socket bolt	6	※2

No.	Part number	Part name	Qty	Remarks
15	37-10800	Plain washer	2	
16	68-10410	Screw	1	
17	244-2002	Hex. socket plug	1	
18	40338-024	Grounding wire	1set	
19	41-80800	Spring washer	2	
20	40332-021	Pipe holder	1	
21	15-11000	Hex. nut	1	
22	10-61030	Wing bolt	1	
23	3444-1	Return hose	1set	
23-1	40332-201	Return pipe	1	
23-2	201-3002	Elbow	1	
23-3	244-2001	Hex. socket plug	1	
23-4	3203-012	Rubber hose joint	1	
23-5	347-0001-2	Nut	1	
23-6	347-0001-3	Joint	1	
23-7	595-0008	IRRAX hose	1	
24	334-0060	Hex. wrench	1	

※1. If you need a hose only, please order No. 52A-0008.

※2. 2 pcs of the No. 14 hexagon socket head cap screws are accessories for No. 2 stand.

PD40L

40361-1

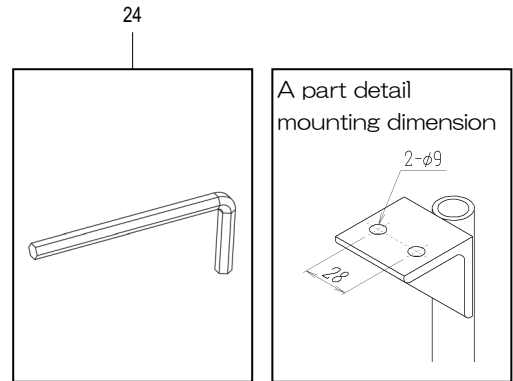
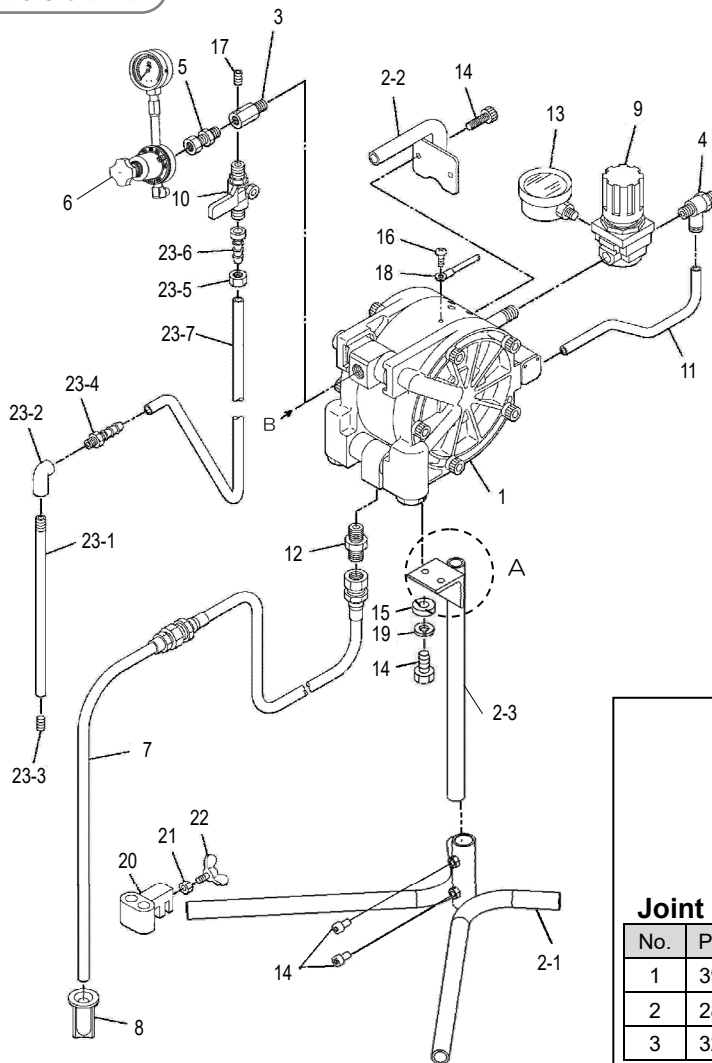

Joint for two spray gun(Optional)

No.	Part number	Part name	Qty	Remarks
1	3923-001	Fork joint	1	
2	287-2003	High-pressure nipple	1	
3	3204-122	Union joint	2	

Diaphragm pump

No.	Part number	Part name	Qty	Remarks
1	3718	Diaphragm pump (main body)	1set	
2	1954-5	Stand	1set	
2-1	1954-501	Stand	1	
2-2	1954-102	Handle	1	
2-3	1954-503	Arm	1	
3	3206-009-1	Socket	1	
4	3201-029	Hose joint	1	
5	3204-122	Union joint	1	
6	0767-1	AR70 low pressure regulator	1set	
7	5608	Suction hose	1set	※1
8	40361-008	Filter	1set	50 mesh
9	301-0025	Air regulator	1	
10	325-0003	Ball cock	1	
11	40397-014	Air tube	1	
12	247-2202	Hose joint	1	
13	305-0003	Pressure gauge	1	
14	03-80815	Hex. socket bolt	6	※2

No.	Part number	Part name	Qty	Remarks
15	37-10800	Plain washer	2	
16	68-10410	Screw	1	
17	244-2002	Hex. socket plug	1	
18	40338-024	Grounding wire	1set	
19	41-80800	Spring washer	2	
20	40361-023	Pipe holder	1	
21	15-11000	Hex. nut	1	
22	10-61030	Wing bolt	1	
23	3444-1	Return hose	1set	
23-1	40332-201	Return pipe	1	
23-2	201-3002	Elbow	1	
23-3	244-2001	Hex. socket plug	1	
23-4	3203-012	Rubber hose joint	1	
23-5	347-0001-2	Nut	1	
23-6	347-0001-3	Joint	1	
23-7	595-0008	IRRAX hose	1	
24	334-0060	Hex. wrench	1	

※1. If you need a hose only, please order No. 502-0008.

※2. 2 pcs of the No. 14 hexagon socket head cap screws are accessories for No. 2 stand.

Diaphragm pump

PD40<3719>

Diaphragm pump

PD40L<3718>

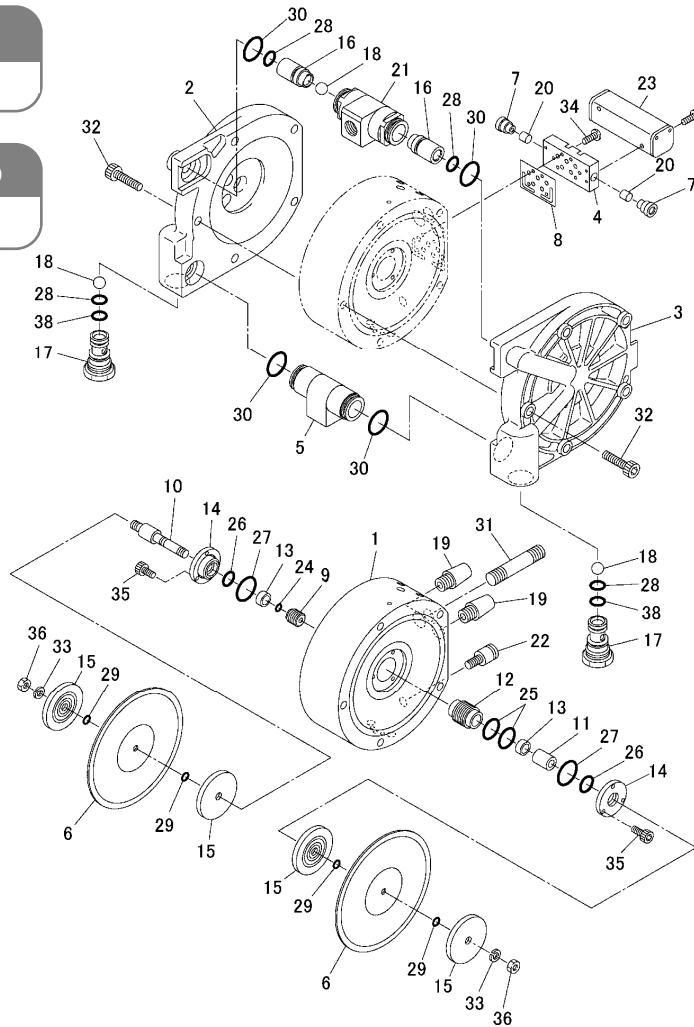

Diaphragm pump PD40<3719>, PD40L<3718>

No.	Part number	Part name	Qty	Remarks
1	3714-001	Body	1	
2	3719-002	Flange	1	
3	3719-003	Flange	1	
4	3711-004	Manifold	1	
5	3717-005 3718-005	Manifold	1	PD40 PD40L
6	3714-006	Diaphragm	2	
7	3711-007	Muffer	2	
8	3711-008	Packing	1	
※9	3711-009	Slider	1	
10	3711-010	Shaft	1	
11	3711-011	Collar	1	
12	3711-012	Guide	1	
13	3711-013	Bushing	2	
14	3711-014	Housing	2	
15	3711-015	Disk	4	
16	3714-016	Seat	2	
17	3717-017	Valve seat	2	
18	3701-022	Ball	3	

No.	Part number	Part name	Qty	Remarks
19	3701-014	Muffer	2	
20	3701-024	Filter	2	
21	3717-021	Manifold	1	
22	344-0004	Quick joint	1	
23	314-0015	Air valve	1	
24	130-6007	O-ring	1	
25	130-6022	O-ring	2	
26	130-6014	O-ring	2	
27	130-6025	O-ring	2	
28	101-6012	O-ring	4	
29	101-6006	O-ring	4	
30	101-6021	O-ring	4	
31	3701-041	Long nipple	1	
32	1F-80850	Hex socket bolt	10	
33	41-70600	Spring washer	2	
34	12-10312	Two-point sems screw	4	
35	03-80408	Hex socket bolt	6	
36	15-70600	Hex. nut	2	
38	101-6014	O-ring	2	

※ When ordering a Slider (Index No. 9), please also order O-ring (index No. 24) as well.

Low pressure regulator

0767-1

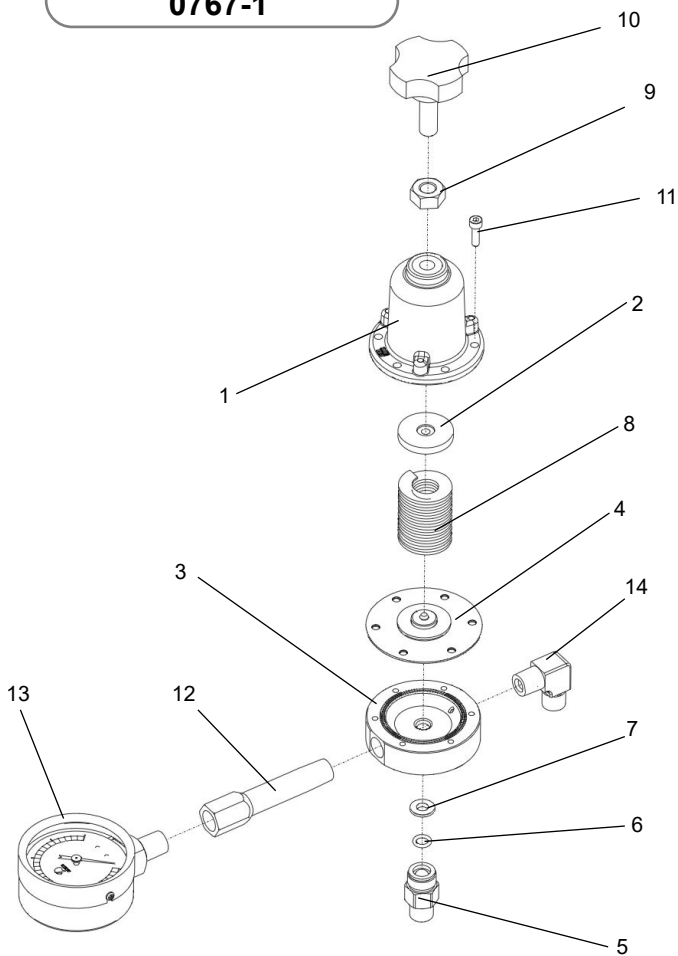

Suction filter

0501

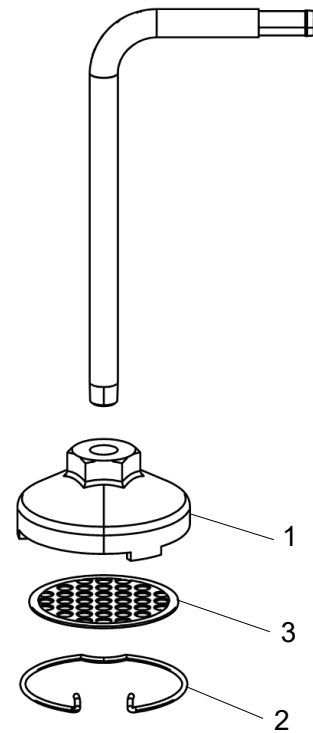

Low pressure regulator AR70<0767-1>

No.	Part number	Part name	Qty	Remarks
1	0767-001	Housing	1	
2	0740-007	Spring retainer	1	
3	0767-003	Body	1	
◆4	0767-004	Diaphragm	1	
◆5	0776-005	Valve	1	※
◆6	101-2007	O-ring	1	
7	0767-007	Gasket	1	
8	0767-008	Spring	1	
9	17-11000	Hex. nut	1	
10	0740-010	Handle	1	
11	03-70414	Hex socket hd cap screw	6	
12	0721-027	Gauge fixing nipple	1	
13	305-0011	Pressure gauge	1	
14	347-0002-1	Elbow union	1	

• Items marked with ◆ are those items that we recommend you carry in your stock.

※ When replacing the valve, replace the No. 6 O-ring as well.

Suction filter SF903<0501>

No.	Part number	Part name	Qty	Remarks
1	0501-001	Filter body	1	
2	0501-002	Snap	1	
3	0501-003-06	Screen	1set	60 mesh

ASAHI SUNAC CORPORATION (the “Company”) shall provide the original purchaser (the “Purchaser”) with warranty service for a period of one (1) year from the date of purchase of the product, as follows:

- Should you find defects in design or workmanship with regard to parts, ship them back to the Company, with freight prepaid. The Company shall repair or replace the parts free of charge and reimburse the freight charges, provided that, as a result of an inspection and investigation of the parts conducted by the Company, the defects are deemed to be attributable to the factors within the Company’s responsibility.
- In the following cases, free after-sales service is not provided.
 1. Failure resulting from an inappropriate method of installing this equipment.
 2. Failure resulting from a use method not conforming to this instruction manual or mishandling.
 3. Failure resulting from insufficient maintenance management of this equipment and incorrect handling such as non-conformance to the procedures specified in this instruction manual.
 4. Failure resulting from unauthorized alteration or structure change of this equipment without the Company’s consent.
 5. Failure due to force majeure such as earthquake, disaster, flood disaster or lightning.
 6. Warranty for consumables worn or deteriorated even in the case where this equipment is used correctly.
 7. Repair after the machine has been used outside Japan, and shipping cost.
 8. In addition to the above, failure due to circumstances beyond our control.
- As for items such as parts purchased by the Company from another manufacturer, the warranty of that manufacturer shall apply.
- As for any parts deemed to be defective, the Company shall not be held liable for any expenses beyond the provision of repair or replacement parts free of charge.
- The Company shall not be held liable for any damage to the Purchaser caused by factors not attributable to the Company, such as misuse of product, etc.

【MEMO】

-
- When a transfer of title of this equipment takes place, please see to it that this Operation and Maintenance Manual is handed over to the new owner.
 - This equipment is manufactured in compliance with the Laws and Regulations of Japan. In the rare eventuality of this equipment being used outside Japan, compliance with the safety standards of the relevant countries is of course mandatory.
-

38th Edition: July 1, 2022

ASAHI SUNAC CORPORATION

HEAD OFFICE
5050, SHINDENBORA, ASAHIMAE-CHO,
OWARIASAH, AICHI PREF. 488-0852, JAPAN
PHONE +81-561-52-0717 FAX +81-561-54-8847

URL : www.sunac.co.jp
E-mail : ctrd01@sunac.co.jp

Sales office



English



Chinese

38th Edition: July 1, 2022