

Operation and Maintenance Manual

LIGHT BEAR
for pneumatic airless coating equipment

SP1636/28(S)



SP1636



This manual contains important information on warnings and cautions. Read the manual thoroughly before starting to operate the equipment, and follow the instructions. Always keep the manual handy until such time as the equipment is no longer being used. If your manual is lost or worn badly, do not hesitate to contact our agency which is closest to you, or the Asahi Sunac Corporation, directly, and ask us to send you a new one.

Introduction

Thank you for purchasing our product High Performance Plunger Type Airless Pump LIGHT BEAR < SP1636/28(S)>.

Please be sure to read this operation manual carefully before using this product so that you can always use it under the optimum conditions.

In particular, please fully understand the items in the specifications and use them according to the correct usage.

This product is used together with a spray gun, electrostatic controller, and paint regulator.

Be sure to read the instruction manuals for each device carefully.

If you have any questions, please contact us by clearly stating the "product number" and "serial number" and contacting us on the back cover.



Please keep this operation manual in a safe place where you can easily refer to it.

Contents

1	For Your Safety ·····	1
2	Specifications, Dimensions and System Configurations ·····	8
3	Setting Up for Operation ·····	9
	General Set-up Precautions ·····	9
	Unpacking and Connections ·····	9
4	Operation ·····	11
	Operation ·····	11
	Shutdown and Equipment Care ·····	12
	Color change and additive addition precautions ·····	13
5	Maintenance ·····	13
6	Tear Down Inspection and Parts Replacement Procedure ·····	14
7	Troubleshooting ·····	16
8	Performance Tips ·····	19
9	Component Names ·····	20
10	Maintenance Log ·····	28
11	Warranty ·····	29

Please understand the contents of this instruction manual and be sure to follow the handling method. If you use it without following this instruction manual, **you may injure your body or damage your equipment and fire.**

The following safety precautions should be considered as minimum basic safety measures when using our products.

● **Precautions are displayed in the following two stages.**



WARNING

Hazards that can result in death or serious injury.



CAUTION

Danger that may result in minor or moderate injury or physical damage only.

● **Other important points are indicated as follows:**

NOTE

Observations to ensure the equipment's performance and functions are fully operational.

In addition, please observe all national and local laws and regulations related to fire, electricity, and safety, as well as the rules and regulations of your own company or business division.

«**Range of use suitable for the product**»

This product is a pump that is installed in a coating environment with an exhaust system and is used to paint and materials for application and coating.

 **WARNING**

Fire and explosion



Preventing fire and explosion in coating shop

- **Do not use halogenated hydrocarbon solvents.**
The aluminum alloy contained in this product's components may undergo a chemical reaction and explode.
- **Do not use this product outside its specifications.**
Using it out of specification range may result in a fire hazard.
- **Provide adequate ventilation with ventilation equipment.**
Volatilized organic solvents and other substances may remain and ignite, creating a risk of fire.
- **Clean the coating room and exhaust system (ducts and fans) regularly.**
If the accumulated powder simply peels off, a spark may occur, which could cause a dust explosion.
In the unlikely event of a fire, paint residue etc. will make it easier for the fire to spread and result in greater damage.



Prevent fire and electric shock caused by faulty earthing

- **All conductive objects in the coating booth (paint containers, peripheral equipment, etc.) must be grounded with an earth wire.**
In an atmosphere ionized by high voltage, poorly grounded conductors can become charged, creating a risk of fire or electric shock due to spark discharge.
The earth should be **Class D grounding or higher** (ground resistance 100 Ω or less).
- **Always keep the workpiece earthed.**
Risk of fire or electric shock due to spark discharge from charged workpieces.
- **The paint container must be grounded with an earth wire.**
The paint path can cause the paint container to become charged, a risk of fire or electric shock.
- **Be sure to periodically remove any paint that has stuck to the hanger.**
If paint adheres to the contact part between the hanger and the object, there is a risk of fire or electric shock due to poor earthing.
The ground resistance value should be 1k Ω or less for metal (1M Ω or less for resin) (measurement voltage should be 500V or more).
- **Do not place any items in the coating booth that are not necessary for coating.**
Static electricity can cause spark discharge, which can result in fire or electric shock.
- **Paint operator must take precautions to prevent static electricity.**
Static electricity builds up on the human body, causing sparks to discharge, which may result in fire or electric shock.

《Warning and precautions for safe use》

WARNING

Fire and explosion



Prevent fires caused by ignition of paints and solvents

- **Do not bring any spark-producing devices, matches, lighters, etc.**
Risk of explosion or fire due to ignition of flammable materials.

Equipment misuse



Preventing accidents caused by poor maintenance

- **Any abnormal noises or vibrations, immediately stop operation.**
Product damage may result in a fire hazard.
- **Do not operate if any parts are damaged or missing.**
Product damage may result in a fire hazard.
- **Do not use the equipment with the safety valve removed.**
Malfunction or equipment damage may cause injury to the human body.

Human protection



Protection from solvents, air and paint pressure

- **Do not spray paint towards person**
Harmful substances may cause serious injury, including inflammation and poisoning.
Pressurized paint can cause personal injury.
- **Wear protective glasses, a protective mask, and protective gloves^{*1} when handling paint.**
Harmful substances may cause serious injury, such as inflammation or poisoning.
Carefully read the safety data sheet (SDS^{*2}) of the paint you are using and take appropriate exposure prevention and protective measures.
^{*1} When using protective gloves for skin absorption protection or to prevent dirt, it is necessary to prevent static electricity from building up on the human body.
Be sure to ground it properly. (Recommended protective gloves are those specified in JIS T8118, or earth bands, etc.)
^{*2} SDS : Safety Data Sheet
- **Clean the coating room and exhaust device (ducts and fans) regularly.**
If the exhaust device does not function properly, harmful substances may cause serious injury, including inflammation and poisoning.

 **WARNING**

Human protection



Protection from moving parts

- **Do not touch the moving parts when activating the pump.**
There is a risk of fingers getting caught in the moving parts, causing injury to the body.
- **When interrupting or ending work and before cleaning, disassembly and maintenance, stop the supply air to the pump. Be sure to release the pressure.**
The pump may activate unexpectedly, posing a risk of injury if fingers become trapped in moving parts (such as the piston rod).
There is a risk of serious injury, such as inflammation or poisoning symptoms, due to hazardous substances.
- **Do not leave the site while the pump is operating.**
If someone is unaware that the pump is running, there is a risk of their fingers getting caught in the moving parts (piston rod, etc.) and sustaining personal injury.



Protection from high-pressure paint

- **Always use below the maximum output pressure.**
If paint or materials are sprayed out of the equipment and enter the body through the eyes or mouth, there is a risk of serious injury such as inflammation or poisoning due to the harmful substances contained in the paint or materials.
- **Do not use paints or materials that are not intended for this product.**
Deterioration due to heating, chemical reaction, or container alteration may cause the equipment to burst, and there is a risk of injury to the human body from fragments, pressurized paint or materials.
Harmful substances can cause serious injury such as inflammation and poisoning.
Deterioration due to heating, chemical reaction, or container alteration may cause the equipment to burst, and there is a risk of injury to the human body from fragments, pressurized paint or materials.
Harmful substances can cause serious injury such as inflammation and poisoning.
- **Do not loosen any parts that secure the lid while it is pressurized.**
There is a risk of injury to the human body from pressurized paint or materials. There is a risk of serious injury from inflammation or poisoning caused by harmful substances.
- **Do not use damaged hoses.**
If the hose bursts, paint or materials may spray out and enter the body through the eyes or mouth, there is a risk of serious injury such as inflammation or poisoning due to the harmful substances contained in the paint or materials.

《Warning and precautions for safe use》

 **WARNING**

Human protection



Protection from high-pressure paint

- **Do not touch the nozzle when the paint or material is under high pressure.**
There is a risk of injury to the human body from pressurized paint or materials. There is a risk of serious injury from inflammation or poisoning caused by harmful substances.
- **Always release material and air pressure before cleaning, disassembly or maintenance work.**
Do not remove or disassemble the nozzle or hose without first relieving the pressure. If paint, materials or cleaning fluids spray out and enter the body through the eyes or mouth, there is a risk of serious injury such as inflammation or poisoning due to the harmful substances contained in the paint or materials.
- **After work, make sure the paint and materials are not pressurized.**
Pressurized paints and materials can cause injury to the human body.
Harmful substances can cause serious injury such as inflammation and poisoning.

《The Need for Treatment》

If you are struck by paint or material, seek medical attention from a specialist.
In this case, you will need to tell your doctor exactly what type of paint or material you used.

《Warning and precautions for safe use》

<Pressure Release Procedure>

During inspection, nozzle removal, cleaning, or replacement, and when stopping spray operations, always follow this procedure to release the pressure.

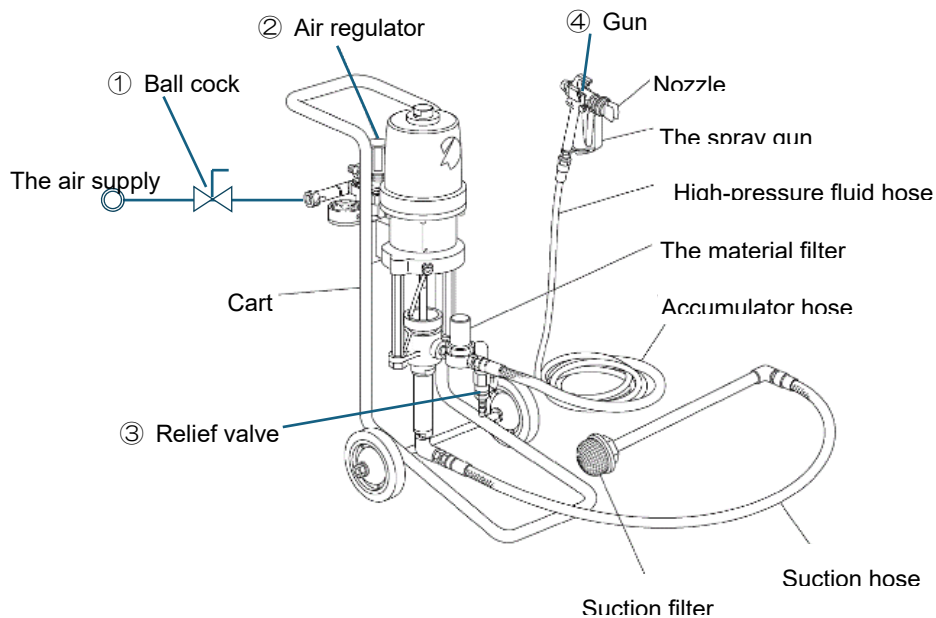

Step 1: To prevent accidental paint discharge, engage the trigger lock on the gun.

Step 2: Close '① Ball Cock' and stop the supply of compressed air. (Stop the air supply to the pump and gun.) *If using an electric pump, turn off the power.

Step 3: Turn the pressure adjustment knob of the '② Air Regulator' to the left to bring the pressure in the air pathway to zero.

Step 4: Open the material filter '③ Relief Valve' to reduce the hydraulic pressure in the paint path.

Step 5: Release the gun's trigger lock, pull the '④ trigger,' and reduce the hydraulic pressure in the paint pathway to zero.

Step 6: Make sure that the paint pressure has dropped sufficiently, then lock the gun trigger again.

(If the hydraulic pressure does not fully release even after performing the pressure release procedure)

- Wrap the chip guard mounting nut or the hose terminal connector with a cloth or similar material, and slowly and carefully loosen it to reduce the pressure and discharge the paint inside.

《Warning and precautions for safe use》

 **CAUTION**

- **Do not use this product outside its specifications.**
Using it out of specification range may result damage to the product.
- **Hoses should be hung from the ceiling or side walls and not dragged across the floor.**
It may cause damage such as scratches.
When using conductive paint, be sure to suspend the paint hose from an insulating material such as a rubber tube.
- **Check frequently for paint leaks, air leaks, and loose screw.**

● **A fire extinguisher should always be kept near the work area.**

In case of a fire, make sure to have equipment that has been regularly inspected installed at all times.

● **When disposing of this product, please dispose of it in accordance with the laws of your country.**

2

Specifications, Dimensions and System Configurations

● Dimensions

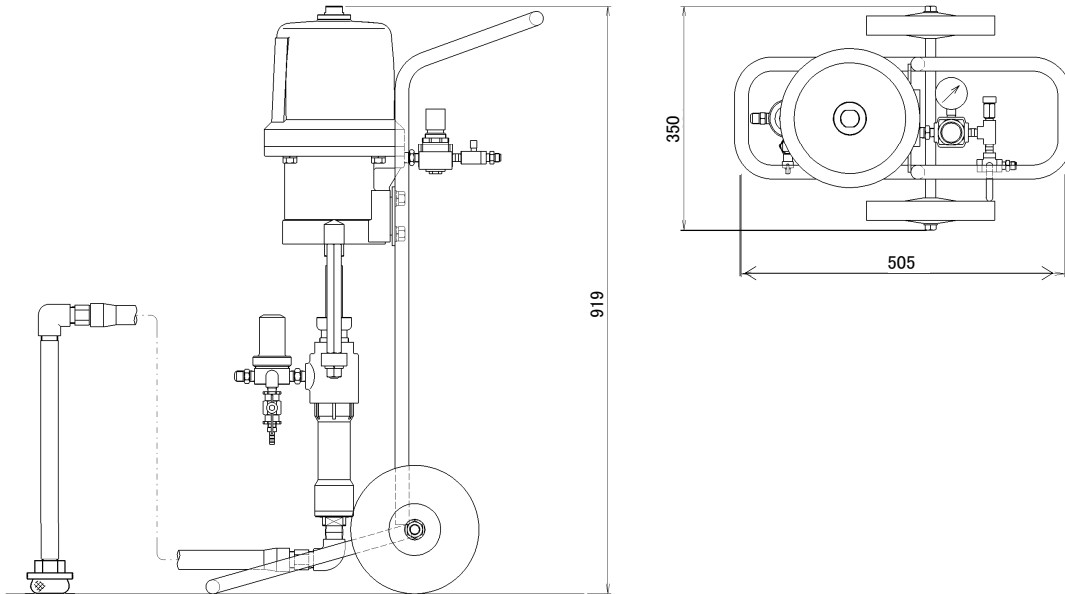

● Specifications

Model	SP1636	SP1628
Name	Light Bear	
Pressure ratio	1 : 20	1 : 30
Fluid flow	3.2L/min (Max. 10 L/min)	2.2L/min (Max. 6.8 L/min)
Maximum fluid working pressure	10Mpa (Air pressure at 0.5MPa)	15MPa (Air pressure at 0.5MPa)
Dimensions	500 ^L × 350 ^W × 900 ^H mm	
Weight	33kg	32kg
Compressor requirements	Continuous 1.5kW (2PS) Intermittent 0.75kW (1PS)	

● System Configurations

Pump	Suction filter
	Suction hose
	Air regulator
	Air pressure gauge
	Nozzle cleaner
	Material filter
	Special tool
	Accumulator hose
Airless spray gun	※
Airless nozzle	
Material hose	

The items marked with ※ do not come with the equipment as standard accessories. Please choose suitable items from our painting equipment catalog that will best suit your applications.

3

Setting Up for Operation

① General Set-up Precautions

- (1) This airless spray equipment uses compressed air for the fluid displacement pump.
Use a compressor with a capacity of 1.5kW (2PS) or larger.
- (2) Supply dry compressed air.

CAUTION

Wet compressed air, if supplied, may cause pump failure, such as valve shifting error, due to freezing or rusting. Watch water accumulation, etc. in the compressor tank.

- (3) Pressure drop occurs when a compressor is installed in a place far removed from the pump. The maximum compressed air pressure supplied to the pump is 0.5 Mpa.
Determine the capacity of compressor taking the compressor-to-pump distance into account.
- (4) Securely ground the grounding wire.
Connect a ring crimp terminal (that comes with the equipment) to the pump grounding terminal , the other clip to a Class D grounding object.

WARNING

Improper grounding may cause electric shock, fire or explosion.

- (5) When you noticed any failure symptom, take corrective actions in accordance with the “6. Tear Down Inspection and Parts Replacement” and “7. Troubleshooting”.
If your problems still exist after you did all this, don't try to do anything further but immediately contact our agency near you or Asahi Sunac directly, giving us details about the problems. Please rest assured; we'll take care of them.

② Unpacking and Connections

(Refer to “9. Component Names” for part names.)

Being 100% inspected at the factory before shipment, the airless pump is ready for operation once connections are made with a hose and gun. Upon unpacking, however, please check the contents thoroughly for any damage that may have occurred in transit and for missing parts. If you find anything wrong, please get in touch with our agency near you or us directly at Asahi Sunac.

- (1) Upon unpacking you'll find that the equipment, high-pressure hose, and spray gun are not assembled yet. You'll have to put them together in the manner as described below:
- (2) Connect a ring crimp terminal (that comes with the equipment) to the pump grounding terminal , the other clip to a Class D grounding object.

WARNING

Improper grounding may cause electrical shock, fire or explosion.

- (3) Connect the accumulator hose to the joint at the outlet of cylinder-shaped material filter.
And connect the fluid hose to the joint further down.

 **WARNING**

Ensure that the fluid hose is hooked up securely. A loosely connected hose may provide injection and splash hazards, possibly causing personal injury or accident.

- (4) Mount the spray gun at the end of high-pressure fluid hose. At this point, do not put the nozzle on, yet.

 **WARNING**

When you mount the spray gun, lock trigger. If you fail to lock the trigger, it may be pulled accidentally and personal injury may result.

- (5) Connect the air hose to the nipple at the air regulator inlet.
With this you have made all the connections that have to be made.

4

Operation

① Operation

▲ Flushing the equipment before first use

Flush the equipment before first use. Check the fluid passage for leak at the same time. If there is any leak, retighten using two (2) special spanner, putting one on the joint, the other on the base. Remove foreign materials, as well.

NOTICE

Foreign materials, such as dust, contaminants, etc., may cause the nozzle to get clogged, resulting in inconsistent spray pattern. Flush thoroughly.

Equipment Flushing Procedure

(1) Provide 3 liters of solvent (cleaning thinner).

Fill an empty can (fluid container) with solvent (cleaning thinner). Put the suction pipe into the can and check to see that the suction filter is fully immersed in the solvent.

(2) Gradually open the air regulator (turn clockwise) and supply compressed air and then start operation. Set the compressed air at about 0.1 MPa.

CAUTION

In order to prevent an air regulator from getting damage, unlock the handle of air regulator before operate.

(3) Put the tip of spray gun into solvent and pull the trigger. Solvent circulates through the system, purging air inside (which comes out in the form of bubbles).

This will clean the liquid passage through the system, hose and gun.

(4) Once passage cleaning is done, pull the suction pipe off the fluid can and run the pump idly to completely remove residual solvent within the pump. And then close the air regulator (turn counter-clockwise).

Now it's ready for operation.

▲ Starting and adjusting the pump

(5) Provide a paint fluid can.

(6) Repeat Step (1) through (3), with paint fluid.

(7) Adjust the air regulator to keep compressed air pressure at 0.2 to 0.5MPa.

The fluid pressure of:

SP1636 is 20 times the compressed air pressure,

SP1628 is 30 times the compressed air pressure.

Therefore, when the ratio is:

1:20, fluid pressure will be 4MPa ~ 10MPa,

1:30, fluid pressure will be 6MPa ~ 15MPa or more, causing the pump to stop.

! WARNING

The fluid pressure can be 20, 30 times the operating air pressure, calling for extra care when operating the pump.

(8) Put the nozzle on the spray gun.

! WARNING

Ensure that spray gun's trigger is locked. If you fail to do so, trigger could be pulled accidentally, resulting in personal injury.

(9) Check to see that there is no leak from the joint between the painting equipment and hose.

If you find leak:

Bring the pressure down, Drain the fluid,

Then, locate the point of leakage, Retighten to fix the leak.

② Shutdown and Equipment Care

(1) Check the equipment and hose for leak from joints.

1. Interruption or overnight shutdown with resumption due in 24 hours

Leave the equipment filled with fluid.

In this case, because air will be purged from the fluid passage keeping the fluid in the way as if it were stored in a paint can, the fluid in the equipment will be kept free from solidification.

2. Long-term shutdown for a period beyond 24 hours

Completely remove fluid from the equipment and keep it empty.

Any fluid paint left inside the equipment, how little it may be, will solidify.

Flush thoroughly with solvent.

CAUTION

When you use a kind of paint that precipitates rapidly or one that is of high viscosity, flush the equipment in accordance with “Equipment Flushing Procedure” on page 11 when you shutdown the equipment.

CAUTION

When you flush, keep the solvent pressure as low as possible (the minimum pressure enough for flushing).

NOTICE

For a short-term equipment shut-down with resumption due in 24 hours, leave the equipment filled with solvent until you use the equipment again. Do so each time you shutdown the equipment. It doesn't do any harm to the equipment but keeps it in a good operating condition.

- (2) Take the nozzle off the gun. Wipe the nozzle mounting surface on the gun with a solvent-soaked rag. Then clean the nozzle (you may dip it into solvent for a while for cleaning).
- (3) Set the airless nozzle in the reversed direction with the rear end facing the nozzle cleaner, then loosen the nipple letting air jet out blowing out the materials that clogged the nozzle.

WARNING

Please exercise extreme care when cleaning or replacing the nozzle. Bring the pressure down following the “Pressure Relief Procedure” and then take the nozzle off. It is quite dangerous to try to remove paint stuck in the nozzle unless the pressure is completely removed, with the trigger locked.

Follow the procedure described below to relief pressure.

<<Pressure Relief Procedure>>

- ① Lock the trigger.
- ② Shut off air supply by turning the pressure control dial counter-clockwise, bringing down the pressure all the way.
- ③ Relieve the ball cock, bring down the system pressure to zero. Unlock the trigger and pull it for double-checking.
- ④ Lock the trigger again.
- When the nozzle or hose is clogged or when it is suspected that some pressure still remains after going through the “Pressure Relief Procedure,” slowly loosen the chip guard mounting nut or the connector at hose end, gradually releasing the pressure until it is completely relieved. Then inspect the nozzle and hose.

- (4) Clean the material filter when the day's work is done.

WARNING

Before you take parts apart, always drain all paint fluid from the system and relief the pump operating pressure down to zero.

- (5) Operate the “three-way ball cock” when you have to bring down the pressure instantly, for safety reasons. However, to relieve the paint fluid pressure down to zero, open the “ball cock.”

WARNING

When you shutdown the equipment for interruption or overnight stoppage, always lock the spray gun trigger. If you fail to do so, it may be pulled accidentally, and personal injury may result.

③ Color change and additive addition precautions

- (1) When you change paint fluids, thoroughly flush the can with solvent so that no paint residue may be left unremoved. (Paint residue may cause the nozzle to get clogged.)
- (2) When you add additives, do so through the filter.
- (3) When you change paint colors, take the suction pipe out of the paint can, pull the trigger discharging all paint from the system (this way you can save solvent), then flush it with solvent repeating suction-circulation-discharge circles as many time as it takes to completely flush the fluid passage from the inlet to outlet. After this, change paint colors.

5

Maintenance

Equipment Maintenance Guidelines

- (1) When the pump V packing is worn, replace.
(Rule of thumb: Replace every six months under normal operation condition.)
- (2) When paint is solidified and accumulated in the pump, take it apart and clean.

WARNING

Before you take parts apart, always drain all paint fluid in the system and completely relieve the pump operating pressure and wrap air pressure down to zero.

- (3) Flush the spray gun by shooting solvent. In addition, you need to clean the contacting surfaces between the seat housing and nozzle by wiping with a thinner-soaked rag. When paint is solidified in the gun, take it apart and clean.

WARNING

Please exercise extreme care when cleaning or replacing the nozzle. Bring the pressure down following the “Pressure Relief Procedure” and then take the nozzle off. It is quite dangerous to try to remove paint stuck in the nozzle unless the pressure is completely removed, with the trigger locked.

- (4) Always keep the high-pressure fluid hose clean, free from paint residue and other contaminants. Remove deposited paint, if any. Always keep the hose free from mechanical shock. (e.g., don't stomp on, don't put things on, don't run over with vehicle.)

WARNING

Never use a broken hose. Check the hose throughout its length for cut, fluid leak, wear, blister, scratches, and loose fitting. Should you find anything wrong, stop using the hose right there and then, and replace.

! WARNING

Before you take parts apart, always drain all paint fluid in the system and completely relieve the pump operating pressure and wrap air pressure down to zero.

① Air Motor

When you apply grease to the cylinder interior or replace perishable parts, follow the procedure shown below. (See the exploded diagrams for the numbers referred to in the text.)

Before you take parts apart, always drain all paint fluid in the system and shutdown compressed air supply.

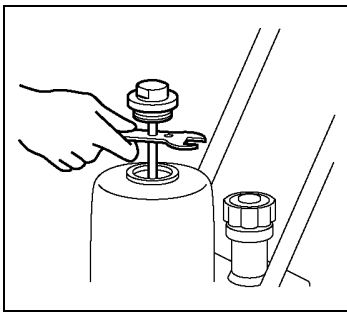

- ① Remove the cap (4) from the cylinder (1) using a special spanner. At that time, the trip rod (15) comes off with the cap. Disconnect the trip rod from the cap with a spanner. (If the trip rod is not lifted up enough to provide a room for a spanner to be manipulated, lift the cap. This will shift the valve pushing the shift rod up making access by a spanner possible.)

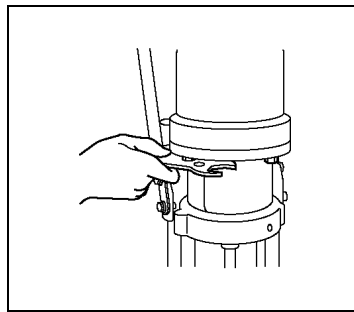

- ② Remove four bolts.

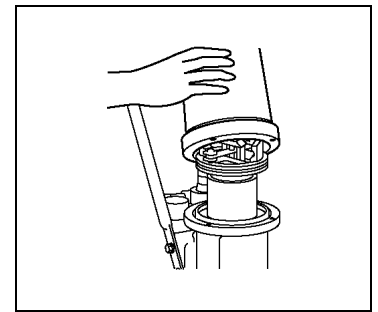

- ③ Carefully lift the cylinder and take it out from the top. The entire piston (3) and air valve (12) (16) will be exposed.

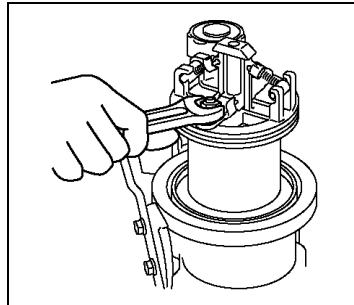

- ④ When you replace the air valves (12) and (16), do so with the toggle shuttle (5) lifted. (In this case, the spring (10) will be pointing up diagonally.)

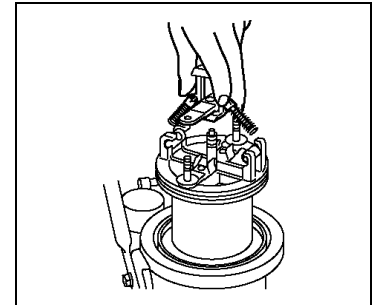

- ⑤ Remove the wire (11) and nut (18). Carefully lift the toggle shuttle (5) off.

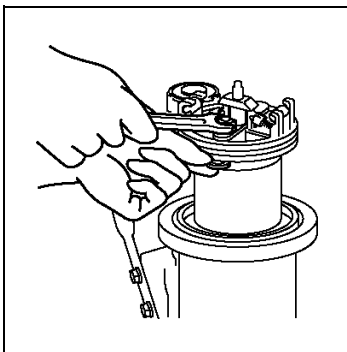

- ⑥ When you put them together again, do so in the reversed order. When reassembling, carefully mount the stay perpendicularly, to the hole. Make a 3mm clearance between air valve(12) and air hole by adjusting stay(13) then tighten top and but tom of nut(18). If you find any damage to the "O"-ring, replace.

② Material Cylinder

(See page 24 for configurations and part names.)

Shown below are the replacement procedures for the booster “V packing” at the upper end of the cylinder and the suction “V packings” at the lower end of piston rod.

Packing can be adjusted by retightening the packing retainer (2).
Service the pump setting it flat horizontally.

[Booster V Packing Replacement Procedure]

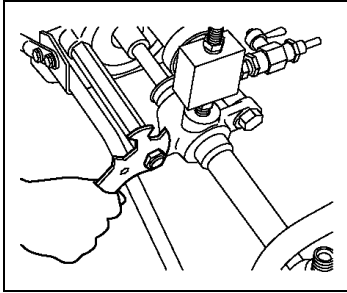

- ① Remove the accumulator hose.
Remove the nut for the stay that connects the pump housing (1).

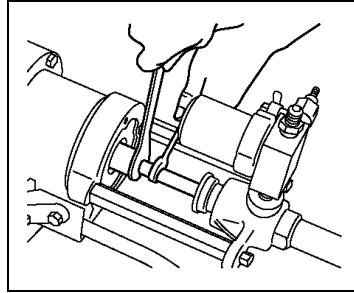

- ② Loosen the nut (19) disengaging the threaded portion of the rod and piston rod (6).
Disconnect the air motor from the material cylinder.

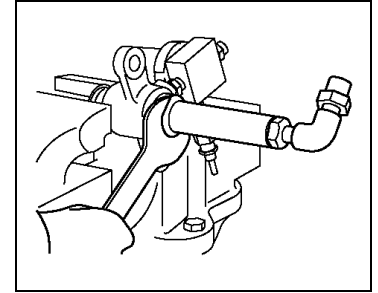

- ③ Remove the cylinder (14) from the pump housing (1).

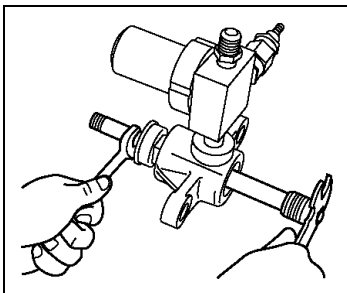

- ④ Put a spanner on the piston rod (6) and remove the screw part of the check valve (8).
Remove the check valve together with the V-packing.

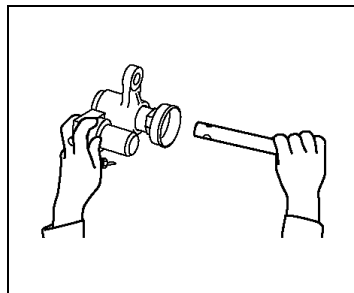

- ⑤ Loosen the packing retainer (2).
Pull off the piston rod (6).
Remove the V packings.

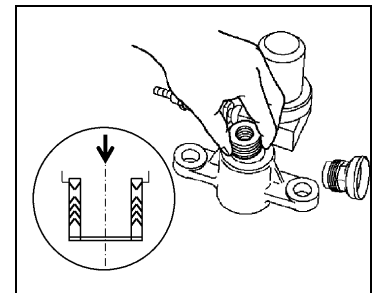

- ⑥ Put in new V packings, one by one.
(Install the packing gland and V packings with the convex side pointing up.)

Reassemble in the reverse order.

[Suction V Packing Replacement Procedure]

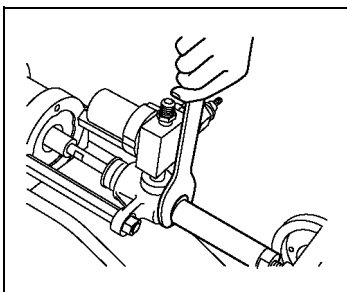

- ① Remove the cylinder (14) from the pump housing (1).

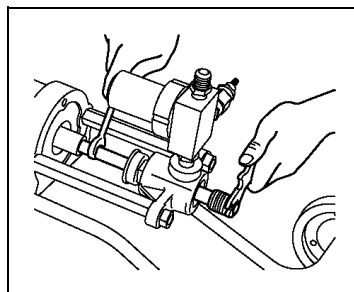

- ② Put a spanner on the piston rod (6) and remove the screw part of the check valve (8).
Remove the check valve together with the V-packing.

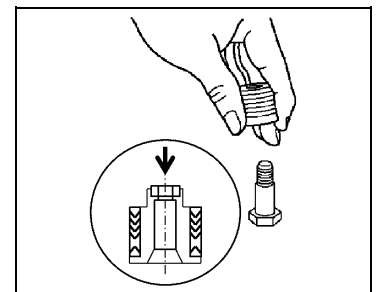

- ③ Install new V packings, one by one.
(Install the packing gland and V packings with the convex side pointing down.)

Reassemble in the reverse order.

Note: Remove the check valve, the valve ball will come out, so be careful not to lose it.

7

Troubleshooting

Symptom	Cause	Remedy
1. No fluid pressure	① Air regulator valve not opened.	① Fully open (turn clockwise).
	② Defective pressure gauge	② Replace it with a new one.
	③ Poor cleaning: Pump valve stuck due to hardened paint	③ Flush thoroughly with thinner. If hardened paint still remains after that, disassemble pump and clean.
2. Pressure does not rise to working pressure	① Air in fluid passage	① Pull spray gun trigger for air bubble purging through fluid circulation.
	② Insufficient fluid supply	② Replenish fluid.
	③ Worn V packings	③, ④ Replace V packings following V Packing Replacement Procedure.
	④ V packing installed in reversed direction	
	⑤ Clogged suction filter not sucking enough	⑤ Clean suction filter (8).
3. Pump runs, but amortizing poorly	① Insufficient compressed air supply capacity	① Replace compressor with one with larger capacity.
	② Compressed air supply hose too small in diameter	② Use larger hose in terms of diameter.
	③ Much compressed air consumed elsewhere	③ Provide a separate compressed air source for exclusive use.
	④ Air regulator not operating properly or setting pressure too low	④ Readjust.
	⑤ Insufficient fluid	⑤ Replenish fluid.
	⑥ Clogged material filter	⑥ Clean screen of material filter.
	⑦ Worn air motor valve or pump packing	⑦ Replace perishable parts with new ones following Parts Replacement Procedure.
	⑧ Nozzle of filter clogged with foreign materials	⑧ Flush and clean.
	⑨ Worn nozzle	⑨ Replace nozzle with a new one. (If worn too fast, suspect nozzle compatibility with fluid. Also, if pressure too high, nozzle service life gets shorter.)
4. Fluttering spray and tails	① ① through ⑨ per 3 above, apply	① Check ① through ⑨ per 3 above.
	② Fluid viscosity too high	② Adjust viscosity to proper level.
5. Pump does not stop when stop spraying	① No fluid	① Replenish fluid.
	② Leak from fluid passage	② Bring fluid pressure down to zero and retighten.
	③ Worn V packings	③ Replace V packings with new ones.
6. Pump fails to operate if compressed air introduced	① Seizure of rod and oiles metal	① Disassemble and clean rod and metal. Replace oil seal with new one. If damage is found to rod or metal replace.
	② Packing retainer, (2) on page 26, too tight	② Loosen packing retainer. The retighten it by hand until you can not turn it any further. Then turn it about another 15° ~ 30° using a spanner. That will be tight enough.
7. Air leak (Sound is heard when air leaks)	① Air valve is stuck in middle of stroke	① Remove cap and lift trip rod. (refer to page 18)
	② Air valve is defective	② Replace
	③ Spring is defective	③ Replace
8. Pump operates, but output low	① Clogged suction filter	① Remove and clean. If filter gets clogged all too soon, suspect incompatibility. Contact us.
	② Worn V packings affecting suction performance	② Replace packings with new ones
	③ Foreign materials between valve seat and ball	③ Remove and clean
9. Fluid flow suddenly stops while spraying	Clogged nozzle	Dip nozzle into thinner for a while to make foreign materials softer. Then blow out with compressed air from the opposite end.

NOTICE

V Packing Replacement Precautions

- (1) Install V packings in the correct direction with the convex side pointing in the right direction.
- (2) Cylinder^⑭ clearance should be such that it can be pushed in by hand.
When it's too tight, do not use plain washers^① at all or use only one washer.
If the clearance is too tight, cylinder stroke may get sticky.
If the clearance is too loose, suction failure may occur.
- (3) To mount the packing retainer^②, tighten it by hand as far as you can.
Then tighten it further with a spanner for another 15° ~ 30°.
If you tighten excessively, operational failure may occur.
If you tighten insufficiently, oil leak may occur.

Proper retightening at the end of service work helps packing to last longer.

CAUTION

When you replace the suction filter^⑧ on page 22, be sure to wear safety gloves to avoid possible injury.

● How to pull up a trip rod

Use a HEX26 spanner to loosen the cap.

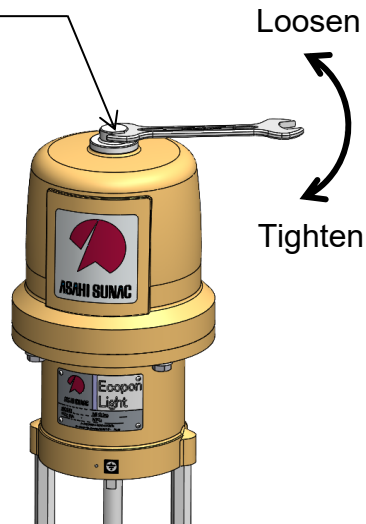

Grasp the cap with your hand and pull it straight up.

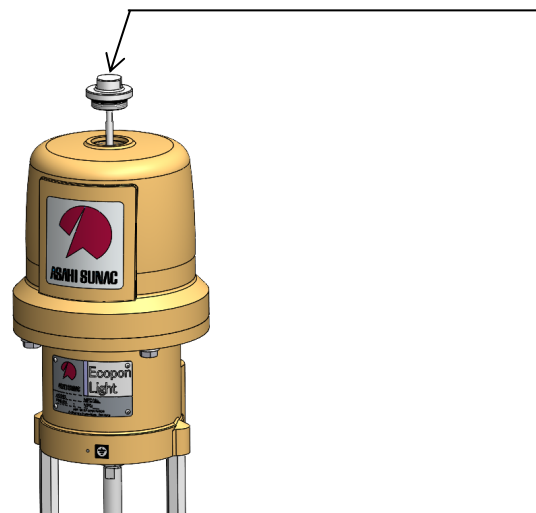
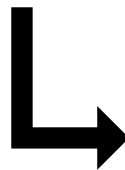

Assembly is in reverse procedure.

⚠ WARNING

Always relieve paint and air pressure before cleaning, disassembly or performing any maintenance work.

- Pressurized paint, cleaning fluid and air can cause injury to the human body.
- Harmful substances may cause serious injury such as inflammation and poisoning.

(1) Always pay attention to pressure

- Don't raise output pressure more than required.
- Always lock the trigger of your gun – each time you stop spraying for a break or interruption.
- When you found leak from joint,
Bring the pressure down,
Drain the fluid,
Locate the point of leakage,
Retighten.
- Use the lowest pressure possible, when:
Flushing the fluid circulation passage in the system,
Circulating fluid.
(Air pressure at about 0.1MPa)

(2) Check the appearance of the material hose.

- Is there any sharp bending along the line?
- Are hose fittings tight enough?
- No hose damage?
- No trace of any heavy object placed on the hose?
- Replace the concerned parts to new one if these abnormalities are detected.

(3) In switching and addition of the paints,

- When you change paint fluid, thoroughly flush the can with solvent so that no paint residue may be left unremoved. (Paint residue may cause the nozzle to get clogged.)
- Be sure to add the filtered paints.
- In color changing, draw the suction part out from the paint can and discharge all paints by opening the valve of gun or outlet side.
Next, repeat the procedures of suction (It reduces cleaning solvent consumption.), circulation and discharging and then, change the color after the paint route is completely cleaned.

(4) Method for measuring pump operation counts (Option)

- By using the optional air counter cap (0101-404), the number of pump operations can be measured using the air counter.

※For details, please contact distributor or the contact information on the back cover.

(Note) The specifications and configurations of this equipment are subject to change without prior notice due to improvements being made continuously.

9

Component Names

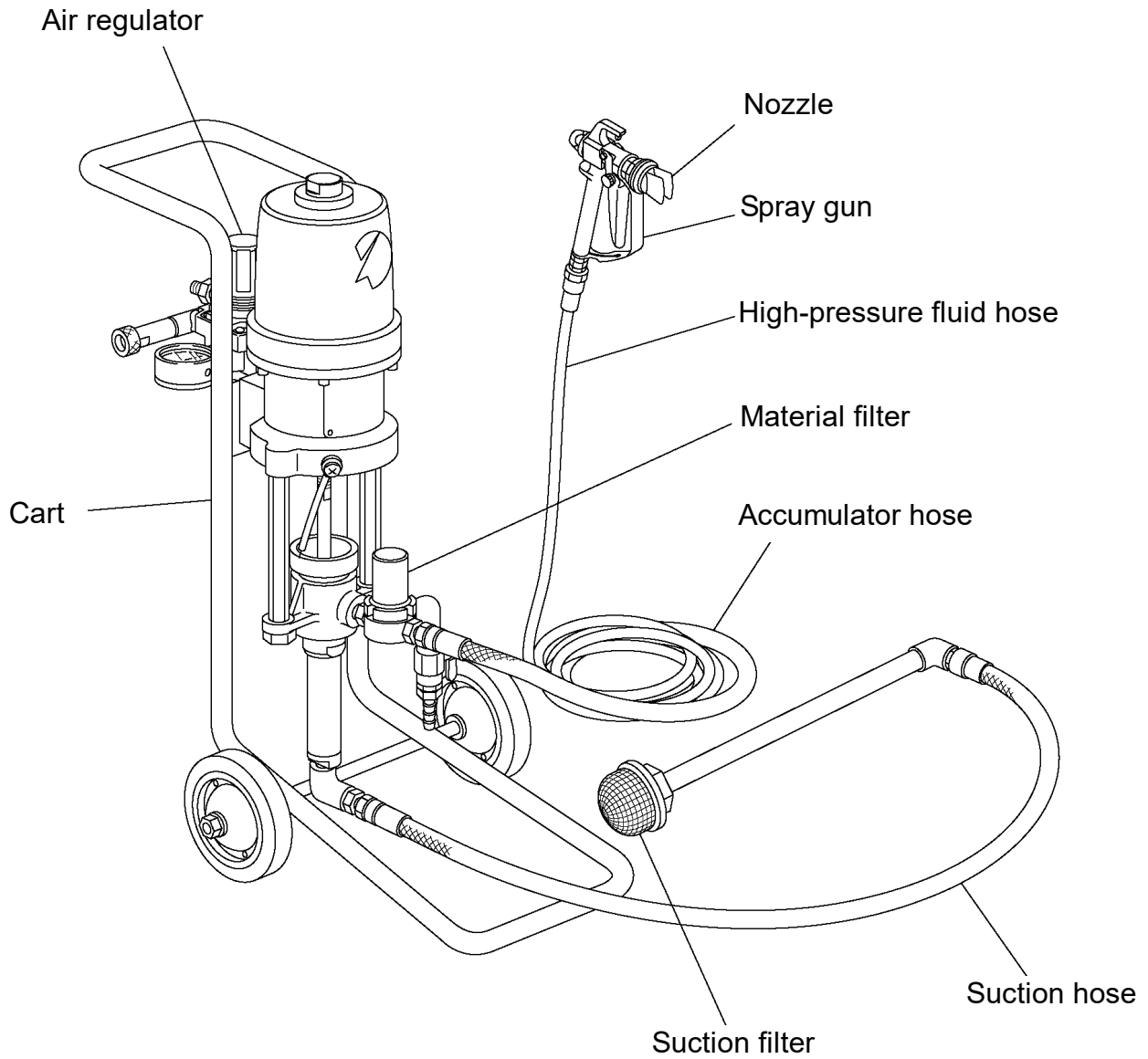

SP1628

40344-7

SP1636

40344-6

SP1628S

40378-4

SP1636S

40378-5

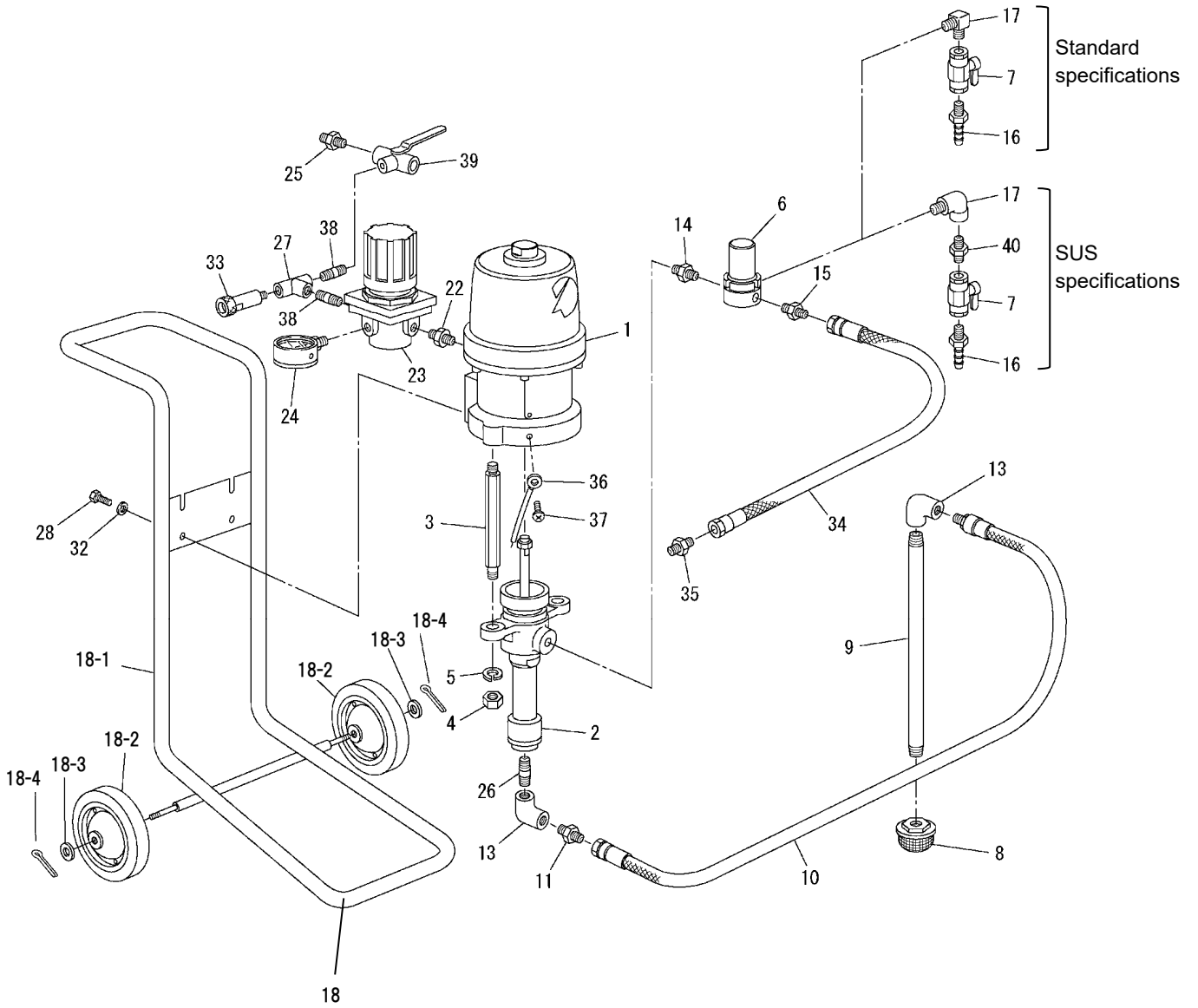

Airless Pump SP1628<40344-7>, SP1636<40344-6> Standard specifications

No.	Part No.	Part Name	Qty	Remarks
1	0102-4	Air motor	1	
2	0280-3	Material cylinder	1	SP1636
	0281-3			SP1628
3	4102-501	Stay	2	
4	15-11600	Hex. nut	2	
5	41-51600	Spring washer	2	
6	0410	Material filter	1set	
7	0902	Ball cock	1set	1/4
8	0527-046	Suction filter	1	40 mesh
9	4303-301	Suction pipe	1	
10	5605	Suction hose	1	
11	3201-049	Hose joint	1	
13	201-3006	Elbow	2	
14	287-2003	High-pressure nipple	1	
15	3201-012	Hose joint	1	
16	3203-001	Rubber hose joint	1	
17	279-2002	High-pressure elbow	1	
18	2076-2	Cart	1set	
18-1	2076-201	Cart frame	1	

No.	Part No.	Part Name	Qty	Remarks
18-2	309-0040	Caster	2	
18-3	37-11200	Plain washer	2	
18-4	49-10330	Split pin	2	
22	288-2001	High-pressure reducing nipple	1	
23	301-0025	Air regulator	1	
24	305-0003	Pressure gauge	1	
25	347-0001-1	Nipple	1	
26	242-1006	Barrel nipple	1	
27	205-3002	Tee	1	
28	01-11225	Hex. bolt	4	
32	37-11200	Plain washer	4	
33	1405	Nozzle cleaner	1set	
34	563-1020	Accumulator hose	1	
35	3202-211	Interim nipple	1	
36	40338-024	Grounding wire	1	
37	68-10406	Screw	1	
38	242-1002	Barrel nipple	2	
39	325-0009	Three-way ball cock	1	

Items marked with ※ No.18-1,18-2,18-3,18-4 are accessory of No.18 cart.

Airless Pump SP1628S<40378-4>, SP1636S<40378-5> SUS specification

No.	Part No.	Part Name	Qty	Remarks
1	0102-4	Air motor	1	
2	0290-4	Material cylinder	1	SP1636S
	0291-2			SP1628S
3	4102-501	Stay	2	
4	15-11600	Hex. nut	2	
5	41-51600	Spring washer	2	
6	0411	Material filter	1set	
7	0913	Ball cock	1set	1/4
8	0527-046	Suction filter	1set	40 mesh
9	4323-301	Suction pipe	1	
10	5616	Suction hose	1	
11	3211-049	Hose joint	1	
13	201-4006	Elbow	2	
14	287-4003	High-pressure nipple	1	
15	299-4303	Hose nipple	1	
16	3213-001	Rubber hose joint	1	
17	285-4002	High-pressure elbow	1	
18	2076-2	Cart	1set	
18-1	2076-201	Cart frame	1	

No.	Part No.	Part Name	Qty	Remarks
18-2	309-0040	Caster	2	
18-3	37-11200	Plain washer	2	
18-4	49-10330	Split pin	2	
22	288-2001	High-pressure reducing nipple	1	
23	301-0025	Air regulator	1	
24	305-0003	Pressure gauge	1	
25	347-0001-1	Nipple	1	
26	242-4006	Barrel nipple	1	
27	205-3002	Tee	1	
28	01-11225	Hex. bolt	4	
32	37-11200	Plain washer	4	
33	1405	Nozzle cleaner	1set	
34	563-2020	Accumulator hose	1	
35	3212-205	Interim nipple	1	
36	40338-024	Grounding wire	1	
37	68-10406	Screw	1	
38	242-1002	Barrel nipple	2	
39	325-0009	Three-way ball cock	1	
40	287-4002	High-pressure nipple	1	

Items marked with ※ No.18-1,18-2,18-3,18-4 are accessory of No.18 cart.

Air motor
0102-4

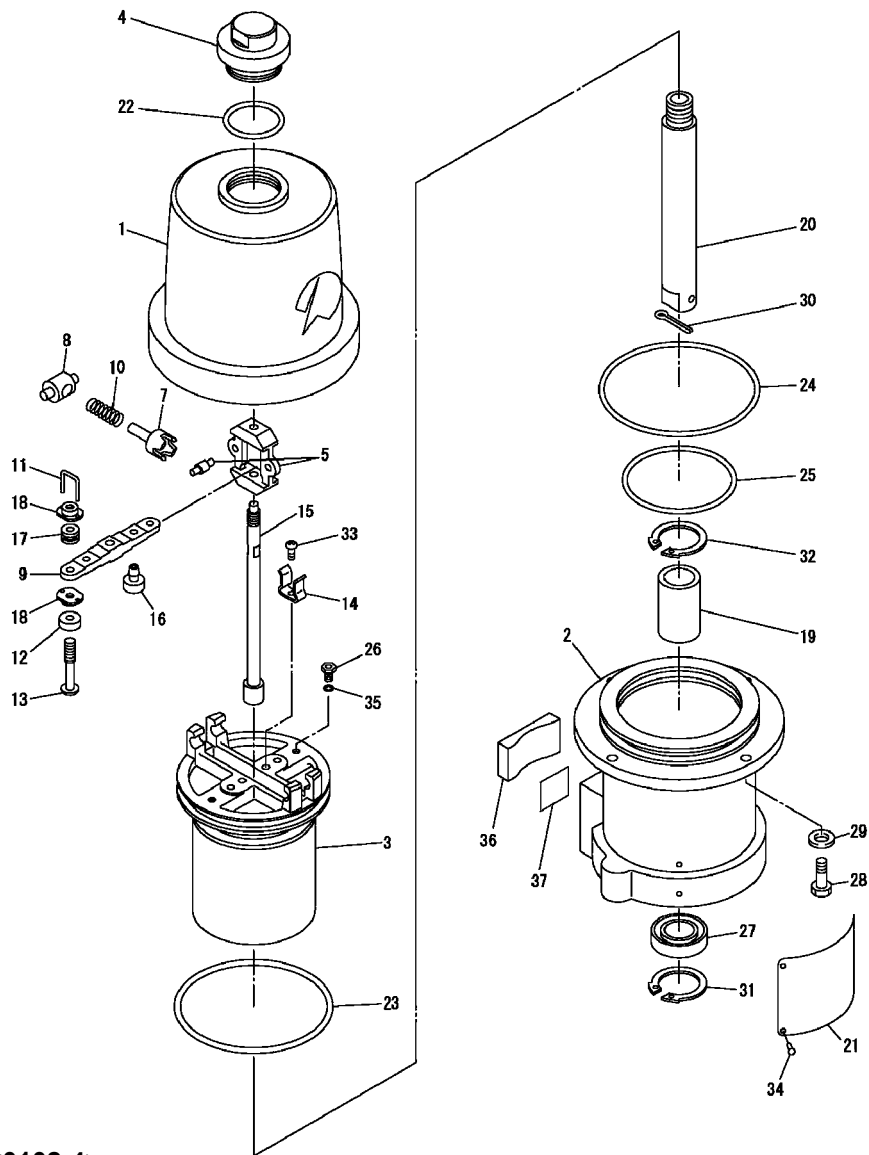

Air motor AC1610 <0102-4>

No.	Part No.	Part Name	Qty	Remarks
1	0102-701A	Cylinder	1	
2	0102-702A	Stand	1	
3	0102-703	Piston	1	
4	0101-304	Cap	1	
5	0101-005	Toggle shuttle	1	
6	Nil			
7	0102-007	Toggle arm	2	
8	0101-008	Toggle locker	2	
9	0105-009	Valve bar	1	
10	0102-110	Spring	2	
※11	0101-011	Wire	2	
※12	0101-012	Air valve	2	
13	0101-013	Stay	2	
14	0101-014	Clip	2	
15	0102-715	Trip rod	1	
※16	0101-016	Air valve	2	
※17	0101-017	Washer	2	
18	0101-118	Nut	4	
19	0101-019	Oilless metal	1	

No.	Part No.	Part Name	Qty	Remarks
20	0102-520	Rod	1	
21	0102-421	Name plate	1	
22	103-6025	O-ring	1	
※23	101-6150A	O-ring	1	
24	102-6165	O-ring	1	
※25	101-6115	O-ring	1	
26	0102-726	Bushing	2	
27	151-0001	Oil seal	1	
28	01-11240	Hex. bolt	4	
29	0C-91200	Spring washer	4	
※30	49-10432	Split pin	1	
31	56-13800	Stop ring	1	
32	56-13200	Stop ring	1	
33	68-10406	Cross recessed pan head screw	2	
34	91-40408	Parker stud	4	
35	146-7024	Gasket	2	
36	0102-039	Noise-canceling unit	1	
37	0102-046	Seat	1	

Items marked with ※ are the parts we recommend you to carry in stock.

Material cylinder

0280-3

Material cylinder

0281-3

Material cylinder

0290-4

Material cylinder

0291-2

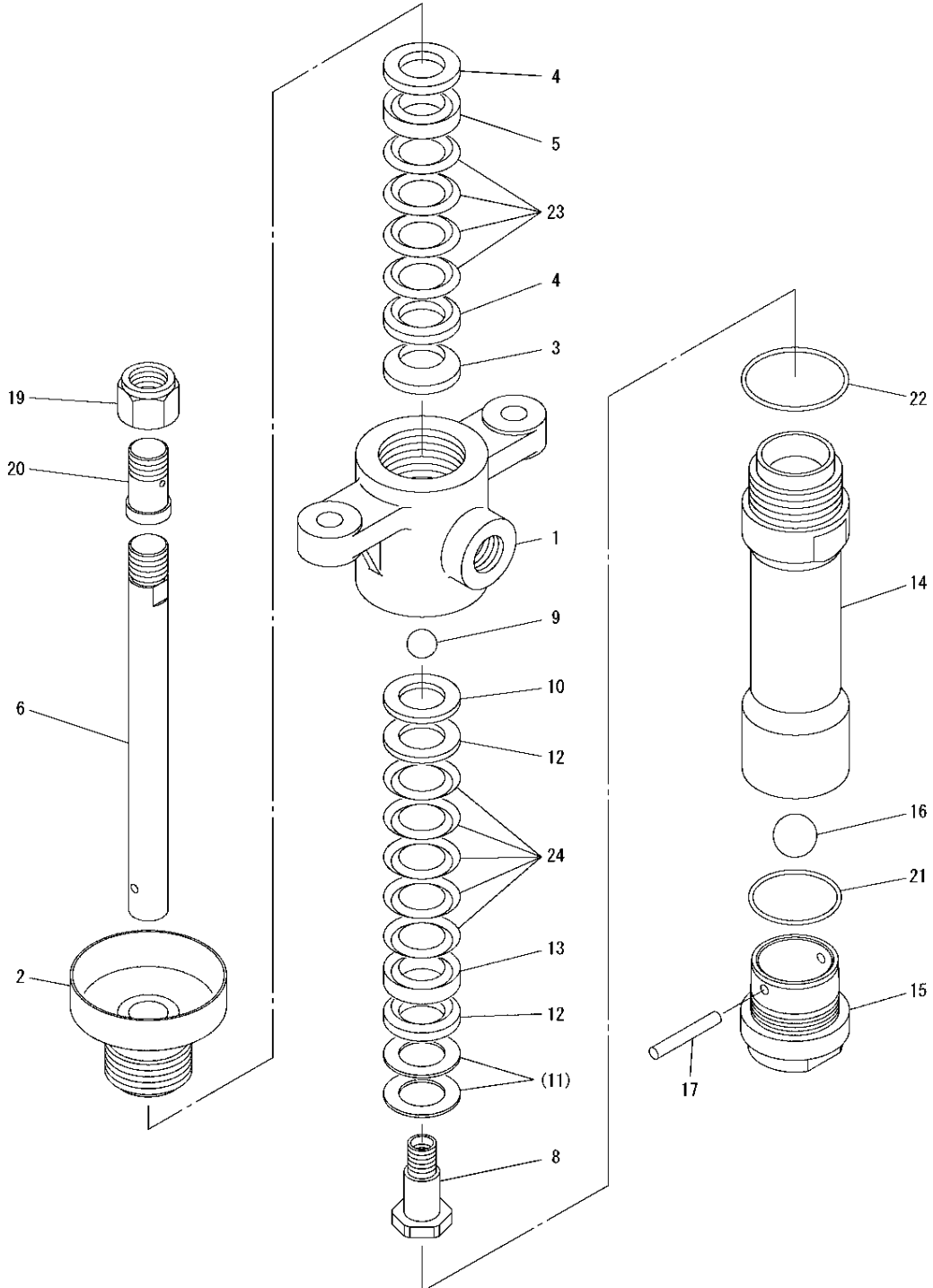

Material cylinder<0280-3(1:20)>, <0281-3(1:30)>

No.	Part No.	Part Name	Qty	Remarks
1	0280-001A	Pump housing	1	
	0280-001A			
2	0280-302	Packing retainer	1	
	0281-302			
3	0280-325	Ring spring	1	
	0280-325			
4	0280-013	Packing retainer	2	
	0281-005			
5	0280-003	Retainer	1	
	0281-007			
6	0280-106	Piston rod	1	
	0281-106			
8	0280-108	Check valve	1set	
	0281-108			
※9	0280-009	Valve ball	1	
	0210-009			
10	0280-010	Ring	1	
	0281-010			
11	0280-011	Plain washer	(2)	There are cases where this item is not used.
	0202-011			
12	0280-013	Packing retainer	2	
	0281-013			

No.	Part No.	Part Name	Qty	Remarks
13	0280-003	Retainer	1	
	0281-003			
14	0280-014	Cylinder	1	
	0281-114			
15	0280-115	Foot valve	1set	
	0280-115			
※16	0280-016	Valve ball	1	
	0280-016			
17	0280-017	Pin	1	
	0280-017			
19	0280-019	Nut	1	
	0280-019			
20	0280-020	Special joint	1	
	0280-020			
21	102-2040	O-ring	1	
	102-2040			
22	102-2045	O-ring	1	
	102-2045			
※23	V852600366	V packing	4	
	V852000366			
※24	V852600366	V packing	5	
	V851500285			

Items marked with ※ are the parts we recommend you to carry in stock.
 ※ Part number in the upper box is for 1:20 and that in the lower box is for 1:30.

SUS specification

Material cylinder<0290-4(1:20)>, <0291-2(1:30)>

No.	Part No.	Part Name	Qty	Remarks
1	0290-001	Pump housing	1	
	0290-001			
2	0290-402	Packing retainer	1	
	0291-202			
3	0280-325	Ring spring	1	
	0280-325			
4	0290-013	Packing retainer	2	
	0291-005			
5	0280-003	Retainer	1	
	0281-007			
6	0290-106	Piston rod	1	
	0291-106			
8	0290-008	Check valve	1set	
	0291-108			
※9	0290-109	Valve ball	1	
	0291-009			
10	0290-010	Ring	1	
	0291-010			
11	0290-011	Plain washer	(2)	There are cases where this item is not used.
	0222-011			
12	0290-013	Packing retainer	2	
	0291-013			

No.	Part No.	Part Name	Qty	Remarks
13	0280-003	Retainer	1	
	0281-003			
14	0290-114	Cylinder	1	
	0291-214			
15	0290-015	Foot valve	1set	
	0290-015			
※16	0290-116	Valve ball	1	
	0290-116			
17	0290-017	Pin	1	
	0290-017			
19	0290-019	Nut	1	
	0290-019			
20	0290-020	Special joint	1	
	0290-020			
21	102-2040	O-ring	1	
	102-2040			
22	102-2045	O-ring	1	
	102-2045			
※23	V852600366	V packing	4	
	V852000366			
※24	V852600366	V packing	5	
	V851500285			

Items marked with ※ are the parts we recommend you to carry in stock.
 ※ Part number in the upper box is for 1:20 and that in the lower box is for 1:30.

Material filter

0410

Material filter

0411

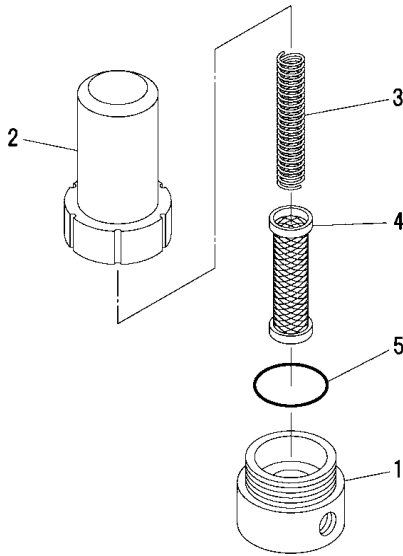

Ball cock

0902

Ball cock

0913

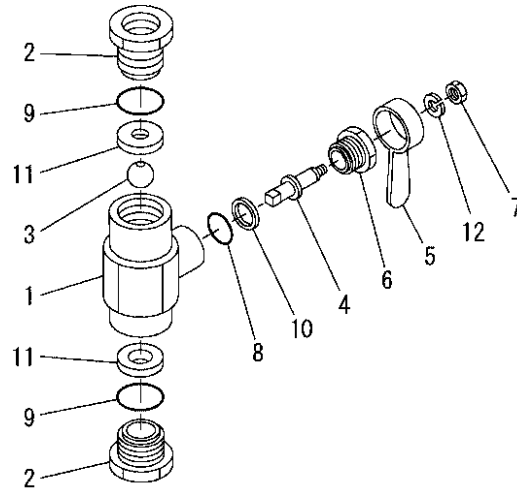

Material filter MF50E <0410>

No.	Part No.	Part Name	Qty	Remarks
1	0410-001	Filter base	1	
2	0410-002	Housing	1	
3	0402-005	Spring	1	
※4	0402-004-06	Screen	1	60mesh
※5	102-2040	O-ring	1	

Items marked with ※are the parts we recommend you to carry in stock.

Material filter MF50ES SUS specification <0411>

No.	Part No.	Part Name	Qty	Remarks
1	0411-001	Filter base	1	
2	0411-002	Housing	1	
3	0412-005	Spring	1	
※4	0412-004-06	Screen	1	60mesh
※5	102-2040	O-ring	1	

Items marked with ※are the parts we recommend you to carry in stock.

Ball cock HPC2T <0902>

No.	Part No.	Part Name	Qty	Remarks
1	0902-001	Body	1	
2	0902-002	Nipple	2	
3	0902-003	Ball	1	
4	0902-004	Shaft	1	
5	1507-107	Handle	1	
6	0902-006	Screw	1	
7	0902-007	Nut	1	
※8	103-6004	O-ring	1	
※9	103-6009	O-ring	2	
※10	144-2002	Packing	1	
※11	145-2006	Packing	2	
12	41-50400	Spring washer	1	

Items marked with ※are the parts we recommend you to carry in stock.

Ball cock HPC2TS SUS specification <0913>

No.	Part No.	Part Name	Qty	Remarks
1	0913-001	Body	1	
2	0913-002	Nipple	2	
3	0902-003	Ball	1	
4	0913-004	Shaft	1	
5	1507-107	Handle	1	
6	0913-006	Screw	1	
7	0902-007	Nut	1	
※8	103-6004	O-ring	1	
※9	103-6009	O-ring	2	
※10	144-2002	Packing	1	
※11	145-2006	Packing	2	
12	41-50400	Spring washer	1	

Items marked with ※are the parts we recommend you to carry in stock.

<Option>

Suction filter

0502

Suction filter

0521

Nozzle cleaner

1405

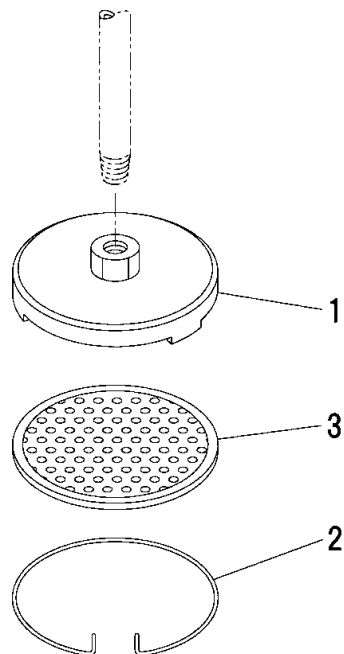
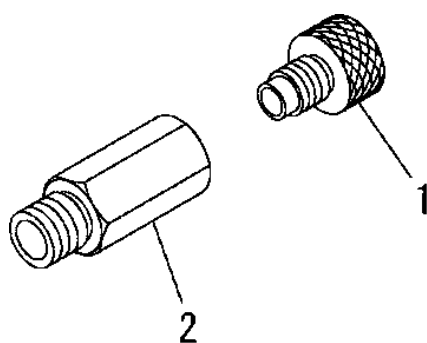

Nozzle cleaner NC <1405>

No.	Part No.	Part Name	Qty	Remarks
1	1405-001A	Nipple	1	Including Packing
2	1405-002	Socket	1	

<Option>

Suction filter SF1406

No.	Part No.	Part Name	Qty	Remarks
1	0502-001	Filter body	1	
2	0502-002	Snap	1	
※3	0502-003-04	Screen	1	40 mesh

Items marked with ※ are the parts we recommend you to carry in stock.

Suction filter SF1406S SUS specification

No.	Part No.	Part Name	Qty	Remarks
1	0502-001	Filter body	1	
2	0502-002	Snap	1	
※3	0512-003-04	Screen	1	40 mesh

Items marked with ※ are the parts we recommend you to carry in stock.

<Option>

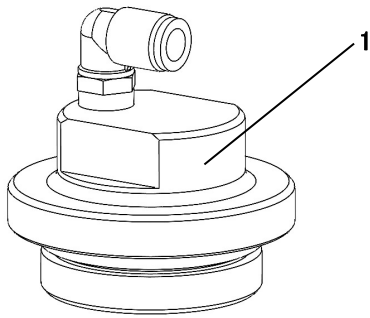

<Option>

Air counter cap 0101-404

No.	Part No.	Part name	Qty	Remarks
1	0101-404	Cap	1	Including O-ring

※When measuring operating cycles with an air counter, replace the standard cap (0101-304) on the air motor (AC1610).

10

Maintenance Log

Please use record the details that you conduct a maintenance service, such as replacement of a part, tear-down cleaning, post-failure repair, etc.

Equipment name			ECO PUMP LIGHT 20, 30 <SP1636/28(S)>		Purchase date:	
Date of service			Portion worked on	Description	Result	Who serviced
						In-house / Dealer / Asahi Sunac
						In-house / Dealer / Asahi Sunac
						In-house / Dealer / Asahi Sunac
						In-house / Dealer / Asahi Sunac
						In-house / Dealer / Asahi Sunac
						In-house / Dealer / Asahi Sunac
						In-house / Dealer / Asahi Sunac
						In-house / Dealer / Asahi Sunac
						In-house / Dealer / Asahi Sunac
						In-house / Dealer / Asahi Sunac
						In-house / Dealer / Asahi Sunac

Note: Due to continuous improvements and modifications, the configurations specified herein are subject to change without prior notice.

ASAHI SUNAC CORPORATION (the “Company”) shall provide the original purchaser (the “Purchaser”) with warranty service for a period of one (1) year from the date of purchase of the product, as follows:

- Should you find defects in design or workmanship with regard to parts, ship them back to the Company, with freight prepaid. The Company shall repair or replace the parts free of charge and reimburse the freight charges, provided that, as a result of an inspection and investigation of the parts conducted by the Company, the defects are deemed to be attributable to the factors within the Company’s responsibility.

- In the following cases, free after-sales service is not provided.
 1. Failure resulting from an inappropriate method of installing this equipment.
 2. Failure resulting from a use method not conforming to this instruction manual or mishandling.
 3. Failure resulting from insufficient maintenance management of this equipment and incorrect handling such as non-conformance to the procedures specified in this instruction manual.
 4. Failure resulting from unauthorized alteration or structure change of this equipment without the Company’s consent.
 5. Failure due to force majeure such as earthquake, disaster, flood disaster or lightning.
 6. Warranty for consumables worn or deteriorated even in the case where this equipment is used correctly.
 7. Repair after the machine has been used outside Japan, and shipping cost.
 8. In addition to the above, failure due to circumstances beyond our control.

- As for items such as parts purchased by the Company from another manufacturer, the warranty of that manufacturer shall apply.

- As for any parts deemed to be defective, the Company shall not be held liable for any expenses beyond the provision of repair or replacement parts free of charge.

- The Company shall not be held liable for any damage to the Purchaser caused by factors not attributable to the Company, such as misuse of product, etc.

-
- When a transfer of title of this equipment takes place, please ensure that this Operation and Maintenance Manual is handed over to the new owner.
 - This equipment is manufactured in compliance with the Laws and Regulations of Japan.
In the rare eventuality of this equipment being used outside Japan, compliance with the safety standards of the relevant countries is of course mandatory.
-

31th Edition: December 18, 2025

ASAHI SUNAC CORPORATION

HEAD OFFICE
5050, SHINDENBORA, ASAHIMAE-CHO,
OWARIASAHI, AICHI PREF. 488-0852, JAPAN
PHONE +81-561-52-0717 FAX +81-561-54-8847

URL : www.sunac.co.jp
E-mail : ctrd01@sunac.co.jp

Sales office



English



Chinese

31th Edition: December 18, 2025