

# Operation and Maintenance Manual

High Performance Plunger Type Airless Pump  
**ZINC PUMP**

*SP1854Z/2554Z*



This manual contains important information on warnings and cautions. Read the manual thoroughly before starting to operate the equipment, and follow the instructions. Always keep the manual handy until such time as the equipment is no longer being used. If your manual is lost or worn badly, do not hesitate to contact our agency which is closest to you, or the Asahi Sunac Corporation, directly, and ask us to send you a new one.

# Thank you for buying our product.

Thank you for buying our High Performance Plunger Type Airless Pump, Model SP1854Z/2554Z.

Please read this manual carefully before starting to operate the equipment. Please pay particular attention to major specifications, warnings and precautions, including prohibited items. Use the equipment appropriately and with care, following the instructions. We hope that by doing so you derive benefit from use of the product over a long period of time.

The pump is geared to industrial painting. It is for use only by those who are familiar with its workings and have undergone proper training; persons without such knowledge should not be allowed to operate the equipment.

Should you have any questions with regard to the manual, please give us the "Model Name" and "Serial Number" of your equipment, so that we may be able to help you with your questions. You can reach us at any of the addresses, phone numbers and fax numbers shown on the back cover.

## Contents

<b>1</b>	For Your Safety . . . . .	1
<b>2</b>	Specifications, Dimensions and System Configurations . . . . .	8
<b>3</b>	Setting Up for Operation . . . . .	9
<b>4</b>	Operation . . . . .	10
<b>5</b>	Maintenance . . . . .	13
<b>6</b>	Tear Down Inspection and Parts Replacement Procedure . . . . .	14
<b>7</b>	Troubleshooting . . . . .	16
<b>8</b>	Performance Tips . . . . .	18
<b>9</b>	Exploded Diagram and Names of Parts . . . . .	19
<b>10</b>	Maintenance Log . . . . .	26
<b>11</b>	Warranty . . . . .	27



Please carefully read this manual and get acquainted with the equipment.

Please observe the operating procedures in the manual. Failure to do so may result in **personal injury and/or damage to property**.

This manual covers only minimum safety precautions, and it does not suggest or imply that no other precautions are required. Of course, each enterprise must observe its own rules as well as the laws and regulations of the country or region in which it operates, in addition to the safety precautions in the manual.

Again, shown on the pages that follow are basic and minimum safety precautions for use of our products.

●As shown below, safety precautions are classified into three categories based on the severity of hazards involved.

 <b>WARNING</b>	Alerts a hazardous situation which may result in personal injury, with instructions on how to avoid it.
 <b>CAUTION</b>	Alerts a hazardous situation which may result in damage or breakage to equipment, with instructions on how to avoid it.
<b>NOTICE</b>	Indicates important methods and practical information.

※ A hazardous situation included in the CAUTION category could also cause a serious accident depending on how matters develop. All the precautions in the manual convey significant information that you should observe such precautions in order to ensure your own safety and prevent the equipment from failure.

## WARNING

### Equipment misuse hazard

Never use hazardous materials, such as acidic or corrosive materials, or halogenated hydrocarbon solvents with this equipment.

Should you have any questions with regard to the use of the equipment or materials to be used, please feel free to contact us.

Use of the equipment in a manner contrary to the instructions in this manual constitutes improper use, possibly causing equipment failure, injury to the operator or damage to the equipment, etc.

## **WARNING**

### **Injection Hazard**

#### **《General Safety Precautions》**

- This is a high-pressure painting equipment and an extreme care should be exercised to prevent serious personal injury.  
This pump generates very high pressure to feed paint fluid to the airless spray gun. High-pressure spray or ruptured component pieces from point-blank range can inject fluid or fragments into your body, causing skin injury from which no small amount of toxic substances might enter into the body.  
Should that happen, get a proper medical treatment by a specialist, immediately. If you don't, you may suffer from a life-long disability or you may get amputated. Fluid splashed in the eyes or on the skin can also cause serious injury.

#### **《Emergency Medical Treatment: A Must》**

**If a high-pressure fluid splashes on your skin or into the eyes, go immediately to a specialist and tell him/her exactly what type of paint fluid you were using in order to obtain proper medical treatment.**

- Don't point the gun at anyone or at any part of your body. Stay away from the trajectory of spray jet from the nozzle.
- Don't put your hand or fingers over the spray nozzle.
- Don't attempt to use the painting equipment -- until you are fully acquainted with its operation.
- Be extra vigilant when operating an air-spray painting equipment.

#### **《Spray Gun Safety Mechanisms》**

- The spray gun is equipped with safety mechanisms. Use them properly.
- Each time you use a spray gun, ensure, in advance, if all the safety mechanisms operate properly.
- Do not alter or modify or remove any part of the gun: the gun may behave unexpectedly and personal injury may result.

## **WARNING**

### **Trigger Lock**

- When not spraying, always lock the trigger safety lock in order to disable trigger. If you forget to lock the trigger, it may be pulled accidentally.

### **Chip Guard**

- When spraying, always put the chip guard on the gun. The chip guard alerts injection hazard, reducing occurrences as a result. The guard, however, cannot prevent hand or part of body from getting close to the nozzle accidentally.

### **Trigger Guard**

- Don't spray with the trigger guard removed. This guard prevents the trigger from being pulled accidentally when the gun is dropped or hit by something.

## 《Nozzle Safety Precautions》

- Don't put your hand or fingers or anything over the spray nozzle.
- Be extra careful when cleaning or replacing the nozzle.

If the nozzle gets clogged while spraying, immediately lock the trigger safety lock and relieve the fluid pressure in accordance with the “**Pressure Relief Procedure**,” and then take off the nozzle for cleaning.

It is dangerous to wipe sticky paint off the nozzle with some residual pressure still remaining or without locking the trigger safety lock.

When relieving pressure, follow the procedure below:

## 《Pressure Relief Procedure》

To reduce the risks of injury from injection, splashing fluid on the skin or in the eyes, etc., relieve the pressure following this “**Pressure Relief Procedure**” whenever you:

**Inspect the pump or gun, Remove or mount the nozzle for cleaning or replacement, Stop spraying.**

The step-by-step procedure:

- ① **Lock the trigger.**
- ② **Shut off air supply by turning the pressure control dial counter-clockwise, bringing down the pressure all the way.**
- ③ **Relieve the ball cock, bring down the system pressure to zero, unlock the trigger and pull it for double-checking.**
- ④ **Lock the trigger again.**

- **When the nozzle or hose is clogged or when it is suspected that some pressure still remains after going through the “**Pressure Relief Procedure**,” slowly loosen the chip guard mounting nut or the connector at hose end, gradually releasing the pressure until it is completely relieved. Then inspect the nozzle and hose.**

## WARNING

### Equipment Misuse Hazard

#### 《General Safety Precautions》

- Misuse, such as use of too much pressure, unauthorized component modification, improper paints or solvents, use of worn or broken part, may result in a serious accident like pump breakage, unexpected fluid injection, fluid splashed in the eyes or on the skin that possibly causes personal injury, or even fire or explosion.
- Don't alter or modify pump parts without our authorization or approval, for such a change may result in equipment failure or malfunction.
- Inspect the whole system periodically. Repair or replace parts as required.
- When conducting spray operation, always wear eye protection, protective clothing, and breathing protection recommended by the paint/solvent manufacturer.  
Depending on the kind of pint fluid used and the ventilation performance, additional personal protective equipment may be required. Please check it out with the paint/solvent manufacturer.

#### 《Equipment Interior Pressure》

- Confirm the maximum fluid working pressure and maximum air input pressure of the pump.  
Be careful not to exceed these maximum pressures when operating the pump.  
Also, make sure that all component parts used for the equipment, such as hoses, connectors, swivels, are compatible with the maximum pressures.  
Should you find them not, set the pump at a pressure that does not exceed the lowest maximum operating pressure of all parts and accessories used with the equipment.
- Each time you use the equipment, retighten all the joints before use.

#### 《Paint/Solvent Compatibility》

Check the compatibility of the paint and solvent with the “material of the pump parts they come into contact with” against the parts material specifications provided by the pump manufacturer -- before you introduce the fluid (paint/solvent) into the pump.

#### 《Hose Safety Precautions》

- High-pressure fluid in the hose can be very dangerous: it could cause injury to the operator or damage to the equipment, spewing out of cracks, damage, wear in the hose, triggered by misuse or spontaneously.
- Please handle hose carefully. To move a hose from one place to another, don't pull, but carry. Don't use paint or solvent that is not compatible with the interior and exterior materials of the hose.

## WARNING

- Check the hose for bending or squeezing, for if there is it may cause a local Concentration of pressure, causing possible fluid leak.
- Don't leave hose in an environment where temperature may go up to 80°C or higher or where it may go down to - 40°C or lower.
- Securely retighten hose connectors and joints before use.
- Never use a broken hose. Check the hose throughout its length for cut, fluid leak, wear, blister, scratches, and loose fittings. Should you find anything wrong, stop using the hose right there and then, and replace.
- When you fluid find leak, take no stopgap measures, such as covering the leak hole by hand or adhesive tape. Such measures will only increase potential hazards.
- Don't try to fix fluid leak with a repaired joint.
- When you find fluid leak, replace the hose with a new one or contact our authorized repair shop. Use a hose that is compatible with our standard specifications. A hose shorter than 20 meters is likely to have an excessive pressure build-up.
- Our fluid hose standard specifications ensure a sufficient hose durability in an normal operating environment. However, tension is applied to a hose for many hours, it deteriorates in a relatively short time. When tension is applied frequently, it may not last longer than half a year. Under normal operating conditions, replacement in a year would be recommended.

### 《Moving Parts Hazard》

- There is an air-motor piston rod in the air-motor cap. The piston rod moves up and down as air is supplied to the air-motor. When operating the pump, be sure to put the air-motor cap on so that your fingers may not be struck or caught in a pinch or shear point by the moving part, and that your eardrum may not get injured by the deafening exhaust sound.
- There is a step at the piston rod connecting nut in between the air-motor and material cylinder, which moves up and down as the pump operates. So don't touch it when the pump is operating. If you do so, you may get your fingers caught in a pinch point by the packing retainer.
- When checking or servicing the pump and component parts, bring the pressure down in advance in accordance with the “**Pressure Relief Procedure**” on page 3 in order to prevent the pump from behaving unexpectedly.
- With the pump running, don't leave the painting equipment unattended.  
Each time you stop spraying for a break or at the end of shift, shut off the air supply.
- Keep people away for the pump, children and adults who are not familiar with the airless painting operation.

## **WARNING**

### **Fire and Explosion Hazard**

#### **《Source of Fire》**

As liquid flows through the pump and hose, static electricity is generated.

If each component of the painting equipment is not properly grounded, sparks may occur due to static electricity. When there are vaporized solvent, sprayed paint particles, floating dust and other flammables in the atmosphere near the painting equipment, these sparks can cause fire or explosion, possibly causing serious injury to the operator and damage to the equipment.

- Provide fresh air ventilation in the spray area.
- Keep the spray area free of open flames, pilot lights, and other flammables.
- When using a pole gun, stay clear of electric wires.
- Ensure that equipment and conductive painting objects in the work area are properly grounded. Take no chances: when these things are not properly grounded, fire or explosion can occur triggered by electrostatic spark.
- If you feel any electric shock while using the painting equipment, stop spraying immediately and check the grounding of each component of the equipment.  
Do not use the equipment until you identify and correct the problem.
- Keep a powerful fire extinguisher in the work area.

#### **《Grounding》**

To prevent hazards associated with static electricity, ground all the pumps, painting objects, painting equipment and components that are used in the area. If they are not properly grounded, ground properly, by all means, in accordance with the grounding procedure set forth by “Electrical Equipment Technical Standard (Class D grounding or equivalent).”

The grounding procedure for each of the painting system components is as follows:

##### **Grounding Pump**

- Connect a ring crimp terminal (that comes with equipment) to the pump grounding terminal , the other clip to a Class D grounding object.

##### **Grounding Compressor**

- Arrange grounding in accordance with the compressor manufacturer's instructions.

##### **Grounding Hose**

- To ensure the grounding of a whole system, be sure to ground the hose. Especially when an extension hose is used, ensure that it is ground properly.
- Once every week, inspect the hose in use for electrical resistance.

Class D grounding, our standard grounding, requires the resistance value to be 100Ω or lower. When the hose does not have a maximum resistance label on it, please check it out with the agency from whom you bought the hose or the hose manufacturer directly.

Measure the electrical resistance of hose by connecting an ohmmeter to an appropriate location on the hose. If the resistance measured exceeds the maximum value allowed, replace the hose with a new one. Improper grounding of a hose puts the whole system in peril.

## WARNING

### **Grounding Spray Gun**

A spray gun that is securely connected to the properly grounded hose and pump is considered to be grounded properly.

### **Grounding Painting Object**

A contaminated hanger or grounding clip do not ensure proper grounding of a painting object. Keep the hanger and clip clean to maintain proper grounding.

### **Grounding Fluid Container**

When your fluid container is made of conductive metal, you can place it on the grounded floor or table. When it is made of something else, you cannot.

### **Grounding Cleaning Solvent Can**

When the cleaning solvent is made of conductive metal, you can place it on the grounded floor or table.

Don't place it on a non-conductive sheet, such as a sheet of paper or corrugated fiberboard.

When you clean the pump or relieve the pressure, hold a metal part of the gun firmly to the side of a grounded metal container and then pull the trigger.

## 《Cleaning Safety Precautions》

Before you get down to cleaning, ensure that the whole painting system and cleaning can are properly grounded. (see "Grounding Cleaning Solvent Can.")

- When cleaning the system, take off the nozzle in accordance with the procedure set forth in the <<Nozzle Safety Precautions>> (on page 3), and bring the pressure down to a minimum level (that is required for flushing with solvent).
- To prevent electrostatic spark, hold a metal part of the gun firmly to the side of a grounded cleaning solvent can (made of metal), and trigger the gun for flushing.

## 《Solvent Safety Precautions》

Halogenated hydrocarbon solvent may explode when it comes into contact with the aluminum or plated portion of pressure vessel (pump, heater, filter, valve, gun, etc.), possibly causing fatal or serious injury.

**Do not use halogenated hydrocarbon solvent.**

### 《Typical halogenated hydrocarbon solvents》

<b>Chlorines</b>	Trichloroethylene, Tetrachloroethylene, Ethylene chloride
<b>Bromines</b>	n-Propyl Bromide
<b>Carbon-fluorines</b>	HCFC-225, HFC-43-10mee, HFE-449s1(HFE-7100)

(Shown above are typical examples and there are, of course, other kinds of halogenated hydrocarbon solvents in the marketplace.)

Please check with your paint vendors or manufactures for further details.)

## WARNING

### **Spray-mist-filled atmosphere may cause respiration difficulty and/or intoxication.**

- **Do not spray in an environment where ventilation is poor, such as indoors, in tunnel, inside the tank, etc. When you spray, exercise care so that the operator, people and livestock near by may not be affected.**

### ● Dimensions

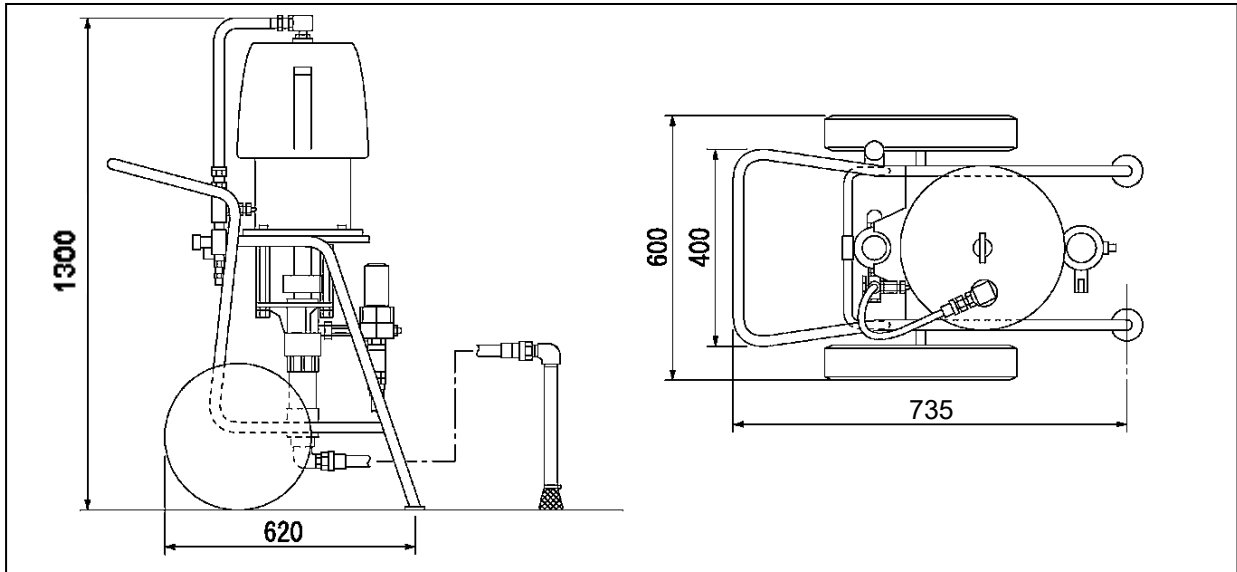

### ● Specifications

Model	SP1854Z	SP2554Z
Pressure ratio	1 : 20	1 : 45
Fluid flow	6L/min (Max.30L/min)	6L/min (Max.30L/min)
Dimensions (mm)	735L×600W×1300H	735L×600W×1300H
Weight	83kg	93kg
Compressor requirements	Continuous 6HP Intermittent 3HP	Continuous 7.5HP Intermittent 5HP

### ● System Configurations

Pump	Suction filter Suction hose Air regulator Air pressure gauge Material filter Accumulator hose (Optional item) Duster gun (Optional item) Special tool
Airless spray gun	※
Airless nozzle	※
Material hose	※

Items marked with ※ do not come with the equipment as standard accessories.

Please choose suitable items from our painting equipment catalog that will best suit your applications.

# 3

## Setting Up for Operation

### ① General Set-up Precautions

- (1) This airless spray equipment uses compressed air for the fluid displacement pump.  
Use a compressor with a capacity of 5HP or larger.
- (2) Supply dry compressed air.

### CAUTION

**Wet compressed air, if supplied, may cause pump failure, such as valve shifting error, due to freezing or rusting. Watch water accumulation, etc. in the compressor tank.**

- (3) Pressure drop occurs when a compressor is installed in a place far removed from the pump. The maximum compressed air pressure supplied to the pump is 0.5  
Use a 3/4B hose or larger.
- (4) Securely ground the grounding wire. Connect a ring crimp terminal (that comes with the equipment) to the pump grounding terminal(⊕), the other clip to a Class D grounding object.

### WARNING

**Improper grounding may cause electric shock, fire or explosion.**

- (5) When you noticed any symptom of failure, take corrective actions in accordance with the “Tear Down Inspection and Parts Replacement” (pages 14 and 15) and “Troubleshooting” (pages 16 and 17).  
If your problems still exist after you did all this, don't try to do anything further but immediately contact our agency near you or Asahi Sunac directly, giving us details about the problems.  
Please rest assured; we'll take care of them.

### ② Unpacking and Connections (See pages 19 through 25 for part names.)

Being 100% inspected at the factory before shipment, the airless pump is ready for operation once connections are made with a hose and gun. Upon unpacking, however, please check the contents thoroughly for any damage that may have occurred in transit and for missing parts. If you find anything wrong, please get in touch with our agency near you or us directly at Asahi Sunac.

- (1) Upon unpacking you'll find that the equipment, high-pressure hose, and spray gun are not assembled yet. You'll have to put them together in the manner as described below:
- (2) Connect a ring crimp terminal (that comes with the equipment) to the pump grounding terminal(⊕), the other clip to a Class D grounding object.

### WARNING

**Improper grounding may cause electric shock, fire or explosion.**

- (3) Connect the accumulator hose to the joint at the outlet of cylinder-shaped material filter.  
And connect the fluid hose to the joint further down.

### WARNING

**Ensure that the fluid hose is hooked up securely. A loosely connected hose may provide injection and splash hazards, possibly causing personal injury or accident.**

- (4) Mount the spray gun at the end of high-pressure fluid hose. At this point, do not put the nozzle on yet.

### WARNING

**When you mount the spray gun, lock trigger. If you fail to lock the trigger, it may be pulled accidentally personal injury may result.**

- (5) Connect the air hose to the nipple at the air regulator inlet.  
With this you have made all the connections that have to be made.

# 4

## Operation

### ① Operation

#### ▲ Flushing the equipment before first use

Flush the equipment before first use. Check the fluid passage for leak at the same time. If there is any leak, retighten using two (2) special spanner, putting one on the joint, the other on the base.

Remove foreign materials, as well.

### NOTICE

**Foreign materials, such as dust, contaminants, etc., may cause the nozzle to get clogged, resulting in inconsistent spray pattern. Flush thoroughly.**

Equipment Flushing Procedure

- (1) Provide 10 liters of solvent (cleaning thinner).

Fill an empty can (fluid container) with solvent (cleaning thinner). Put the suction pipe into the can and ensure that the suction filter is fully immersed in the solvent.

- (2) Gradually open the air regulator (turn clockwise) and supply compressed air and then start operation. Set the compressed air at about 0.1 MPa.

### ⚠ CAUTION

**In order to prevent an air regulator from getting damage, unlock the handle of air regulator before operate.**

- (3) Put the tip of spray gun into solvent and pull the trigger. Solvent circulates through the system, purging air inside (which comes out in the form of bubbles).

This will clean the liquid passage through the system, hose and gun.

- (4) Once passage cleaning is done, pull the suction pipe off the fluid can and run the pump idly to completely remove residual solvent within the pump. And then close the air regulator (turn counter-clockwise).

Now it's ready for operation.

#### ▲ Starting and adjusting the pump

- (5) Provide a paint fluid can.

- (6) Repeat Step (1) through (3), with paint fluid.

- (7) Adjust the air regulator to keep compressed air pressure at 0.2 to 0.5MPa.

The fluid pressure of;

SP1854Z (with ratio of 1: 20) is 20 times the compressed air pressure,

SP2554Z (with ratio of 1: 45) is 45 times the compressed air pressure.

Therefore, when the ratio is:

1:20, fluid pressure will be 4MPa~10MPa,

1:45, fluid pressure will be 9MPa~22.5MPa or more, causing the pump to stop.

### ⚠ WARNING

**Because the operating air-to-fluid ratio is 1:10, 1:20, or 1:30, fluid pressure gets very high: operate the pump very carefully.**

- (8) Put the nozzle on the spray gun.

### ⚠ WARNING

**Ensure that spray gun's trigger is locked. If you fail to do so, trigger could be pulled accidentally, resulting in personal injury.**

- (9) Check to see that there is no leak from the painting equipment or the joint between the painting equipment and hose.  
If you find leak:  
Bring the pressure down, Drain the fluid,  
Then, locate the point of leakage, Retighten to fix the leak.

## ② Shutdown and Equipment Care

- (1) Check the equipment and hose for leak from joints.
1. Interruption or overnight shutdown with resumption due in 24 hours  
Leave the equipment filled with fluid.  
In this case, because air will be purged from the fluid passage keeping the fluid in the way as if it were stored in a paint can, the fluid in the equipment will be kept free from solidification.
  2. Long-term shutdown for a period beyond 24 hours

### **WARNING**

**When you use a kind of paint that precipitates rapidly or one that is of high viscosity, flush the equipment in accordance with “Equipment Flushing Procedure” on page 10 when you shutdown the equipment.**

Completely remove fluid from the equipment and keep it empty.  
Any fluid paint left inside the equipment, how little it may be, will solidify.  
Flush thoroughly with solvent.

### **CAUTION**

**When you flush, keep the solvent pressure as low as possible (the minimum pressure enough for flushing).**

### **NOTICE**

**For a short-term equipment shut-down with resumption due in 24 hours, leave the equipment filled with solvent until you use the equipment again. Do so each time you shutdown the equipment. It doesn't do any harm to the equipment but keeps it in a good operating condition.**

- (2) Take the nozzle off the gun. Wipe the nozzle mounting surface on the gun with a solvent-soaked rag. Then clean the nozzle (you may dip it into solvent for a while for cleaning).

### **WARNING**

**Please exercise extreme care when cleaning or replacing the nozzle. Bring the pressure down following the “Pressure Relief Procedure” and then take the nozzle off. It is quite dangerous to try to remove paint stuck in the nozzle unless the pressure is completely removed, with the trigger locked.**

Follow the procedure described below to relief pressure.

**<<Pressure Relief Procedure>>**

- ① Lock the trigger.
  - ② Shut off air supply by turning the pressure control dial counter-clockwise, bringing down the pressure all the way.
  - ③ Relieve the ball cock, bring down the system pressure to zero.  
Unlock the trigger and pull it for double-checking.
  - ④ Lock the trigger again.
- When the nozzle or hose is clogged or when it is suspected that some pressure still remains after going through the "Pressure Relief Procedure," slowly loosen the chip guard mounting nut or the connector at hose end, gradually releasing the pressure until it is completely relieved. Then inspect the nozzle and hose.

(3) Clean the material filter when the day's work is done.



**WARNING**

**Before you take parts apart, always drain all paint fluid from the system and relief the pump operating pressure down to zero.**



**WARNING**

**When you shutdown the equipment for interruption or overnight stoppage, always lock the spray gun trigger. If you fail to do so, it may be pulled accidentally, and personal injury may result.**

③ **Color change and additive addition precautions**

- When you change paint fluids, thoroughly flush the can with solvent so that no paint residue may be left unremoved. (Paint residue may cause the nozzle to get clogged.)
- When you add additives, do so through the filter.
- When you change paint colors, take the suction pipe out of the paint can, pull the trigger discharging all paint from the system (this way you can save solvent), then flush it with solvent repeating suction-circulation-discharge circles as many times as it takes to completely flush the fluid passage from the inlet to outlet. After this, change paint colors.

# 5

## Maintenance

### Equipment Maintenance Guidelines

- (1) When the pump V-packing is worn, replace.  
(Rule of thumb: Replace every six months under normal operation condition.)
- (2) When paint is solidified and accumulated in the pump, take it apart and clean.

### **WARNING**

**Before you take parts apart, always drain all paint fluid in the system and completely relieve the pump operating pressure and wrap air pressure down to zero.**

- (3) Flush the spray gun by shooting solvent. In addition, you need to clean the contacting surfaces between the seat housing and nozzle by wiping with a thinner-soaked rag. When paint is solidified in the gun, take it apart and clean.

### **WARNING**

**Please exercise extreme care when cleaning or replacing the nozzle. Bring the pressure down following the “Pressure Relief Procedure” and then take the nozzle off. It is quite dangerous to try to remove paint stuck in the nozzle unless the pressure is completely removed, with the trigger locked.**

- (4) Always keep the high-pressure fluid hose clean, free from paint residue and other contaminants. Remove deposited paint, if any. Always keep the hose free from mechanical shock. (e.g., don't stomp on, don't put things on, don't run over with vehicle.)

### **WARNING**

**Never use a broken hose. Check the hose throughout its length for cut, fluid leak, wear, blister, scratches, and loose fitting. When you find anything wrong, stop using the hose right there and then, and replace.**

# 6

## Tear Down Inspection and Parts Replacement

### ⚠ WARNING

Before you take parts apart, always drain all paint fluid in the system and completely relieve the pump operating pressure and wrap air pressure down to zero.

#### ① Air Motor

※ For the index number in parentheses ( ), see page 22 to 23.

When you apply grease to the cylinder interior or replace perishable parts, follow the procedure shown below. (See the exploded diagram for the index number referred to in the following instructions.)

Before you take parts apart, always drain all paint fluid in the system and shutdown compressed air supply.

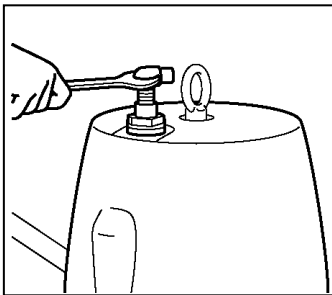

- ① Remove the air hose joint and the nipple (28) mounted on the cap (4), then remove the cap (4) itself. Now you can replenish oil in the valve.

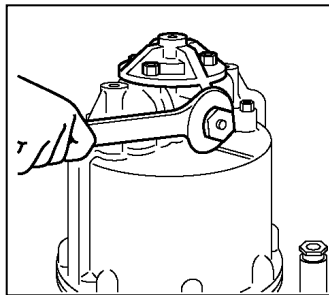

- ② Loosen the spring housing (16) with a spanner, Unscrew the four hexagon socket head cap screws in the pusher holder (9), Lift the pusher holder (9) up, and  
Remove the roller (19), pin (20) and other parts.  
If you find wear on the roller (19) and pin (20), replace them with new ones.

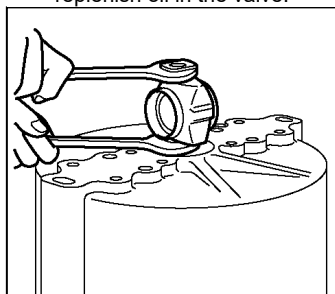
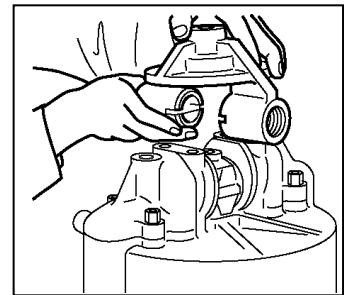

- ③ Remove the hexagon socket head cap screws from the two valve bodies (10), Remove the lock nut (24) with a spanner, putting it on the spool (23), and Remove the cam (12).

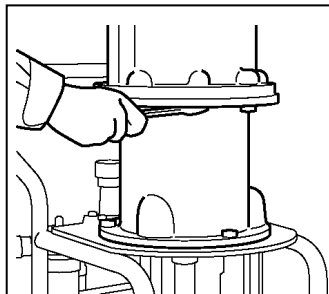

- ④ Remove mounting bolts that put the cylinder (1) and stand (2) together,  
Lift the cylinder (1) up, and  
The piston (3) will be exposed.

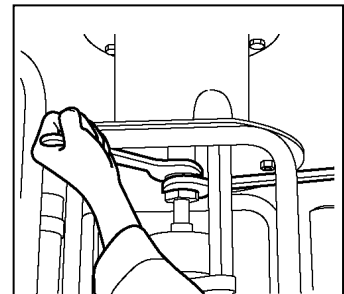

- ⑤ Inspect the "O" ring (Cosmo Bear(39), Super Bear(37)) on the piston (3).  
If you find damage or wear, replace the "O" ring with a new one.  
Clean the cylinder (1) interior and then apply grease.

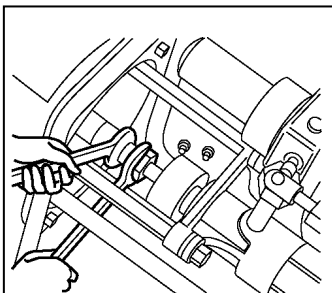

- ⑥ Remove the nut disconnecting the air motor and material cylinder.  
Lift the piston (3) up.

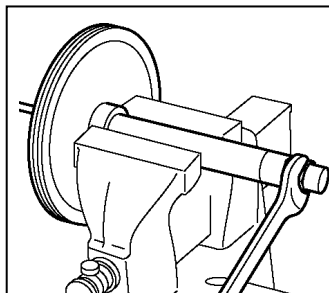

- ⑦ Disconnect the piston (3), rod (25) and adaptor (8) from one another, and  
Pull out the rod (25) and spring (27).

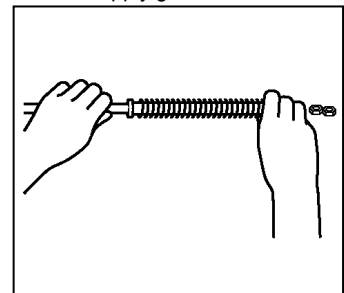

- ⑧ Inspect the spring (27).  
When valve-shifting response is slow due to spring fatigue, replace the spring (27) with a new one.  
Reassemble in the reverse order.

## ② Packing Replacement

※ For the index number in parentheses ( ), see page 24.

Shown below are the replacement procedures for the booster V-packing (23) at the upper end of the piston and the suction V-packing (23) at the lower end of the piston..

### Suction V Packing Replacement Procedure

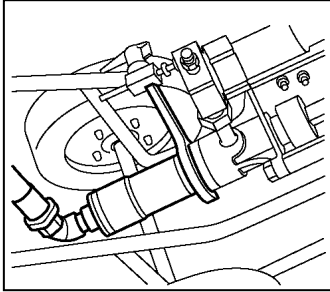

- ① Set the airless pump flat horizontally, and Remove the cylinder (14) from the pump housing (1) using a special spanner.

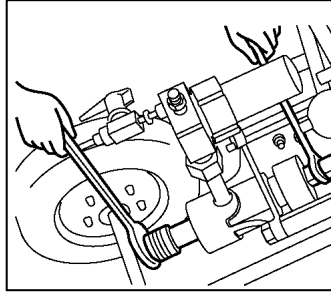

- ② Put spanners on the check valve (8) and piston rod (6), and Remove the check valve (8). Check the packing retainer (5) for wear or damage on the sliding surface, Replace it with a new one, if you find wear or damage, and Replace the V-packings (23) with a new ones.

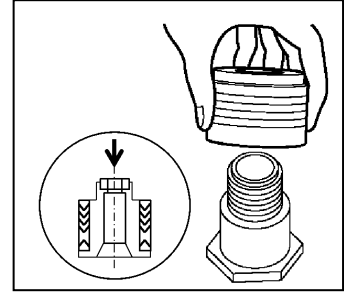

- ③ When mounting, be careful so that the direction in which the packing retainer (4) and new V-packings (23) each is installed is correct – if you install them in a wrong manner, they just don't work the way they should. Reassemble in the reverse order.

### Booster V Packing Replacement Procedure

Packing can be adjusted by retightening the packing retainer (2). To service set the pump flat horizontally.

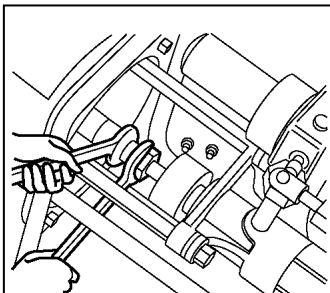

- ① Remove the nut, disconnecting the air motor and material cylinder. Remove the stay mounting nut, leaving the material cylinder alone.

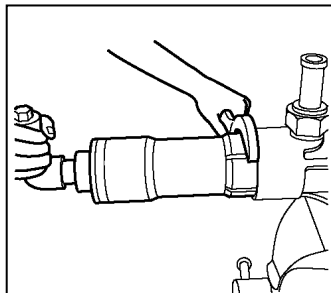

- ② Remove the cylinder (14) from the pump housing (1), Remove the check valve (8), and Remove the suction packings.

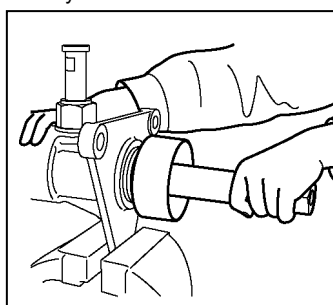
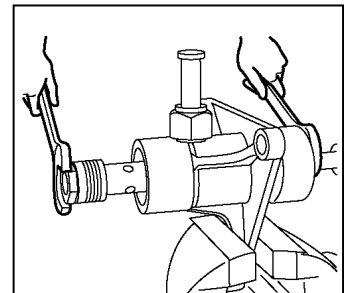

- ③ Loosen the packing retainer (2), Pull out the piston rod (6), then Remove the V-packings (23).

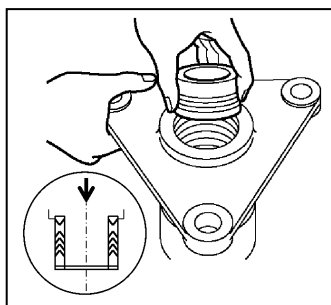

- ④ Now put on a new V-packings (23). At this point, be careful so that the direction in which the packing retainer (4) and new V-packings (23) each is installed is correct – if you install them in a wrong way, they just don't work the way they should. Reassemble in the reverse order.

- ⑤ Assembly Precautions
1. Cylinder (14) clearance should be such that it can be pushed in by hand. When it's too tight, do not use plain washers (20) at all or use only one washer. If the clearance is too tight, cylinder stroke may get sticky. If the clearance is too loose, suction failure may occur.
  2. To mount the packing retainer (2), tighten it by hand as far as you can. Then tighten it further with a spanner for another 15°~30°. If you tighten excessively, operational failure may occur. If you tighten insufficiently, oil leak may occur. Proper retightening at the end of service work helps packing to last longer.
  3. When you attach the material cylinder part to the air motor part, be sure to check that the pressure of the air route is 0MPa and the pump won't operate.

※ For part index numbers, see page 17-23.

Symptom	Cause	Remedy
<b>1. No fluid pressure</b>	① Air regulator not opened.	① Fully open.
	② Defective pressure gauge (Contrary to the meter reading, fluid pressure builds up normally.)	② Replace it with a new one.
	③ Suction valve sticky due to solidified paint left unremoved, which is accounted for by poor cleaning. post-shutdown cleaning.	③ Flush thoroughly with thinner. If hardened paint still remains after that, disassemble pump and clean.
	④ Defective air regulator	④ Take parts apart and clean the air regulator or replace with a new one.
<b>2. Pressure does not rise to working pressure</b>	① Air in fluid passage	① Pull spray gun trigger for air bubble purging through fluid circulation.
	② Insufficient fluid supply	② Replenish fluid.
	③ Worn V-packings	③ Replace V-packings following pump housing replacement procedure.
	④ V-packing installed in reversed direction	④ Clean suction filter.
	⑤ Swollen suction hose with fluid passage (I.D.) that got too small	⑤ Replace the suction hose with a new one.
<b>3. Fluid flow drops</b>	① Insufficient compressed air supply capacity	① Pull spray gun trigger for air bubble purging through fluid circulation.
	② Compressed air supply pump too small in diameter	② Use larger hose in terms of diameter.
	③ Much compressed air consumed elsewhere	③ Provide a separate pipe line.
	④ Air regulator not operating properly or setting pressure too low	④ Readjust.
	⑥ Worn air cylinder valve or pump packings	⑤ Replenish fluid.
	⑥ Worn air cylinder valve or pump packings	⑥ Replace the worn parts in accordance with the Parts Replacement Procedure.
	⑦ Nozzle or filter getting clogged with foreign materials	⑦ Flush and clean each part.
	⑧ Worn spray nozzle	⑧ If worn too fast, suspect nozzle compatibility with fluid. We have various kinds of spray nozzles for you to choose from. Please contact us to determine the spray nozzle that will best serve your purpose. Also, don't use a pressure that is higher than required: an excessive pressure will make the service life of a hose shorter.
	⑨ Material filter is clogged.	⑨ Clean the material filter.

Symptom	Cause	Remedy
<b>4. Fluttering spray and tails</b>	① ① through ③ per 3 above, apply	① Check ① through ③ per 3 above
	② Fluid viscosity too high	② Adjust viscosity to proper level
	③ Clogged or contaminated nozzle	③ Clean
<b>5. Pump does not stop when stop spraying</b>	① No fluid	① Replenish fluid
	② Leak from fluid passage	② Bring fluid pressure down to zero and retighten
	③ Worn V-packings	③ Replace V-packings with new ones.
<b>6. Air motor fails to run</b>	① Worn or damaged roller pin	① Replace following the Part Replacement Procedure
	② Damage or burrs on the sliding surfaces of cam (12), pusher holder (9) and pusher (15)	② Replace following the Part Replacement Procedure
	③ Spring (0109-027) fatigue	③ Replace following the Part Replacement Procedure
<b>7. Pump operates, but output low</b>	① Clogged suction filter	① Remove and clean.
	② Worn V-packings affecting suction performance	② Replace packings with new ones
	③ Foreign materials between valve seat and ball	③ Remove and clean

1) Always pay attention to pressure

- Don't raise output pressure more than required.
- Always lock the trigger of your gun – each time you stop spraying for a break or interruption.
- When you found leak from joint,  
Bring the pressure down,  
Drain the fluid,  
Locate the point of leakage,  
Retighten.
- Use the lowest pressure possible, when:  
Flushing the fluid circulation passage in the system,  
Circulating fluid.  
(Air pressure at about 0.1MPa)

(2) Check the appearance of the material hose.

- Is there any sharp bending along the line?
- Are hose fittings tight enough?
- No hose damage?
- No trace of any heavy object placed on the hose?
- Replace the concerned parts to new one if these abnormalities are detected.

(3) In switching and addition of the paints,

- When you change paint fluid, thoroughly flush the can with solvent so that no paint residue may be left unremoved. (Paint residue may cause the nozzle to get clogged.)
- Be sure to add the filtered paints.
- In color changing, draw the suction part out from the paint can and discharge all paints by opening the valve of gun or outlet side.  
Next, repeat the procedures of suction (It reduces cleaning solvent consumption.), circulation and discharging and then, change the color after the paint route is completely cleaned.

**(Note) The specifications and configurations of this equipment are subject to change without prior notice due to improvements being made continuously.**

# 9

## Exploded Diagram and Names of Parts

### ● Appearance

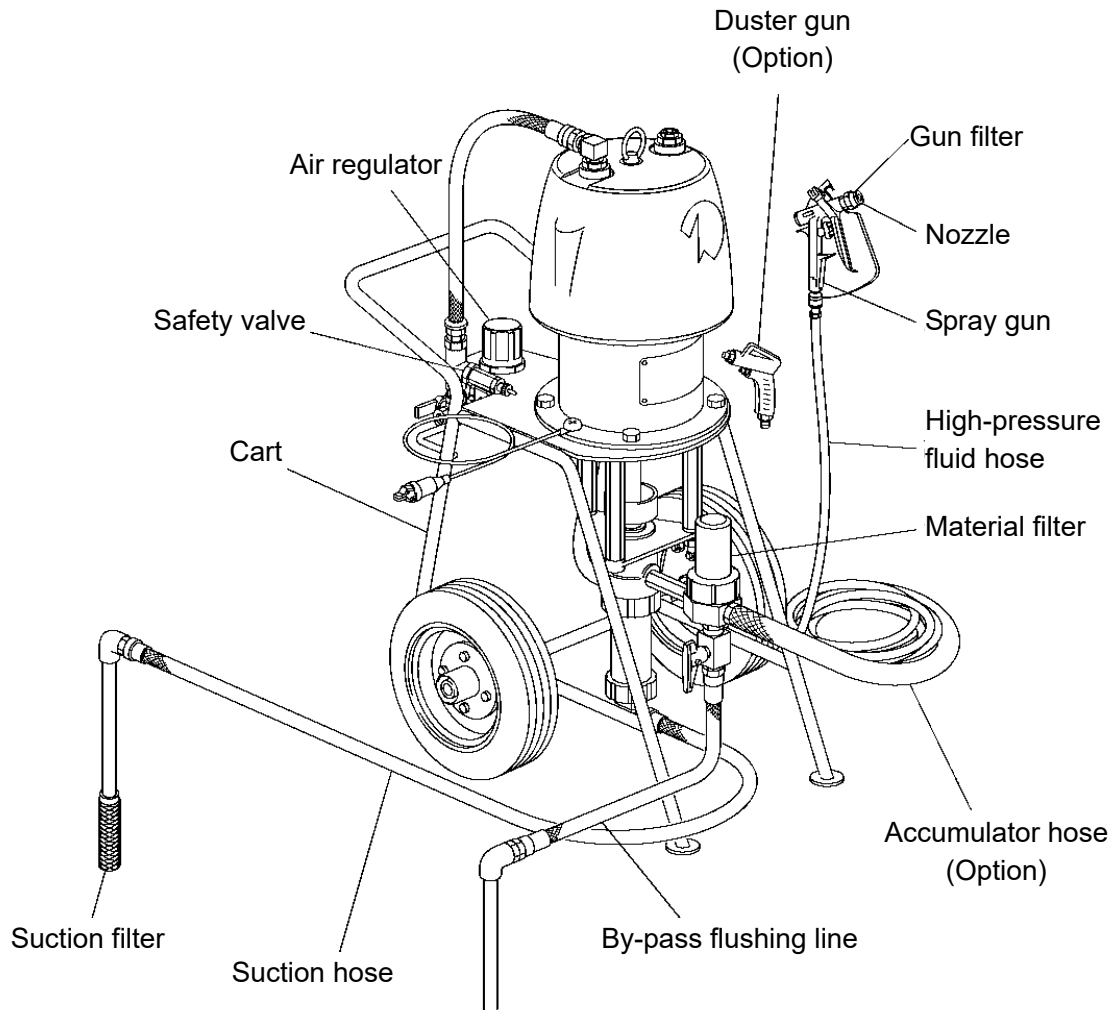

SP1854Z

40330-4

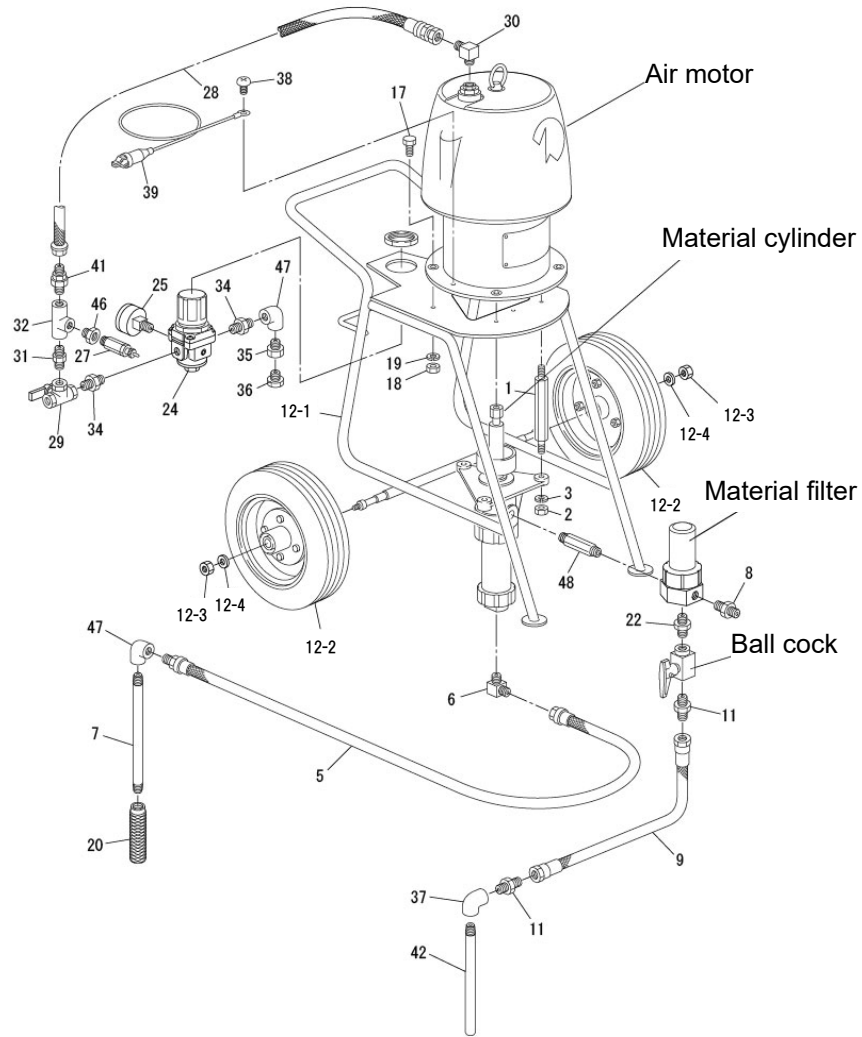

**Airless Pump SP1854Z**

No.	Part No.	Part Name	Qty	Remarks
1	4108-001	Stay	3	
2	15-12000	Hex nut	3	
3	41-52000	Spring washer	3	
5	524-1015	Suction hose	1	
6	295-2606	L-shaped nipple	1	
7	4303-002	Suction pipe	1	
8	3201-047	Fitting	1	
9	508-1010	Material hose	1	
11	3201-012	Fitting	2	
12	2068-7	Cart	1set	
12-1	2068-701	Cart frame	1	※
12-2	309-0009A	Wheel	2	※
12-3	15-11200	Hex nut	2	※
12-4	37-11200	Plain washer	2	※
17	01-11030	Hex bolt	3	
18	15-11000	Hex bolt	3	
19	41-51000	Spring washer	3	
20	0506	Cylindrical filter	1	40 mesh
22	287-2003	High-pressure nipple	1	

No.	Part No.	Part Name	Qty	Remarks
24	301-0069	Air regulator	1	
25	305-0012	Pressure gauge	1	
27	310-0006	Safety valve	1	
28	544-1006	Air hose	1	
29	325-0048	Three-way ball cock	1	
30	295-2404	L-shaped nipple	1	
31	242-1006	Barrel nipple	1	
32	205-3006	Tee	1	
34	287-2006	High-pressure nipple	2	
35	234-3007	Bushing	1	
36	234-3004	Bushing	1	
37	293-2003	High-pressure elbow	1	
38	68-10406	Screw	1	
39	40338-024	Grounding wire	1	
41	299-2604	Hose nipple	1	
42	40402-003	Drain pipe	1	
46	234-3006	Bush	1	
47	201-3006	Elbow	2	
48	3208-015	Nipple	1	

Items marked with ※ No.12-1,12-2,12-3,12-4 are accessory of No.12 cart.

SP2554Z

40329-3

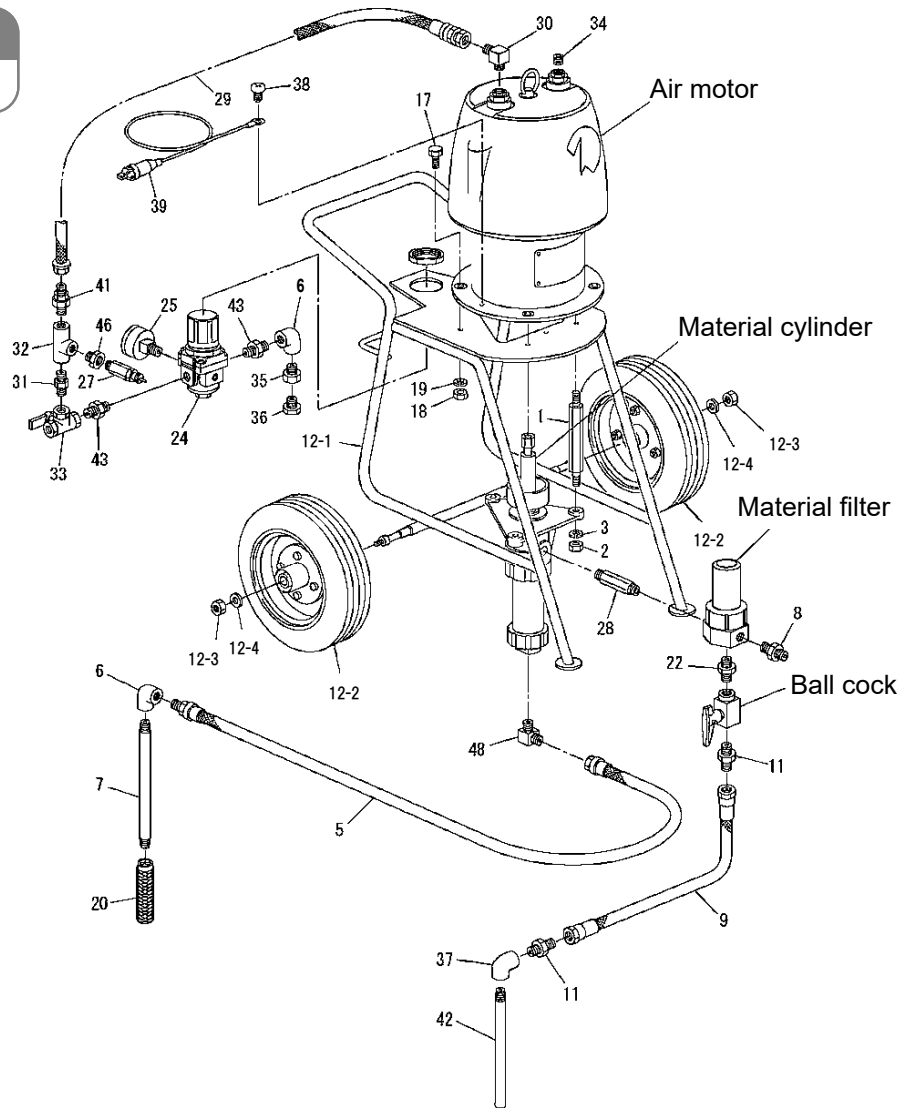

**Airless Pump SP2554Z**

No.	Part No.	Part Name	Qty	Remarks
1	4108-001	Stay	3	
2	15-12000	Hex nut	3	
3	41-52000	Spring washer	3	
5	524-1015	Suction hose	1	
6	201-3006	Elbow	2	
7	4303-002	Suction pipe	1	
8	3201-047	Fitting	1	
9	508-1010	Material hose	1	
11	3201-012	Fitting	2	
12	2068-7	Cart	1set	
12-1	2068-701	Cart frame	1	※
12-2	309-0009A	Wheel	2	※
12-3	15-11200	Hex nut	2	※
12-4	37-11200	Plain washer	2	※
17	01-11030	Hex bolt	4	
18	15-11000	Hex nut	4	
19	41-51000	Spring washer	4	
20	0506	Cylindrical filter	1	40 mesh
22	287-2003	High-pressure nipple	1	
24	301-0069	Air regulator	1	

No.	Part No.	Part Name	Qty	Remarks
25	305-0012	Pressure gauge	1	
27	310-0006	Safety valve	1	
28	3208-015	Nipple	1	
29	544-1006	Air hose	1	
30	295-2404	L-shaped nipple	1	
31	242-1006	Barrel nipple	1	
32	205-3006	Tee	1	
33	325-0048	Three-way ball cock	1	
34	244-2004	Hex. socket plug	1	
35	234-3007	Bushing	1	
36	234-3004	Bushing	1	
37	293-2003	High-pressure elbow	1	
38	68-10406	Screw	1	
39	40338-024	Grounding wire	1	
41	299-2604	Hose nipple	1	
42	40402-003	Drain pipe	1	
43	287-2006	High-pressure nipple	2	
46	234-3006	Bush	1	
48	295-2606	L-shaped nipple	1	

Items marked with ※ No.12-1,12-2,12-3,12-4 are accessory of No.12 cart.

AM1812

0103-6

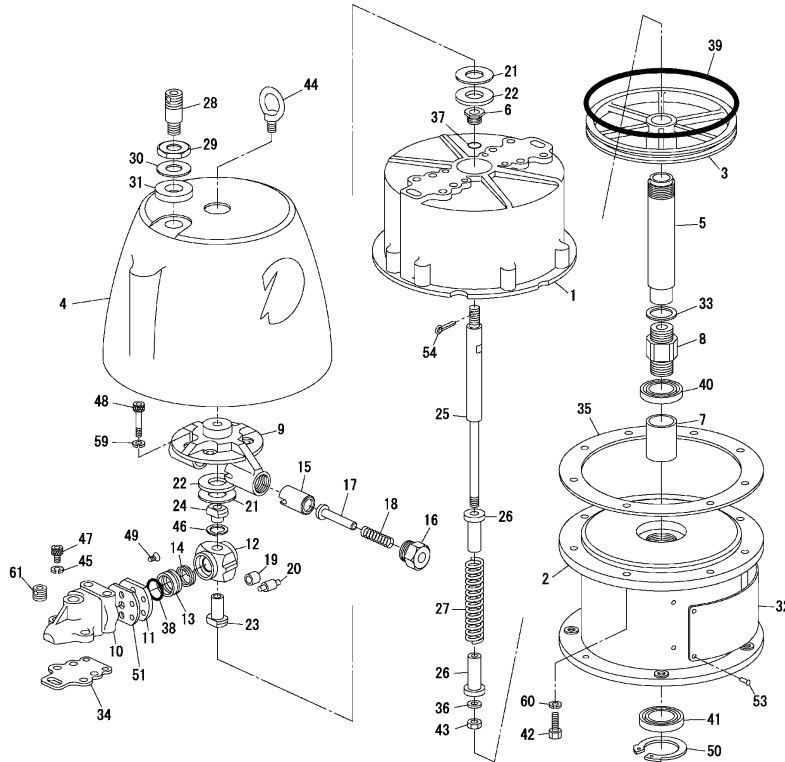

**Air motor AM1812**

No.	Part No.	Part Name	Qty	Remarks
1	0103-401	Cylinder	1	
2	0103-402A	Stand	1	
3	0103-103	Piston	1	
4	0103-404A	Cap	1	
5	0109-005	Piston rod	1	
6	0109-006	Bushing	1	
7	0109-007	Bushing	1	
8	0109-008	Adaptor	1	
9	0109-009	Pusher holder	1	
10	0103-410	Valve body	2	
11	0109-011	Plate	2	
12	0109-012	Cam	1	
13	0109-013	Valve block	2	
※14	0109-014	Spring	2	
15	0109-115	Pusher	2	
16	0109-016	Spring housing	2	
17	0109-017	Pin	2	
※18	0109-018	Spring	2	
※19	0109-119	Roller	2	
※20	0109-120	Pin	2	
21	0109-021	Ring	2	
※22	0109-022	Shock absorber	2	
23	0109-023	Spool	1	
24	0109-024	Lock nut	1	
25	0109-125	Rod	1	
26	0109-026	Spring retainer	2	
※27	0109-027	Spring	1	
28	0109-028	Nipple	1	
29	0109-029	Nut	1	
30	0109-030	Ring	1	

No.	Part No.	Part Name	Qty	Remarks
31	0109-031	Washer	1	
32	0103-633	Nameplate	1	
33	146-7022	Gasket	1	
34	147-6020	Gasket	2	
※35	146-6020	Gasket	1	
※36	0109-199	Stopper	1	
※37	101-60125	O-ring	1	
※38	101-6040	O-ring	2	
※39	101-6165	O-ring	1	
40	142-4003	Y-shaped packing	1	
41	151-0020	Oil seal	1	
42	01-11035	Hex. nut	8	
43	0109-032	Nut	1	
44	04-11600	Eye bolt	1	
45	41-51000	Spring washer	4	
46	48-51200	Spring washer	1	
47	03-51035	Hex. socket bolt	4	
48	03-512105	Hex. socket bolt	4	
49	69-10514	Screw	8	
50	56-75800	Stop ring	1	
51	147-6011	Gasket	2	
53	91-40408	Parker stud	4	
54	49-10220	Cotter pin	1	
56	0103-148	Sound proof mat	1	
57	0103-149	Sound proof mat	2	
58	0103-150	Sound proof mat	2	
59	41-51200	Spring washer	4	
60	0C-91000	Spring washer	8	
61	244-2004	Hex socket plug	1	

Items marked with ※ are the parts we recommend you to carry in stock.



MC5412Z

0272-3

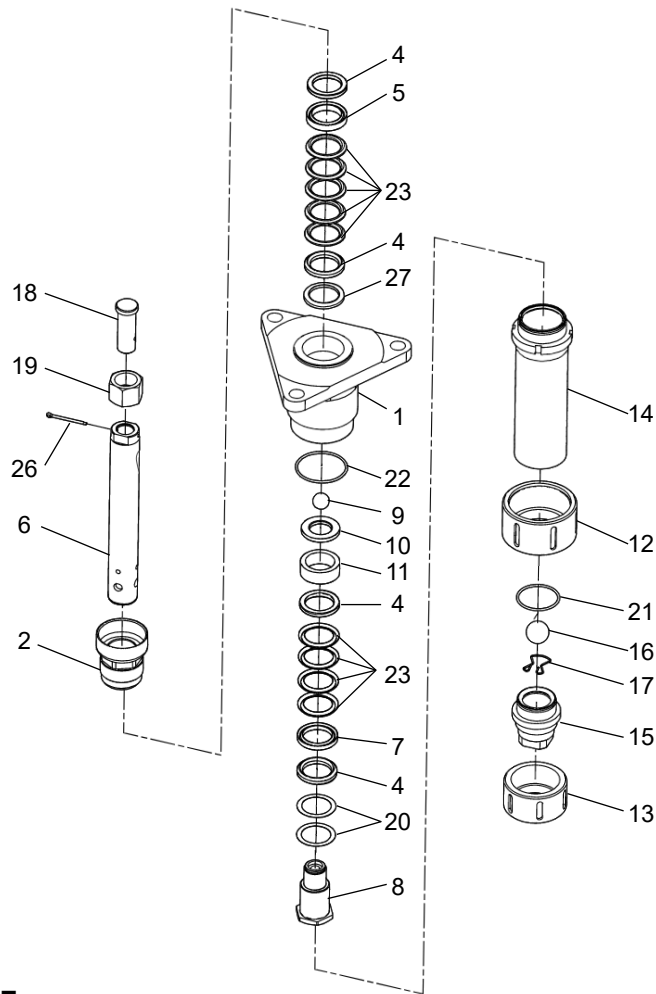

**Material cylinder MC5412Z**

No.	Part No.	Part Name	Qty	Remarks
1	0272-001A	Pump housing	1	
2	0288-002	Packing retainer (with cup)	1	
4	0275-005	Packing retainer	4	
5	0270-003	Retainer	1	
6	0272-006	Piston rod	1	
7	0272-003	Retainer	1	
8	0272-008	Check valve	1	
※9	0224-109	Valve ball	1	
10	0270-010	Ring	1	
11	0272-311	Spacer	1	
12	0253-012	Nut	1	
13	0253-013	Nut	1	

No.	Part No.	Part Name	Qty	Remarks
14	0253-014	Cylinder	1	
15	0272-015	Foot valve	1	
※16	0224-116	Valve ball	1	
17	0253-017	Ball stop	1	
18	0270-018	Stud bolt	1	
19	0270-019	Nut	1	
20	0275-011	Washer	2	
※21	102-2055	O-ring	1	
※22	102-2065	O-ring	1	
※23	V853930545	V-packing	9	
26	49-10445	Split pin	1	
27	0288-026	Ring spring	1	

Items marked with ※ are the parts we recommend you to carry in stock.

SFC506

0506

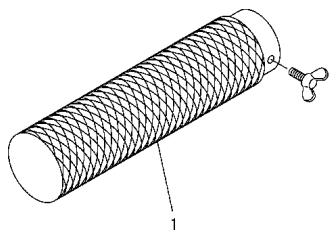

**Cylindrical filter SFC506, #40**

No.	Part No.	Part Name	Qty	Remarks
※1	0506	Cylindrical filter	1	40 mesh

Items marked with ※ are the parts we recommend you to carry in stock.

## MF100E

0424

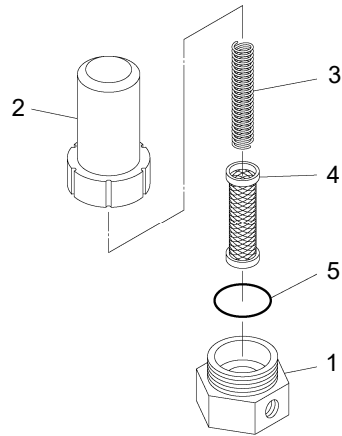

### Material filter MF100E

No.	Part No.	Part Name	Qty	Remarks
1	0424-001	Base	1	
2	0424-002	Housing	1	
3	0409-004	Spring	1	

No.	Part No.	Part Name	Qty	Remarks
※4	0414-005-04	Screen	1	40 mesh
5	102-2055	O-ring	1	

Items marked with ※ are the parts we recommend you to carry in stock.

## HPC3T

0901

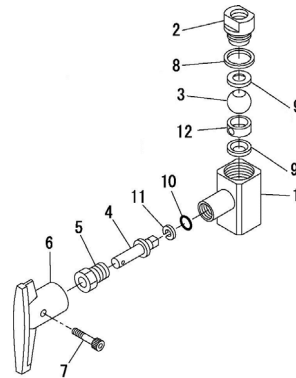

### Ball cock HPC3T

No.	Part No.	Part Name	Qty	Remarks
1	0901-201	Body	1	
2	0901-002	Seat housing	1	
※3	0901-003	Valve ball	1	
4	0901-104	Handle shaft	1	
5	0901-105	Packing retainer	1	
6	0901-006	Handle	1	

No.	Part No.	Part Name	Qty	Remarks
7	03-50422	Hex. socket bolt	1	
※8	146-2001	Gasket	1	
※9	145-2001	Ball seat	2	
※10	101-6010	O-ring	1	
※11	106-2010	Backup ring	1	
12	0901-013	Spacer	1	

Items marked with ※ are the parts we recommend you to carry in stock.

## Air combination

Option

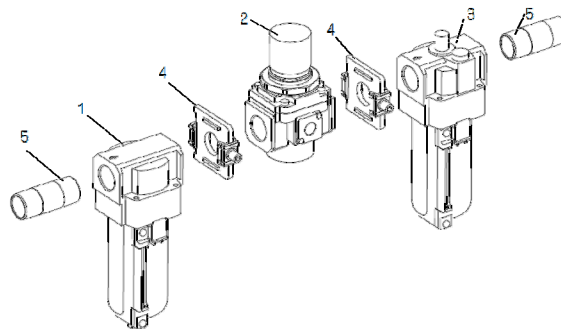

### Air combination

No.	Part No.	Part Name	Qty	Remarks
1	303-0007	Air filter	1	
2	301-0069	Air regulator	1	
3	302-0005	Lubricator (oil)	1	

No.	Part No.	Part Name	Qty	Remarks
4	341-0020	Spacer assembly	2	Packing used: 373-0021
5	6160-001-9	Nipple	2	



ASAHI SUNAC CORPORATION (the “Company”) shall provide the original purchaser (the “Purchaser”) with warranty service for a period of one (1) year from the date of purchase of the product, as follows:

- Should you find defects in design or workmanship with regard to parts, ship them back to the Company, with freight prepaid. The Company shall repair or replace the parts free of charge and reimburse the freight charges, provided that, as a result of an inspection and investigation of the parts conducted by the Company, the defects are deemed to be attributable to the factors within the Company’s responsibility.
  
- In the following cases, free after-sales service is not provided.
  1. Failure resulting from an inappropriate method of installing this equipment.
  2. Failure resulting from a use method not conforming to this instruction manual or mishandling.
  3. Failure resulting from insufficient maintenance management of this equipment and incorrect handling such as non-conformance to the procedures specified in this instruction manual.
  4. Failure resulting from unauthorized alteration or structure change of this equipment without the Company’s consent.
  5. Failure due to force majeure such as earthquake, disaster, flood disaster or lightning.
  6. Warranty for consumables worn or deteriorated even in the case where this equipment is used correctly.
  7. Repair after the machine has been used outside Japan, and shipping cost.
  8. In addition to the above, failure due to circumstances beyond our control.
  
- As for items such as parts purchased by the Company from another manufacturer, the warranty of that manufacturer shall apply.
  
- As for any parts deemed to be defective, the Company shall not be held liable for any expenses beyond the provision of repair or replacement parts free of charge.
  
- The Company shall not be held liable for any damage to the Purchaser caused by factors not attributable to the Company, such as misuse of product, etc.

【MEMO】



- 
- When a transfer of title of this equipment takes place, please ensure that this Operation and Maintenance Manual is handed over to the new owner.
  - This equipment is manufactured in compliance with the Laws and Regulations of Japan. In the rare eventuality of this equipment being used outside Japan, compliance with the safety standards of the relevant countries is of course mandatory.
- 

20th Edition: August 23, 2024

## ASAHI SUNAC CORPORATION

HEAD OFFICE  
5050, SHINDENBORA, ASAHIMAE-CHO,  
OWARIASAH, AICHI PREF. 488-0852, JAPAN  
PHONE +81-561-52-0717 FAX +81-561-54-8847

URL : [www.sunac.co.jp](http://www.sunac.co.jp)  
E-mail : [ctrd01@sunac.co.jp](mailto:ctrd01@sunac.co.jp)

Sales office



English



Chinese

20th Edition: August 23, 2024